

29 AUGUST-1 SEPTEMBER 2019
AUBURN AUCTION PARK

FALL

AUBURN

— A Labor Day Tradition —

AUCTION • CAR CORRAL • SWAP MEET



Featuring
The
Ed Meurer
Collection

90+ MOTOR CARS OFFERED
ALMOST ENTIRELY WITHOUT RESERVE.



Auctions





Lot 3073: 2005 Ford GT

29 AUGUST-1 SEPTEMBER 2019
AUBURN AUCTION PARK **FALL**
AUBURN
— A Labor Day Tradition —

EVENT INFORMATION

LOCATION

Auburn Auction Park
5536 County Road 11A
Auburn, Indiana
46706

ADMISSION

Admission to the auctions on Thursday, 29 August, Friday, 30 August, Saturday, 31 August, and Sunday, 1 September, requires the purchase of a day, event, or bidder pass.

ON-SITE TICKETS (BEGINS AUGUST 29)

- \$25 – Single Day pass
- \$50 – Event pass
- FREE – Military and First Responders with valid ID
- FREE – Children 12 and under

BIDDERS:

- \$100 – Includes admission for one bidder and one guest
- \$15 – Per additional bidder guest

VIP REGISTRATION - \$400

Contact: Jera Presley
t: +1 260 927 9797
m: +1 260 316 7740
jpresley@rmsothebys.com

AUCTION SCHEDULE

Thursday | 29 August 2019

Automobilia..... 10:00 a.m.
Cars 2:00 p.m.

Friday | 30 August 2019

Automobilia..... 10:00 a.m.
Cars 11:00 a.m.

Saturday | 31 August 2019

Automobilia..... 10:00 a.m.
Cars 11:00 a.m.

Sunday | 1 September 2019

Automobilia..... 10:00 a.m.
Cars 11:00 a.m.

Please see page 10-11 for additional event information.

GENERAL INQUIRIES AND ON-SITE CONTACT

+1 260 927 9797
info@rmsothebys.com

GOLF CART RENTALS

Golf cart rentals are available on a first-come, first-served basis and can be arranged ahead of time by contacting Dever Golf Carts at +1 859 455 9586 for pricing and information.

RV PARKING

Clients interested in RV parking at the Auburn Auction Park can contact Bonita Howe at bhowe@rmsothebys.com or +1 260 927 9797 to arrange.

EVENT RV PASS – \$150

The event RV pass includes two (2) event passes. Please note that daily camping rates are not available. AACA Members attending the Eastern Meet will receive a complimentary camping spot.

MUSEUMS/ATTRACTIONS

AUBURN CORD DUESENBERG (ACD) MUSEUM

1600 S. Wayne St., Auburn, IN 46706
+1 260 925 1444
Hours: Friday, 9:00 a.m.–5:00 p.m.;
Saturday & Sunday, 9:00 a.m.–5:00 p.m..

NATIONAL AUTOMOTIVE AND TRUCK MUSEUM (NATMUS)

1000 Gordon M. Buehrig Place, Auburn, IN 46706
+1 260 925 9100
Hours: 9:00 a.m.–5:00 p.m.

EARLY FORD V-8 MUSEUM

2181 General Doolittle Dr., Auburn, IN 46706
+1 260 927 8022
Hours: 9:00 a.m.–5:00 p.m. (closed Sunday)

As you can see, there will be no shortage of great museum experiences all located close to our meet site. Indiana has a wealth of interesting sites within an hour or so of Auburn, so you can really make this a special vacation! Go to www.dekalbcvb.org to find information on antiques, shopping, wineries, and more. Also, there are other airplane and train museums, as well as Amish tours, to see in the area.



Auctions

CLIENT SERVICE

RM Auctions has a world-renowned support team that prides itself on providing the best experience possible to our clients. If you would like to register to bid or order catalogues, or if you have any questions about logistical processes, shipping, registrations, or general inquiries, our team is here to help.

CLIENT SERVICE REPRESENTATIVES



**JERA
PRESLEY**

t: +1 260 927 9797
m: +1 260 316 7740
jpresley@rmsothebys.com



**MADLINE
BAKER**

t: +1 519 352 4575
m: +1 905 442 5426
mbaker@rmsothebys.com



**AZAR
KHOSROSHAHI**

t: +1 310 559 4575
m: +1 215 806 7818
azar@rmsothebys.com



**LYDIA
THOMPSON**

t: +1 519 352 4575
m: +1 226 919 7001
lthompson@rmsothebys.com

LEGEND

† **NO INTERNET BIDDING:** Please note that Internet bidding is not available for this lot. Interested parties that are unable to attend the sale may register to bid by telephone or place a commission bid online at rmsothebys.com.

◇ **OWNERSHIP INTEREST:** Lots with this symbol indicate that RM Sotheby's ("RMS") has an ownership interest in the lot in whole or in part.

RECOMMENDED HOTELS

La Quinta Inn & Conference Center

306 Touring Drive
Auburn, Indiana
+1 260 920 1900

Hampton Inn

1020 Smaltz Way
Auburn, Indiana
+1 260 925 1100

Holiday Inn Express

404 Touring Drive
Auburn, Indiana
+1 260 925 1900

Hampton Inn

3520 E Dupont Road
Fort Wayne, Indiana
+1 260 483 3999

BIDDER REGISTRATION

ON-SITE REGISTRATION



Those wishing to attend the sale can register to bid by visiting the Bidder Registration Desk. You will be expected to present all listed bidding requirements and pay the \$100 registration fee. Should you prefer, you may register in advance to avoid on-site queues. To do this, please visit rmsothebys.com/bid or contact Client Service at +1 260 927 9797.

TELEPHONE REGISTRATION



If you are unable to attend the sale, we offer telephone-bidding services free of charge. An RM representative will call you at the phone numbers you provided approximately three to five lots before the lot of interest comes up for sale. They will then act as your liaison to the live bidding environment and place bids on your behalf, per your instruction. To register for phone bidding, please visit rmsothebys.com/registration or contact Client Service at +1 260 927 9797.

Bidding Requirements:

- Driver's License or Passport Identification
- Credit Card
- Dealer License (if registering as a dealer)
- Bank Letter (please visit rmsothebys.com/bid for acceptable formats)
Please be advised that if you do not provide us with a Bank Letter of Guarantee, we will not accept a personal or company check, and your purchase will need to be settled by wire transfer, certified check, or cash.

We offer multiple bidding options should you choose to register, including:

ABSENTEE REGISTRATION



Alternatively, you may prefer to leave a maximum bid with us in advance of the sale, which is known as an Absentee Bid. An RM Auctions representative will then represent this bid in the live auction room, bidding up to your maximum until you have either won the lot or your bid has been surpassed. To register as an absentee bidder, please visit our website at rmsothebys.com/registration or contact Client Service at +1 260 927 9797.

INTERNET REGISTRATION



Unlike in other online auctions, you can bid in real time during the live auction. The online bidding application will launch when the auction is scheduled to begin. Clients looking to bid over the Internet are urged to register in advance, as they will be required to create an account (username and password) prior to choosing the auction for which they wish to register. Please visit rmsothebys.com/registration and click on "Internet" to create your account and register for the sale.

AUBURN AUCTION PARK VIP PACKAGE

– INCLUDES –

- COMPLIMENTARY BIDDER CREDENTIALS + 1 FREE GUEST (PICKUP AT AUCTION OFFICE)
- COMPLIMENTARY VIP PARKING PASS (MAILED TO YOUR HOME PRIOR TO AUCTION)
- VIP DECK ACCESS WITH FREE FOOD & DRINKS!
- DISCOUNT ADMISSION AT THE ACD AUTOMOBILE MUSEUM (ONLY \$8.50, REGULARLY \$12.50)
- 10% OFF AT THE ACD AUTOMOBILE MUSEUM GIFT SHOP



Ride in style

DEVER GOLF CART RENTALS

Golf cart rentals are available on a first-come, first-served basis and can be arranged ahead of time by contacting Dever Golf Carts at:

+1 859 455 9586

For pricing and information:

www.deverinc.com



– \$400 –



Contact: Jera Presley
+1 260 927 9797
jpresley@rmsothebys.com



29 AUGUST-1 SEPTEMBER 2019
AUBURN AUCTION PARK **FALL**

AUBURN

— A Labor Day Tradition —



Auctions



















WELCOME TO
AUBURN
CLASSIC CAR CAPITAL OF THE WORLD

WELCOME TO HISTORIC AUBURN, INDIANA,
THE CLASSIC CAR CAPITAL OF THE WORLD!
WE HOPE YOU ENJOY YOUR STAY!

THE FOLLOWING TRAVEL GUIDE IS INTENDED TO PROVIDE
YOU WITH HELPFUL SUGGESTIONS ON GREAT RESTAURANTS,
PLACES TO VISIT, AND FAMILY FUN ACTIVITIES!

AUBURN



- 
NOBLE HAWK GOLF LINKS
 +1 260 349 0090
 3005 NOBLE HAWK DR, KENDALLVILLE, IN 46755
- 
HAMPTON INN - AUBURN (HOST HOTEL)
 +1 774 221 0055
 1020 SMALTZ WAY, AUBURN, IN 46706
- 
DEKALB COUNTY AIRPORT (PRIVATE)
 +1 260 927 8876
 2710 CO RD 60, AUBURN, IN 46706
- 
ACD MUSEUM
 +1 260 925 1444
 1600 WAYNE ST, AUBURN, IN 46706
- 
NATMUS MUSEUM
 +1 260 925 9100
 1000 GORDON M BUEHRIG PL, AUBURN, IN 46706
- 
EARLY FORD V-8 MUSEUM
 +1 260 927 8022
 2181 GENERAL DOOLITTLE DR, AUBURN, IN 46706
- 
NCG CINEMAS
 +1 260 925 2800
 1111 SMALTZ WAY, AUBURN, IN 46706
- 
PIZZA FORUM
 +1 260 920 1111
 215 MAIN ST, AUBURN, IN 46706
- 
AUBURN CITY STEAKHOUSE
 +1 260 333 7337
 203 MAIN ST, AUBURN, IN 46706
- 
CEBOLLA'S MEXICAN GRILLE
 +1 260 927 1182
 1037 SMALTZ WAY, AUBURN, IN 46706
- 
BYLER LANE WINERY
 +1 260 920 4377
 5858 CO RD 35, AUBURN, IN 46706
- 
MAD ANTHONY'S TAPROOM
 +1 260 927 0500
 114 NORTH MAIN ST, AUBURN, IN 46706
- 
ACD FESTIVAL
 +1 260 925 3600
 DOWNTOWN AUBURN
- 
LYN-MAREE'S BOUTIQUE
 +1 260 333 0238
 209 NORTH MAIN ST, AUBURN, IN 46706
- 
SIXTEEN:THIRTEEN BOUTIQUE
 +1 260 579 3099
 102 NORTH MAIN ST, AUBURN, IN 46706

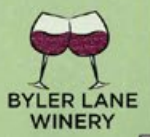

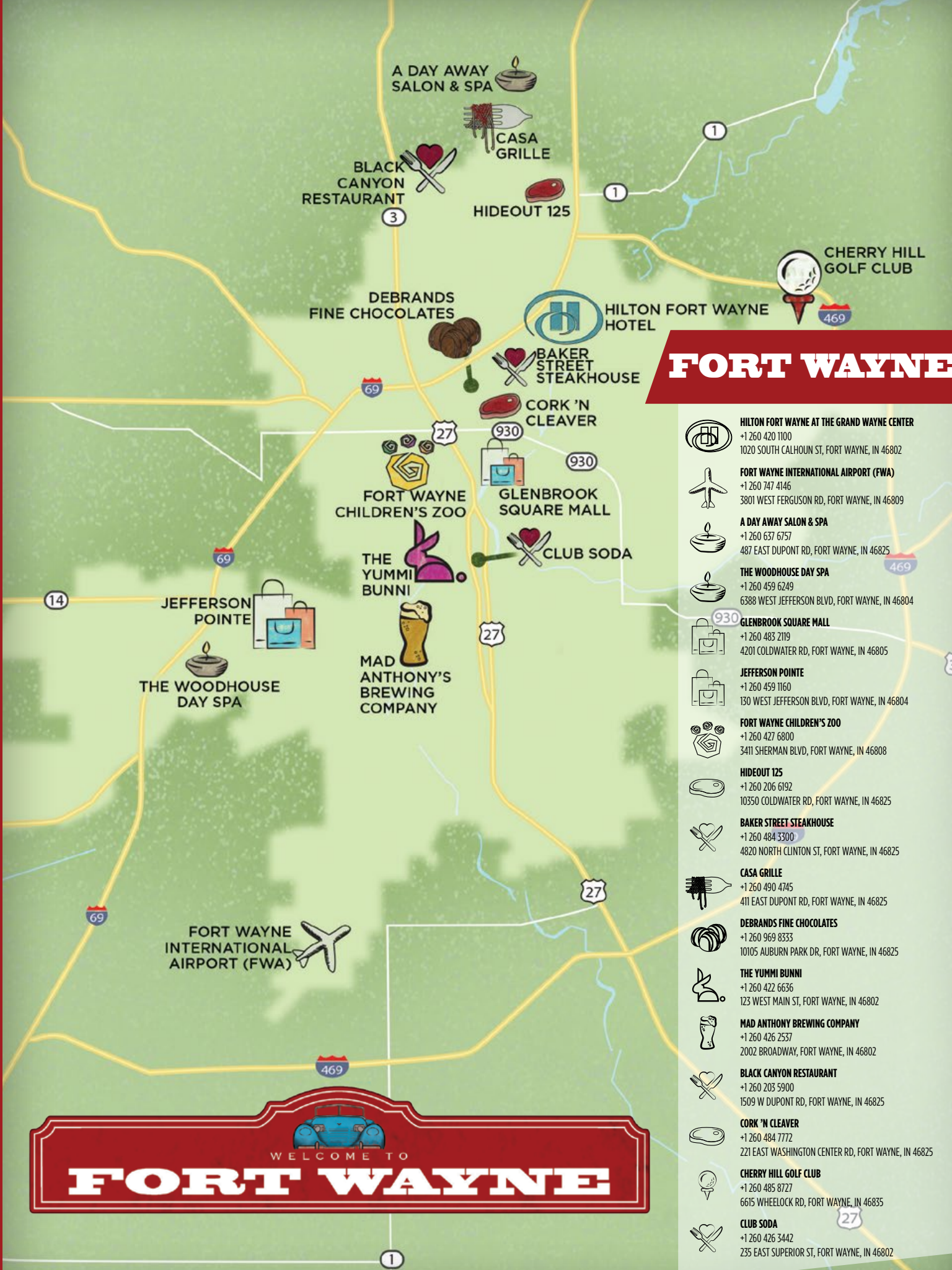

FORT WAYNE



HILTON FORT WAYNE AT THE GRAND WAYNE CENTER
 +1 260 420 1100
 1020 SOUTH CALHOUN ST, FORT WAYNE, IN 46802



FORT WAYNE INTERNATIONAL AIRPORT (FWA)
 +1 260 747 4146
 3801 WEST FERGUSON RD, FORT WAYNE, IN 46809



A DAY AWAY SALON & SPA
 +1 260 637 6757
 487 EAST DUPONT RD, FORT WAYNE, IN 46825



THE WOODHOUSE DAY SPA
 +1 260 459 6249
 6388 WEST JEFFERSON BLVD, FORT WAYNE, IN 46804



GLENBROOK SQUARE MALL
 +1 260 483 2119
 4201 COLDWATER RD, FORT WAYNE, IN 46805



JEFFERSON POINTE
 +1 260 459 1160
 130 WEST JEFFERSON BLVD, FORT WAYNE, IN 46804



FORT WAYNE CHILDREN'S ZOO
 +1 260 427 6800
 3411 SHERMAN BLVD, FORT WAYNE, IN 46808



HIDEOUT 125
 +1 260 206 6192
 10350 COLDWATER RD, FORT WAYNE, IN 46825



BAKER STREET STEAKHOUSE
 +1 260 484 3300
 4820 NORTH CLINTON ST, FORT WAYNE, IN 46825



CASA GRILLE
 +1 260 490 4745
 411 EAST DUPONT RD, FORT WAYNE, IN 46825



DEBRANDS FINE CHOCOLATES
 +1 260 969 8333
 10105 AUBURN PARK DR, FORT WAYNE, IN 46825



THE YUMMI BUNNI
 +1 260 422 6636
 123 WEST MAIN ST, FORT WAYNE, IN 46802



MAD ANTHONY BREWING COMPANY
 +1 260 426 2537
 2002 BROADWAY, FORT WAYNE, IN 46802



BLACK CANYON RESTAURANT
 +1 260 203 5900
 1509 W DUPONT RD, FORT WAYNE, IN 46825



CORK 'N CLEAVER
 +1 260 484 7772
 221 EAST WASHINGTON CENTER RD, FORT WAYNE, IN 46825



CHERRY HILL GOLF CLUB
 +1 260 485 8727
 6615 WHELOCK RD, FORT WAYNE, IN 46835



CLUB SODA
 +1 260 426 3442
 235 EAST SUPERIOR ST, FORT WAYNE, IN 46802

WELCOME TO
FORT WAYNE



HOTELS

HAMPTON INN - AUBURN (HOST HOTEL) ★★

+1 260 925 1100
1020 SMALTZ WAY, AUBURN, IN 46706
Trailer parking unavailable

POTAWATOMI INN ★★ ★

+1 260 833 1077
6 LN 100 LAKE JAMES, ANGOLA, IN 46703
Trailer parking available

HOLIDAY INN - FORT WAYNE ★★ ★

+1 260 482 3800
4111 PAUL SHAFFER DR, FORT WAYNE, IN 46825
Trailer parking available

BAYMONT BY WYNDHAM - AUBURN ★★

+1 260 920 1900
306 TOURING DR, AUBURN, IN 46706
Trailer parking available

TRU BY HILTON - FORT WAYNE ★★ ★

+1 260 444 2500
5345 DISTRIBUTION DR, FORT WAYNE, IN 46825
Trailer parking unavailable

HYATT PLACE - FORT WAYNE ★★ ★

+1 260 471 8522
111 WEST WASHINGTON CENTER RD, FORT WAYNE, IN 46825
Trailer parking available

HILTON FORT WAYNE AT GRAND WAYNE CENTER ★★ ★

+1 260 420 1100
1020 SOUTH CALHOUN ST, FORT WAYNE, IN 46802
Trailer parking available

STAYBRIDGE SUITES ★★ ★ ★

+1 260 432 2427
5925 ELLISON RD, FORT WAYNE, IN 46804
Trailer parking unavailable

HAMPTON INN - DUPONT ROAD ★★

+1 260 483 3999
3520 EAST DUPONT RD, FORT WAYNE, IN 46825
Trailer parking available

FAMILY FUN

FORT WAYNE CHILDREN'S ZOO

+1 260 427 6800
3411 SHERMAN BLVD, FORT WAYNE, IN 46808

HYSTERIUM ESCAPE

+1 260 436 0213
4410 ARDEN DR SUITE E, FORT WAYNE, IN 46804

PARKVIEW FIELD

+1 260 482 6400
1301 EWING ST, FORT WAYNE, IN 46802

NCG CINEMAS

+1 260 925 2800
1111 SMALTZ WAY, AUBURN, IN 46706

AUBURN-GARRETT DRIVE-IN

+1 260 357 3474
1014 IN-8, GARRETT, IN 46738

SKY ZONE

+1 260 483 5867
401 FERNHILL AVE, FORT WAYNE, IN 46805

CRAZY PINS

+1 260 490 2695
1414 NORTHLAND BLVD, FORT WAYNE, IN 46825

ROOM TO ESCAPE

+1 800 454 3927
3734 ALLEN AVE, FORT WAYNE, IN 46805

LASER X

+1 260 484 1350
244 FERNHILL AVE, FORT WAYNE, IN 46805

HOSPITALS

DEKALB HOSPITAL

+1 260 925 4600
1316 E 7TH ST, AUBURN, IN 46706

TRANSPORTATION

A-1 LIMOUSINE AND TAXI SERVICE

+1 260 478 9910
FORT WAYNE, IN

CLUB CAR LIMOUSINE & TROLLEY

+1 260 492 2102
FORT WAYNE, IN

LIMO SCENE

+1 260 579 5180
FORT WAYNE, IN

AA ELEGANT LIMOUSINE

+1 260 486 5059
FORT WAYNE, IN

1ST CLASS TAXI

+1 260 387 9193
FORT WAYNE, IN

ROYAL TAXI

+1 260 387 3606
FORT WAYNE, IN

ENTERPRISE RENT-A-CAR

+1 260 927 3055
AUBURN, IN

AVIS CAR RENTAL

+1 260 747 7437
FORT WAYNE, IN

MUSEUMS

ACD MUSEUM

+1 260 925 1444
1600 WAYNE ST, AUBURN, IN 46706

EARLY FORD V-8 MUSEUM

+1 260 927 8022
2181 GENERAL DOOLITTLE DR, AUBURN, IN 46706

FORT WAYNE MUSEUM OF ART

+1 260 422 6467
311 EAST MAIN ST, FORT WAYNE, IN 46802

SCIENCE CENTRAL

+1 260 424 2400
1950 NORTH CLINTON ST, FORT WAYNE, IN 46805

NATMUS MUSEUM

+1 260 925 9100
1000 GORDON M BUEHRIG PL, AUBURN, IN 46706

AIRPORTS

DEKALB COUNTY AIRPORT (PRIVATE)

+1 260 927 8876
2710 CO RD 60, AUBURN, IN 46706
**5 minutes by car to the Auburn Auction Park*

FORT WAYNE INTERNATIONAL AIRPORT (FWA)

+1 260 747 4146
3801 WEST FERGUSON RD, FORT WAYNE, IN 46809
**30 minutes by car to the Auburn Auction Park*

INDIANAPOLIS AIRPORT (IND)

+1 317 487 9594
7800 COL. H. WEIR COOK MEMORIAL DR, INDIANAPOLIS, IN 46241
**2 hours by car to the Auburn Auction Park*

GOLF COURSES

CHERRY HILL GOLF CLUB

+1 260 485 8727
6615 WHEELOCK RD, FORT WAYNE, IN 46835

NOBLE HAWK GOLF LINKS

+1 260 349 0900
3005 NOBLE HAWK DR, KENDALLVILLE, IN 46755

BRIGEWATER COURSE

+1 260 925 8184
1818 MORNINGSTAR RD, AUBURN, IN 46706



WINERIES & BREWERIES

BYLER LANE WINERY

+1 260 920 4377
5858 CO RD 35, AUBURN, IN 46706

COUNTRY HERITAGE WINERY

+1 260 637 2980
185 CO RD 68, LAOTTO, IN 46763

SATEK WINERY

+1 260 495 9463
6208 NORTH VAN GUILDER RD, FREMONT, IN 46737

MAD ANTHONY'S BREWING COMPANY

+1 260 426 2537
2002 BROADWAY, FORT WAYNE, IN 46802

CHAMPMAN'S BREWING COMPANY

+1 260 319 5495
300 INDUSTRIAL DR, ANGOLA, IN 46703

SUMMIT CITY BREWERKS

+1 260 420 0222
1501 EAST BERRY ST #106, FORT WAYNE, IN 46803

TRUBBLE BREWING

+1 260 267 6082
2725 BROADWAY, FORT WAYNE, IN 46807

THREE RIVERS DISTILLING COMPANY

+1 260 745 9355
224 EAST WALLACE ST, FORT WAYNE, IN 46803

RESTAURANTS

STEAKHOUSE

AUBURN CITY STEAKHOUSE

+1 260 333 7337
203 MAIN ST, AUBURN, IN 46706

BAKER STREET STEAKHOUSE

+1 260 484 3300
4820 NORTH CLINTON ST, FORT WAYNE, IN 46825

BLACK CANYON RESTAURANT

+1 260 203 5900
1509 W DUPONT RD, FORT WAYNE, IN 46825

CORK 'N CLEAVER

+1 260 484 7772
221 E WASHINGTON CENTER RD, FORT WAYNE, IN 46825

HIDEOUT 125

+1 260 206 6192
10350 COLDWATER RD, FORT WAYNE, IN 46825

THE TROLLEY BAR

+1 260 490 4322
2898 EAST DUPONT RD, FORT WAYNE, IN 46825

EDDIE MERLOT'S

+1 260 459 2222
1502 ILLINOIS RD SOUTH, FORT WAYNE, IN 46804

MAD ANTHONY'S TAPROOM

+1 260 927 0500
114 NORTH MAIN ST, AUBURN, IN 46706

CLUB SODA

+1 260 426 3442
235 E SUPERIOR ST, FORT WAYNE, IN 46802

ITALIAN

THE ITALIAN GRILLE

+1 260 925 9400
227 NORTH DUESENBERG DR, AUBURN, IN 46706

ZIANOS ITALIAN EATERY

+1 260 755 5643
702 EAST DUPONT RD, FORT WAYNE, IN 46825

CASA GRILLE

+1 260 490 4745
411 EAST DUPONT RD, FORT WAYNE, IN 46825

BIAGGI'S RISTORANTE ITALIANO

+1 260 459 6700
4010 W JEFFERSON BLVD, FORT WAYNE, IN 46804

PIZZA

PIZZA KING

+1 260 925 1135
1713 WAYNE ST, AUBURN, IN 46706

PIZZA FORUM

+1 260 920 1111
215 MAIN ST, AUBURN, IN 46706

BLAZE

+1 260 440 8571
401 EAST COLISEUM BLVD, FORT WAYNE, IN 46805

800 DEGREES WOOD FIRED PIZZA

+1 260 490 0111
10020 LIMA RD F, FORT WAYNE, IN 46818

B. ANTONIO'S PIZZA

+1 260 485 2400
5417 MEIJER DR, FORT WAYNE, IN 46835

BURGERS

CRICKET'S 7TH STREET BAR & GRILLE

+1 260 925 9980
120 W 7TH ST, AUBURN, IN 46706

COFFEE SHOPS

FIVE LAKES COFFEE

+1 260 220 0525
1106 W 7TH ST, AUBURN, IN 46706

MEXICAN

AGAVES

+1 260 482 4282
4405, 212 E WASHINGTON CENTER RD, FORT WAYNE, IN 46825

ARCOS RESTAURANTE MEXICANO

+1 260 203 9998
2868 EAST DUPONT RD, FORT WAYNE, IN 46825

SOMEWHERE SWEET

BOWLS FROZEN DESSERTS

+1 260 333 0299
1051 SMALTZ WAY, AUBURN, IN 46706

DEBRANDS FINE CHOCOLATES

+1 260 969 8333
10105 AUBURN PARK DR, FORT WAYNE, IN 46825

COOKIE COTTAGE

+1 260 471 6678
508 NOBLE DR, FORT WAYNE, IN 46825

COOKIE NOOK

+1 260 241 4709
204 N JACKSON ST, AUBURN, IN 46706

THE YUMMI BUNNI

+1 260 422 6636
123 WEST MAIN ST, FORT WAYNE, IN 46802

HANG 10 TROPICAL ICE

+1 260 573 3516
112 NORTH MAIN ST, AUBURN, IN 46706

THE BROWN HOUSE

+1 260 925 2466
100 EAST ENSLEY AVE, AUBURN, IN 46706

COLD STONE CREAMERY

+1 260 434 1010
4150 WEST JEFFERSON BLVD STE K5, FORT WAYNE, IN 46804

BOWLS FROZEN DESSERTS

+1 260 333 0299
1051 SMALTZ WAY, AUBURN, IN 46706

SPAS & SHOPPING

FORUM SALON & DAY SPA

+1 260 497 7732
1517 W DUPONT RD, FORT WAYNE, IN 46825

A DAY AWAY SALON & SPA

+1 260 637 6757
487 EAST DUPONT RD, FORT WAYNE, IN 46825

THE WOODHOUSE DAY SPA

+1 260 459 6249
6388 WEST JEFFERSON BLVD, FORT WAYNE, IN 46804

THE TRANQUIL TOUCH SPA

+1 260 969 7977
5812 MAPLECREST RD, FORT WAYNE, IN 46835

GLENBROOK SQUARE MALL

+1 260 483 2119
4201 COLDWATER RD, FORT WAYNE, IN 46805

JEFFERSON POINTE

+1 260 459 1160
130 WEST JEFFERSON BLVD, FORT WAYNE, IN 46804

ANTIQUES ON 5TH

+1 260 333 0586
109 E 5TH STREET, AUBURN IN 46706

FREMONT OUTLETS

+1 260 833 1516
6245 NORTH OLD 27, FREMONT, IN 46737

GLICK'S

+1 269 651 6283
1021 WEST 7TH STREET, AUBURN, IN 46706

SIXTEEN:THIRTEEN BOUTIQUE

+1 260 579 3099
102 N MAIN ST, AUBURN, IN 46706

MAINSTREAM BOUTIQUE

+1 260 432 9116
4110 W JEFFERSON BLVD, FORT WAYNE, IN 46804

LITTLE SPROUTS CHILDREN'S BOUTIQUE

+1 260 925 9534
111 NORTH MAIN ST, AUBURN, IN 46706

LYN-MAREE'S BOUTIQUE

+1 260 333 0238
209 NORTH MAIN ST, AUBURN, IN 46706

DETOUR BOUTIQUE

+1 260 319 0276
3785 EAST BELLEFONTAINE RD, HAMILTON, IN 46742

AUBURN ATRIUM MARKETPLACE

+1 260 927 1326
106 W 5TH ST, AUBURN IN 46706

LOOKING TO ADVERTISE?

HAVE A LOCAL BUSINESS YOU'D LIKE LISTED?

CALL US FOR ADVERTISING OPPORTUNITIES FOR OUR
NEXT UPCOMING SALE!

FUN FOR THE WHOLE FAMILY!

RM's Auburn Fall auction is not just an auction, it's a Labor Day weekend tradition filled with events for the entire family to enjoy.

With over 250 acres of property at the Auburn Auction Park, there are endless things to see and do, including: a FREE Kids Fun Zone; freestyle motocross shows throughout the day; Dirtfish Driving Experiences; Hagerty Ride & Drive; food vendors as far as the eye can see; a Swap Meet filled with hundreds of vendors selling just about anything; a Car Corral with over 250 cars ready to be bought!

Thursday | 29 August 2019

Swap Meet & Car Corral 9:00 a.m. – 5:00 p.m.
 Auction 10:00 a.m.
 Fun Zone 12:00 p.m. – 6:00 p.m.

Friday | 30 August 2019

Swap Meet & Car Corral 9:00 a.m. – 5:00 p.m.
 Auction 10:00 a.m.
 Fun Zone 12:00 p.m. – 6:00 p.m.
 DIRTFISH 2:00 p.m. – 6:00 p.m.
 (Show: 4:00 p.m.)

Saturday | 31 August 2019

Swap Meet & Car Corral 9:00 a.m. – 5:00 p.m.
 Auction 10:00 a.m.
 Fun Zone 10:00 a.m. – 6:00 p.m.
 Hagerty Ride & Drive 10:00 a.m. – 6:00 p.m.
 DIRTFISH 10:00 a.m. – 6:00 p.m.
 (Shows: 11:00 a.m. & 3:30 p.m.)
 Freestyle Motocross 11:30 a.m., 2:30 p.m., 4:30 p.m.
 Presented by Monster Energy

Sunday | 1 September 2019

Cars & Coffee 8:00 a.m. – 12:00 p.m.
 Fueled by Hagerty
 Swap Meet & Car Corral 9:00 a.m. – 5:00 p.m.
 Auction 10:00 a.m.
 Fun Zone 9:00 a.m. – 5:00 p.m.
 Hagerty Ride & Drive 10:00 a.m. – 5:00 p.m.
 DIRTFISH 10:00 a.m. – 2:00 p.m.
 (Show: 12:00 p.m.)

Please Note: All event times are subject to change without notice.



CARS & COFFEE FUELED BY HAGERTY

Cruise into the Auburn Auction Park for a morning of all things automotive on Sunday, 1 September, from 8:00 a.m. – 12:00 p.m. Join like-minded enthusiasts to kick tires, talk shop, and enjoy plenty of automotive eye candy, all over a cup of coffee and a donut. Beat the morning rush and enjoy the auction weekend festivities following your morning brew.

Anything with a motor is welcome, including classics, moderns, concepts, customs, motorcycles, and more, and as always, this Cars & Coffee is free to attend!



FOOD VENDORS

With so many exciting things happening at the Auburn Auction Park, guests and bidders work up quite the appetite. If you've got something you think they'll love, call us today and book your space to feed the thousands ready to indulge in more than the atmosphere.



CAR CORRAL

RM Auctions' Auburn Spring and Fall events are a haven for passionate motorheads and provide an environment in which you can sell, buy, and trade your car with confidence. If the auction block isn't the place for you, the Car Corral is the perfect opportunity to sell your car, where thousands of auto enthusiasts just like you are in attendance and ready to make a deal.



DIRTFISH DRIVING EXPERIENCES

Throughout the weekend watch and learn from the most prestigious rally-car driving school in all of North America! The Dirtfish instructors will be demonstrating their rally driving skills as well as teaching you car control, confidence, and safety behind the wheel of a rally car!



HAGERTY RIDE & DRIVE

Take a drive in a beautiful classic car through a scenic tour of Auburn, Indiana!



FREESTYLE MOTOCROSS (FMX)

Sponsored by Monster Energy Drink

Riders will be performing the best tricks and whips of the sport of FMX. The event will feature names and stars of the X-Games, Gravity Games, and Dew Tour.

- Freestyle motocross ramp-to-ramp performance: backflips, superman seat grab, nac-nac, cliff hanger, and numerous other freestyle tricks.



KIDS FUN ZONE

Visit our Kids Fun Zone, where kids can play all day for FREE!

- Bounce houses, face painting, balloon twisting, and much more!



SWAP MEET

The Auburn Auction Park Swap Meet offers everything from tools, new/used car parts, garage equipment, and gas pumps to neon signs, golf carts, clothing, jewelry, antiques, and much more! With hundreds of Swap Meet vendors at Auburn Fall, this is a great place to find exactly what you're looking for.

SEE EVENT SCHEDULE FOR ALL TIMES.

(SUBJECT TO CHANGE WITHOUT NOTICE)

TIPS FOR AUCTION PARTICIPATION

LOOK FOR THE "RIGHT" CAR

The first question anyone in the market for a collector car should have is: What will I do with the car? Will it be a Saturday-night cruiser, a daily driver, a track toy, or a concours-quality show car? It seems like a simple question, but it's the foundation for the purchase.

So, follow the adage "the right tool for the right job." A classic Corvette is likely not the best choice for your 16-year-old's daily driver. Similarly, acquiring a vintage Mustang for a weekend road race might end up costing far more than buying an example with the correct equipment already installed.

DO YOUR HOMEWORK

If you're attending an auction, review the consignments online or in a printed catalogue prior to the sale. Then, create a short list of targets and research them. Contact the auction house directly to speak with a Car Specialist; car clubs and associations can also be helpful.

DO A PERSONAL INSPECTION & TALK TO A CAR SPECIALIST

If possible, attend the auction where your dream car is being offered; it is much easier to evaluate a car in person. Bring your short list, vehicle checklist, date code book, and, if possible, an objective expert with you. It is also important to take time to meet an auction specialist and seek out their expertise and any additional background they can provide, as well as to review all the paperwork. You're making a significant purchase, so don't be afraid to crawl under the car for a thorough inspection.

Once you have narrowed down your choices, you need to be near the car when it begins its journey to the block. The vehicle will typically sit in the staging lanes for 30–60 minutes before it hits the podium. This will give you time to evaluate the car when it starts, when it's under power, while it's idling, and with repeated starts and stops. Ask the driver of the auction house to turn on the radio, work the locks, move the power top, etc. Inquire about how the clutch, steering, and brakes feel. This is your chance to ensure that everything operates properly.

PREPARE TO BID

The auction ring is an electrifying atmosphere; some thrive on the excitement, while others prefer to let a representative place their bids. If you have never participated in an auction, consider bringing a friend who can moderate your exuberance should the pressure become too intense.

Before the car rolls onto the block, move into position to watch the auction, ensure you can hear the auctioneer, and signal your bids. It's also critical to let one of the bid spotters know that you plan on bidding on a particular lot. Find a bid spotter just prior to the car rolling across the block; you can get their attention by providing an opening bid on a car that you're interested in.

Remember to hold firm on your budget and be patient. Serious buyers often wait until the bidding slows to jump in.

CHECK THE BOXES

Once the euphoria of a successful purchase subsides, it's time to return to your checklists. This step is as critical as the pre-sale work.

What paperwork, memorabilia, etc., is accompanying your vehicle? Understand what you need to collect, and if you are shipping the car, consider taking those items with you personally if you can, or place them in the trunk of the car for safekeeping.

Carefully go through the paperwork with the auction company clerk and determine when you will receive the title. Every auction house's policy varies, so make sure you are fully versed on their processes. It's also important that you triple-check the address where key documents like titles should be sent.

ESTABLISH A BUDGET

Always have a budget in mind before you arrive at the auction. It's ideal to include a 10 percent cushion, but stick to your budget. Your budget should be based on some basic solid research. Seek out resources such as the *Hagerty Price Guide*, which covers collectible and classic automobiles. Classified pages in trade magazines also provide a great resource.

Purchasing a collector car on the big stage can be a thrilling experience. For those who enjoy the excitement and frenzied pace of the collector car auction, Donnie Gould, Car Specialist, offers up the following "Seven Golden Rules" to make your auction experience a positive one.

At RM Auctions events, our partners, Hagerty and Reliable, are on-site to help you efficiently sail through your insurance and transportation paperwork.

BE REALISTIC

When you get your vehicle home, carefully look it over. If there are any issues, make a new checklist of "fixes" or upgrades, and relish the challenge. There are many resources that can help with repairs, supply parts, or provide guidance as you make the improvements.

Whether buying a collector car through a dealer, private seller, or at auction, there is always the chance that you may hit a few bumps in the road. But if you stick to the 7 Tips for Auction Participation, you'll find your treasure and the ride will be worth it.



AUCTION ROOM LAYOUT



AUCTIONEER

The auctioneer is the official conductor of the auction—the person who accepts bids and declares lots sold or not sold. The auctioneer will announce when the car has reached the point at which it may sell by telling the audience the car “will be sold.”

COMMENTATOR

The commentator’s job is to introduce each lot and give a short description of it prior to the auctioneer opening up the lot for bidding. Pay close attention, as the commentator will occasionally announce new information regarding the lot that supersedes information that may have been seen online or in the catalogue.

BID SPOTTERS

Bid spotters act as assistants to the auctioneer by watching the audience for bids that the auctioneer may not see. Should you wish to bid, get a bid spotter’s attention, and they will help relay your bid to the auctioneer.

TELEPHONE DESK

The telephone desk is where RM Sotheby’s representatives sit during the auction and relay telephone, internet, and absentee bids for clients who are unable to attend the sale but still wish to bid.

BID DISPLAY

The bid display screen will show you which lot is currently being offered, along with the current bid price (in multiple currencies). If you find it difficult to follow the auctioneer, refer to the bid display screen.

CONSIGN YOUR CAR WITH THE BEST

OUR INTERNATIONAL TEAM OF CAR SPECIALISTS IS THE LARGEST
AND MOST EXPERIENCED IN THE INDUSTRY

CORPORATE HEADQUARTERS – ONTARIO, CANADA

Gord Duff

Global Head of Auctions & Car Specialist

Blenheim, Ontario – Canada

Languages: English

+1 519 352 4575

gduff@rmsothebys.com

Thatcher Keast

Car Specialist

Blenheim, Ontario – Canada

Languages: English

+1 785 643 6459

tkeast@rmsothebys.com

Pete Fisher

Car Specialist

Blenheim, Ontario – Canada

Languages: English

+1 519 784 9300

pfisher@rmsothebys.com

Jake O’Gorman

Car Specialist

Blenheim, Ontario – Canada

Languages: English

+1 316 217 3810

jo’gorman@rmsothebys.com

Mike Fairbairn

Car Specialist

Blenheim, Ontario – Canada

Languages: English

+1 519 352 4575

mfairbairn@rmsothebys.com

EAST COAST – UNITED STATES

Donnie Gould

Car Specialist

Stuart, Florida – United States

Languages: English

+1 954 647 0779

dgoald@rmsothebys.com

Ken Wallace

Car Specialist

Washington, New Jersey – United States

Languages: English

+1 734 368 1967

kwallace@rmsothebys.com

Barney Ruprecht

Car Specialist

New York, New York – United States

Languages: English

+1 203 912 7168

bruprecht@rmsothebys.com

Zach Oller

Car Specialist

Stuart, Florida – United States

Languages: English

+1 316 217 2961

zoller@rmsothebys.com

MIDWEST/SOUTHERN – UNITED STATES

Matt Traylor

Car Specialist

Auburn, Indiana – United States

Languages: English

+1 260 494 7545

mtraylor@rmsothebys.com

Roger Willbanks

Car Specialist

Louisville, Colorado – United States

Languages: English

+1 303 918 0079

rwillbanks@rmsothebys.com

Ramsey Potts

Car Specialist

Savannah, Georgia – United States

Languages: English

+1 912 508 4096

rpotts@rmsothebys.com

WEST COAST – UNITED STATES

Alexander Weaver

Car Specialist

Los Angeles, California – United States

Languages: English, German

+1 864 313 6844

aweaver@rmsothebys.com

Evan Shone

Car Specialist

San Francisco, California – United States

Languages: English

+1 415 816 3826

eshone@rmsothebys.com

Matt Malamut

Car Specialist

Los Angeles, California – United States

Languages: English

+1 805 231 6410

mmalamut@rmsothebys.com

David Swig

Car Specialist

San Francisco, California – United States

Languages: English

+1 415 302 2247

dswig@rmsothebys.com

Shelby Myers

Global Head of Private Sales & Car Specialist

Los Angeles, California – United States

Languages: English

+1 310 559 4575

smyers@rmsothebys.com

MEMORABILIA SPECIALISTS – UNITED STATES

Kurt Forry

Memorabilia Specialist

San Francisco, California – United States

Languages: English

+1 717 623 1638

kforry@rmsothebys.com

Dan Matthews

Memorabilia Specialist

Auburn, Indiana – United States

Languages: English

+1 217 259 7059

dmatthews@rmsothebys.com



Auctions

THE LARGEST, MOST EXPERIENCED, KNOWLEDGEABLE, & GLOBAL TEAM IN THE INDUSTRY

The RM Sotheby's team of over 25 Car Specialists represents the largest and most diverse group of car experts in the industry. Collectively, our Car Specialists bring exceptional knowledge, market insight, and experience to advise both sellers and buyers of motor cars. Our specialists are true enthusiasts—respected

vintage racing drivers, senior auction industry leaders, and automotive historians—who hold relationships with the world's leading collectors. We have a highly collaborative culture where our Car Specialists work together as a team and leverage their respective areas of expertise.



10 GLOBAL OFFICES

*New York City, New York
Culver City, California
London, United Kingdom
Munich, Germany
Tilburg, Netherlands*

*Auburn, Indiana
Stuart, Florida
Chatham, Ontario
Paris, France
Milan, Italy*

8 LANGUAGES SPOKEN

*English
French
Italian
German*

*Dutch
Spanish
Japanese
Korean*

Memorabilia and Sign Rating System and Glossary (where provided)

SIGN RATING

- 9.5+** **Mint condition.** No perceptible imperfections (very rarely will any sign be rated a 10).
- 9 – 9.4** **Excellent condition.** The sign may have a minor factory flaw or very limited damage. Any such damage would not be in the image field. The sign also has excellent color, gloss, or shine.
- 8.5 – 8.9** **Very good condition.** Exhibits only minor damage, small chips, or minor wear and scratches, and has good color, gloss, or shine. If the sign is painted, it may have minor creasing along a corner or near the edge, but not in the image field.
- 8 – 8.4** **Good condition.** Only some damage, and the chips may be larger in size or in an important visual area. It will still have good color, gloss, or shine.
- 7.5 – 7.9** **Fair condition.** Significant damage, including larger and more prevalent chips, heavier wear, or creases in the field. The color, gloss, or shine may also be faded.
- 6 – 7.4** **Poor condition.** Significant damage, including creases in the field or in other important areas, as well as deep scratches and corrosion. The sign may have no gloss or shine and have faded color.
- 0 – 5** **Very poor condition.** Heavy damage, corrosion, and loss of image. A “0” rating would imply that there is no discernable image.

Please note that The Authentication Company, LLC (“TAC”) is an independent company working in association with RM Sotheby’s; any abbreviations, terms, or rating systems are strictly for informational purposes and are subject to change. RMS does not represent or warrant any ratings or references made to TAC. No information provided by TAC overrides the RM Sotheby’s Conditions of Business. RM Sotheby’s strongly recommends that Bidders perform their own inspections and due diligence on lot(s) for sale.

POST-PURCHASE DISCLAIMER

Please note all the lot descriptions in this auction catalogue rely on information provided to RM Sotheby’s by external sources including but not limited to consignors, third-party historians, and experts. Please note the bidder is responsible for any and all due diligence including but not limited to inspections and verification of the condition, authenticity, completeness, statements made in reference to, and any and all other matters regarding any motor car or any other lots offered in an RM sale.

As such, under no circumstances will RM Sotheby’s be liable for any claim made by the buyer more than 20 business days from the date of the sale. The complete and overriding Conditions of Business, which the bidder is bound by, are found at the back of this catalogue and online at rmsothebys.com.

SIGN GLOSSARY

- SST:** Single-sided tin/metal painted sign. The design is featured on one side of the sign. Tin signs are usually made of a lighter-gauge material and are easier to damage than porcelain signs.
- DST:** Double-sided tin/metal painted sign. The design is featured on both sides of the sign. While the image is usually the same on each side, they may differ. Tin signs are usually made of a lighter-gauge material and are easier to damage than porcelain signs.
- SSP:** Single-sided metal porcelain (enamel) sign. The design is featured on one side of the sign. Porcelain signs are painted in enamel and then fired, allowing the enamel to adhere to the metal. These signs are usually a heavier gauge than tin signs and are more durable.
- DSP:** Double-sided metal porcelain (enamel) sign. The design is featured on both sides of the sign. Porcelain signs are painted in enamel and then fired, allowing the enamel to adhere to the metal. These signs are usually a heavier gauge than tin signs and are more durable.
- PPP:** Porcelain (enamel) pump plate metal sign. These signs are usually smaller in size and were originally attached to gas pumps advertising the type of gasoline they dispensed. Almost all pump plates are single-sided as they were directly affixed to a gas pump.

Flange: A flange sign has a 90-degree angle along one side that allows it to be displayed perpendicular to a wall and making both sides visible. Flange signs can be found in either tin or porcelain.

Rolled Edge: One or more edges have been folded/rolled over with a ¼-inch or more lip. With American-made signs, this generally means that it was part of a larger sign or display. If all sides are rolled, it is more likely a foreign-made sign.

Convex Sign: A convex sign is arched in the middle. More often these signs are foreign-made.

Field: Generally, this is where the logo, slogan, or any other design elements are found.

Gloss: This is used to describe a porcelain enamel sign. A sign with excellent gloss has the appearance of being wet.

Shine: This is usually used to describe a painted sign and refers to the luster the sign has.

Color: This refers to the colorful design the sign had when it was new, including the original brightness and hue.



#RMAuburn



@auburnauctionpark



/rmsothebys



@rmsothebys



/rmauctionsinc

SHARE YOUR AUBURN EXPERIENCE
FOR THE CHANCE TO BE FEATURED
ON OUR JUMBOTRON



29 AUGUST-1 SEPTEMBER 2019
AUBURN AUCTION PARK

FALL

AUBURN

AUCTION • CAR CORRAL • SWAP MEET

Thursday		29 August 2019		10:00 a.m.	Automobilia		2:00 p.m.	Cars
Friday		30 August 2019		10:00 a.m.	Automobilia		11:00 a.m.	Cars
Saturday		31 August 2019		10:00 a.m.	Automobilia		11:00 a.m.	Cars
Sunday		1 September 2019		10:00 a.m.	Automobilia		11:00 a.m.	Cars



5001

New Mexico U.S. Route 66 Shield Tin Sign
\$500 - \$1,000 OFFERED WITHOUT RESERVE



5002

Oklahoma U.S. Route 66 Shield Tin Sign
\$500 - \$1,000 OFFERED WITHOUT RESERVE



5003

Virginia U.S. Route 1 Shield Tin Sign
\$400 - \$700 OFFERED WITHOUT RESERVE



5004

Florida U.S. Route 1 Shield Tin Sign
\$400 - \$700 OFFERED WITHOUT RESERVE



5005

Maine U.S. Route 1 Shield Tin Sign
\$400 - \$700 OFFERED WITHOUT RESERVE



5006

California U.S. Route 395 Shield Tin Sign
\$400 - \$700 OFFERED WITHOUT RESERVE



5007

Colorado U.S. Route 40 Shield Tin Sign
\$400 - \$700 OFFERED WITHOUT RESERVE



5008

Nevada U.S. Route 50 Shield Tin Sign
\$300 - \$500 OFFERED WITHOUT RESERVE



5009

Indiana U.S. Route 20 Shield Tin Sign
\$400 - \$700 OFFERED WITHOUT RESERVE



5010

New York U.S. Route 20 Shield Tin Sign
\$400 - \$700 OFFERED WITHOUT RESERVE



5011

Illinois 'Generic' Shield Tin Sign
\$400 - \$700 OFFERED WITHOUT RESERVE



5012

Tennessee U.S. Route 41 Shield Tin Sign
\$400 - \$700 OFFERED WITHOUT RESERVE



5013

Michigan U.S. Route 41 Shield Tin Sign
\$400 - \$700 OFFERED WITHOUT RESERVE



5014

Pennsylvania U.S. Route 322 Shield Tin Sign
\$400 - \$700 OFFERED WITHOUT RESERVE



5015

South Carolina U.S. Route 521 Shield Tin Sign
\$400 - \$700 OFFERED WITHOUT RESERVE



5016

Georgia U.S. Route 23 Shield Tin Sign
\$400 - \$700 OFFERED WITHOUT RESERVE



5017

North Carolina U.S. Route 64 Shield Tin Sign
\$400 - \$700 OFFERED WITHOUT RESERVE



5018

Oklahoma U.S. Route 81 Shield Tin Sign
\$400 - \$700 OFFERED WITHOUT RESERVE



5019

Nebraska U.S. Route 183 Shield Tin Sign
\$300 - \$500 OFFERED WITHOUT RESERVE



5020

Minnesota U.S. Route 12 Shield Tin Sign
\$400 - \$700 OFFERED WITHOUT RESERVE



5021
Arkansas U.S. Route 65 Shield Tin Sign
\$300 - \$500 OFFERED WITHOUT RESERVE



5022
Washington U.S. Route 97 Shield Tin Sign
\$300 - \$500 OFFERED WITHOUT RESERVE



5023
Arizona U.S. Route 180 Shield Tin Sign
\$300 - \$500 OFFERED WITHOUT RESERVE



5024
Wyoming U.S. Route 287 Shield Tin Sign
\$400 - \$700 OFFERED WITHOUT RESERVE



5025
Utah U.S. Route 89 Shield Tin Sign
\$300 - \$500 OFFERED WITHOUT RESERVE



5026
New Mexico U.S. Route 54 Shield Tin Sign
\$400 - \$700 OFFERED WITHOUT RESERVE



5027
Iowa U.S. Route 61 Shield Repainted Tin Sign
\$300 - \$500 OFFERED WITHOUT RESERVE



5028
Alabama U.S. Route 11 Shield Repainted Tin Sign
\$300 - \$500 OFFERED WITHOUT RESERVE



5029
Kentucky U.S. Route 27 Shield Repainted Tin Sign
\$300 - \$500 OFFERED WITHOUT RESERVE



5030
Texas U.S. Route 80 Shield Repainted Tin Sign
\$300 - \$500 OFFERED WITHOUT RESERVE



5031
Goodrich Silvertowns with Tire and Red Tube Porcelain Sign
\$1,500 - \$3,000 OFFERED WITHOUT RESERVE



5032
Firestone Tires "Most Miles per Dollar" Porcelain Sign
\$1,000 - \$2,000 OFFERED WITHOUT RESERVE



5033
GMC "Trucks Sales & Service" Porcelain Sign
\$1,500 - \$3,000 OFFERED WITHOUT RESERVE



5034
National Automobile Club "Touring Information Agent" Porcelain Sign
\$400 - \$700 OFFERED WITHOUT RESERVE



5035
Texaco "White T" "Diesel Chief L" Sign, Red
\$300 - \$500 OFFERED WITHOUT RESERVE



5036
Texaco "White T" "Fire-Chief Gasoline" Sign
\$200 - \$400 OFFERED WITHOUT RESERVE



5037
Texaco "White T" "Sky Chief Gasoline" Tin Sign
\$300 - \$500 OFFERED WITHOUT RESERVE



5038
Texaco "White T" Star Logo Small Porcelain Sign
\$300 - \$500 OFFERED WITHOUT RESERVE



5039
Texaco "White T" Star Logo Small Porcelain Sign
\$300 - \$500 OFFERED WITHOUT RESERVE



5040
Texaco "White T" Star Logo Truck Door Porcelain Diecut Sign
\$400 - \$700 OFFERED WITHOUT RESERVE



5041
 Texaco "White T" Star Logo Truck Door Porcelain Diecut Sign
 \$300 - \$500 OFFERED WITHOUT RESERVE



5042
 Texaco "White T" Star Logo Truck Door Porcelain Diecut Sign
 \$400 - \$700 OFFERED WITHOUT RESERVE



5043
 Texaco "White T" Star Logo Truck Door Porcelain Diecut Sign
 \$300 - \$500 OFFERED WITHOUT RESERVE



5044
 Two Texaco Truck Door Porcelain Signs
 \$300 - \$500 OFFERED WITHOUT RESERVE



5045
 Ten Florida Cast Aluminum License Plate Attachments
 \$300 - \$500 OFFERED WITHOUT RESERVE



5046
 Ten Florida Cast Aluminum License Plate Attachments
 \$300 - \$500 OFFERED WITHOUT RESERVE



5047
 Ten Cast Aluminum License Plate Attachments
 \$300 - \$500 OFFERED WITHOUT RESERVE



5048
 Ten Cast Aluminum License Plate Attachments
 \$300 - \$500 OFFERED WITHOUT RESERVE



5049
 Ten Cast Aluminum License Plate Attachments
 \$300 - \$500 OFFERED WITHOUT RESERVE



5050
 Ten Cast Aluminum License Plate Attachments
 \$300 - \$500 OFFERED WITHOUT RESERVE



5051
 Ten Cast Aluminum License Plate Attachments
 \$300 - \$500 OFFERED WITHOUT RESERVE



5052
 Over 20 Cast Aluminum License Plate Attachments
 \$300 - \$500 OFFERED WITHOUT RESERVE



5053
 New Hampshire and Westinghouse Porcelain License Plate Attachments
 \$200 - \$400 OFFERED WITHOUT RESERVE



5054
 Four Petroliana License Plate Attachments
 \$200 - \$400 OFFERED WITHOUT RESERVE



5056
 Nine License Plate Attachments
 \$200 - \$400 OFFERED WITHOUT RESERVE



5057
 Ten License Plate Attachments
 \$200 - \$400 OFFERED WITHOUT RESERVE



5059
 Over Ten Enamel License Plate Attachments and Radiator Badges
 \$200 - \$400 OFFERED WITHOUT RESERVE



5060
 Over 15 License Plate Attachments
 \$200 - \$400 OFFERED WITHOUT RESERVE



5062
 "Fram" Filters Pin-Up Girl Metal Sign
 \$400 - \$600 OFFERED WITHOUT RESERVE



5063
 "Dunlop" Tires Pin-up Girl Metal Sign
 \$400 - \$600 OFFERED WITHOUT RESERVE



5064
 "Shell-Penn Motor Oil 100% Pennsylvania" Metal Sign
 \$600 - \$900 OFFERED WITHOUT RESERVE



5065
 "Guide Headlamp Tester" Metal Sign
 \$150 - \$300 OFFERED WITHOUT RESERVE



5066
 "Sachs Moped-Service" with Hand Holding Engine Graphic Porcelain Sign
 \$400 - \$700 OFFERED WITHOUT RESERVE



5067
 Dunlop "Quality Costs No More" Metal Sign
 \$200 - \$400 OFFERED WITHOUT RESERVE



5068
 "Erica-Fahrräder" Cycles with Lady and Bike Graphics Metal Sign
 \$400 - \$700 OFFERED WITHOUT RESERVE



5069
 "Jenny Aero Solvenized" Gas with Plane Porcelain Sign
 \$5,000 - \$7,000 OFFERED WITHOUT RESERVE



5070
 "Jenny Solvenized Hy-Power" Gas with Factory Porcelain Sign
 \$4,000 - \$6,000 OFFERED WITHOUT RESERVE



5071
 "Smith-O-Lene Aviation Brand Gasoline" with DC-3 Porcelain Sign
 \$4,000 - \$6,000 OFFERED WITHOUT RESERVE



5072
 "Sinclair Pennsylvania Motor Oil" with Black Dinosaur Porcelain Sign
 \$3,000 - \$4,000 OFFERED WITHOUT RESERVE



5073
 Texaco "Easy Pour Can" with Hand Porcelain Sign
 \$4,000 - \$6,000 OFFERED WITHOUT RESERVE



5074
 "Super-Shell Gasoline" Porcelain Sign
 \$2,500 - \$3,500 OFFERED WITHOUT RESERVE



5075
 "Shell Premium Gasoline" Porcelain Sign
 \$2,500 - \$3,500 OFFERED WITHOUT RESERVE



5076
 "Green Streak Gasoline A Shell Product" Porcelain Sign
 \$3,000 - \$4,000 OFFERED WITHOUT RESERVE

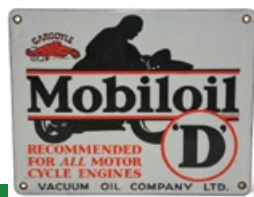

5077
 Gargoyle "Mobiloil D" with Motorcycle Porcelain Sign
 \$1,250 - \$2,000 OFFERED WITHOUT RESERVE



5078
 Gargoyle "Mobiloil BB" Can Shaped Porcelain Sign
 \$1,500 - \$2,500 OFFERED WITHOUT RESERVE



5079
 "Gargoyle Mobiloil" Porcelain Oval Globe Sign for Oil Cabinets
 \$750 - \$1,500 OFFERED WITHOUT RESERVE



5080
 Shell Car Door Porcelain Sign
 \$1,000 - \$2,000 OFFERED WITHOUT RESERVE



5081
 "Shell Aviation Service" Porcelain Sign
 \$1,500 - \$2,500 OFFERED WITHOUT RESERVE



5082
 "Gargoyle Mobiloil AF" Porcelain Sign
 \$500 - \$800 OFFERED WITHOUT RESERVE



5083
 "Gargoyle Mobiloil A" Porcelain Sign
 \$500 - \$800 OFFERED WITHOUT RESERVE



5084
 "Gargoyle Mobiloil Arctic" Porcelain Sign
 \$500 - \$800 OFFERED WITHOUT RESERVE



5085
 "Gargoyle Mobiloil BB" Porcelain Sign
 \$500 - \$800 OFFERED WITHOUT RESERVE



5086
 Sinclair Oils with Strips Small Porcelain Sign
 \$500 - \$800 OFFERED WITHOUT RESERVE



5087
 "Sunray D-X Petroleum Products" Porcelain Sign
 \$1,250 - \$2,000 OFFERED WITHOUT RESERVE



5088
 'Flying A' Logo Flat Porcelain Sign
 \$750 - \$1,500 OFFERED WITHOUT RESERVE



5089
 Tydol Ethyl with Flying A Logo Porcelain Sign
 \$500 - \$800 OFFERED WITHOUT RESERVE



5090
 Flying A Gasoline Porcelain Sign
 \$400 - \$700 OFFERED WITHOUT RESERVE



5091
 Tydol Flying A Porcelain Sign
 \$400 - \$600 OFFERED WITHOUT RESERVE



5092
 Sinclair Opaline with Strips
 Logo Porcelain Sign
 \$1,250 - \$2,000 OFFERED WITHOUT RESERVE



5093
 Shell Gasoline Porcelain Sign
 \$1,500 - \$2,000 OFFERED WITHOUT RESERVE



5094
 Golden Shell Motor Oil Small Porcelain Sign
 \$1,000 - \$1,500 OFFERED WITHOUT RESERVE



5095
 "Shell Lubrication The Modern Upkeep Service" Small Porcelain Sign
 \$1,000 - \$1,750 OFFERED WITHOUT RESERVE



5096
 "AIR" 'Shell' Porcelain Sign
 \$750 - \$1,500 OFFERED WITHOUT RESERVE



5097
 'Union' "No Smoking Stop Your Motor"
 with Speedy Porcelain Sign
 \$600 - \$900 OFFERED WITHOUT RESERVE



5098
 "Mobilgas Marine" with
 Pegasus Porcelain Sign
 \$2,500 - \$3,500 OFFERED WITHOUT RESERVE



5099
 "Mobiloil Aero" with Pegasus Porcelain Sign
 \$2,000 - \$3,000 OFFERED WITHOUT RESERVE



5100
 "Mobilgas Aircraft" with
 Pegasus Porcelain Sign
 \$1,500 - \$2,250 OFFERED WITHOUT RESERVE



5101
 'Mobil' "Metro" with Pegasus Porcelain Sign
 \$1,000 - \$2,000 OFFERED WITHOUT RESERVE



5102
 "Mobilfuel Diesel" with
 Pegasus Porcelain Sign
 \$500 - \$900 OFFERED WITHOUT RESERVE



5103
 "Mobilgas Special Gasoline" with
 Drop-Leg Logo Porcelain Sign
 \$400 - \$600 OFFERED WITHOUT RESERVE



5104
"Mobilgas Special" with Pegasus Small Porcelain Sign
 \$750 - \$1,500 OFFERED WITHOUT RESERVE



5105
Mobiloil with Pegasus Porcelain Sign
 \$400 - \$700 OFFERED WITHOUT RESERVE



5106
'Mobil' Pegasus Porcelain Sign
 \$400 - \$800 OFFERED WITHOUT RESERVE



5107
Mobilheat with Pegasus Porcelain Sign
 \$3,000 - \$5,000 OFFERED WITHOUT RESERVE



5108
Shell Gasoline Shell Motor Oil Porcelain Thermometer
 \$1,500 - \$2,500 OFFERED WITHOUT RESERVE



5109
Mobiloil with Pegasus Porcelain Thermometer
 \$1,000 - \$1,750 OFFERED WITHOUT RESERVE



5110
"Sinclair Opaline Motor Oils" with Strips Porcelain Sign
 \$1,500 - \$2,500 OFFERED WITHOUT RESERVE



5111
Mobil Battery Care Poster with Six Volt Battery
 \$200 - \$400 OFFERED WITHOUT RESERVE



5112
1924 Buick GMC Calendar from Petty Automobile CO. Red Oak, Iowa
 \$200 - \$400 OFFERED WITHOUT RESERVE



5113
1924 Hudson and Essex Calendar from Guy L. Smith Farnam St., Omaha
 \$200 - \$400 OFFERED WITHOUT RESERVE



5116
"School Chicago Motor Club" Diamond Sign
 \$200 - \$400 OFFERED WITHOUT RESERVE



5117
Early Wooden Detour Arrow with Glass Cat Eyes Sign
 \$400 - \$800 OFFERED WITHOUT RESERVE



5118
Indian Gas with Red Dot Logo Large Porcelain Sign
 \$3,000 - \$4,000 OFFERED WITHOUT RESERVE



5119
Dad's "The Old Fashioned Root Beer" Metal Sign
 \$600 - \$1,000 OFFERED WITHOUT RESERVE



5120
Orange-Crush "The New Flavor Guarding Bottle" Metal Sign
 \$750 - \$1,000 OFFERED WITHOUT RESERVE



5121
Pepsi-Cola "Refreshing-Satisfying" Bottle Shaped Sign
 \$600 - \$900 OFFERED WITHOUT RESERVE



5122
Drink Coca-Cola with Bottle Metal Sign
 \$600 - \$900 OFFERED WITHOUT RESERVE



5123
Drink Coca-Cola "Hello Refreshment" with Woman in Swimsuit Poster
 \$600 - \$900 OFFERED WITHOUT RESERVE



5124
Dr. Pepper Poster with Madelon Mason
 \$600 - \$900 OFFERED WITHOUT RESERVE



5125
Viscoyal "We Sell Coal Oil" Porcelain Sign
 \$600 - \$900 OFFERED WITHOUT RESERVE



5126
Bell System New York Telephone Company Porcelain Flange Sign
 \$300 - \$500 OFFERED WITHOUT RESERVE



5127
"Drink Ski" with Bottle Water Skiing Logo Metal Sign
 \$600 - \$900 OFFERED WITHOUT RESERVE



5128
"Enjoy Orange Crush" Bottle Cap Metal Sign
 \$400 - \$600 OFFERED WITHOUT RESERVE



5129
"Coca-Cola Sold Here Ice Cold" Arrow Sign
 \$600 - \$900 OFFERED WITHOUT RESERVE



5130
"Ice Cold Mir-Che" with Bottle Metal Sign
 \$300 - \$500 OFFERED WITHOUT RESERVE



5131
Drink Hires with Bottle Tin Thermometer
 \$200 - \$400 OFFERED WITHOUT RESERVE



5132
Pepsi-Cola Metal Tray, Pepsi-Cola "Big Shot" Poster, and Barq's Sign
 \$100 - \$300 OFFERED WITHOUT RESERVE



5133
Pacific Piston Rings "Power-Precision-Economy" with Cars Very Rare Porcelain Sign
 \$4,000 - \$6,000



5134
Balsam-Wool Blanket Porcelain Sign
 \$400 - \$700 OFFERED WITHOUT RESERVE



5135
Vespa Service Porcelain Sign
 \$1,500 - \$3,000 OFFERED WITHOUT RESERVE



5136
Auto-Lite Batteries with Car Metal Sign
 \$1,000 - \$1,500 OFFERED WITHOUT RESERVE



5137
Shell Motor Oils with Red Logo Porcelain Sign
 \$750 - \$1,250 OFFERED WITHOUT RESERVE



5138
"Aeroshell Lubricating Oil Stocked Here" Porcelain Sign
 \$2,000 - \$3,000 OFFERED WITHOUT RESERVE



5139
Shell "From the Pump" Arrow Porcelain Sign
 \$2,000 - \$3,000 OFFERED WITHOUT RESERVE



5140
Shell "Stop Your Motor Please No Smoking" Porcelain Sign
 \$500 - \$1,000 OFFERED WITHOUT RESERVE



5141
"United Motors Authorized Service" with Delco-Remy and Klaxon Bottom Panels Porcelain Sign
 \$5,000 - \$8,000 OFFERED WITHOUT RESERVE



5142
"United Motors Service" Arrow Porcelain Sign
 \$5,000 - \$8,000 OFFERED WITHOUT RESERVE



5143
Texaco "Black-T" "Clean, Clear, Golden" Porcelain Flange Sign
 \$2,000 - \$3,000 OFFERED WITHOUT RESERVE



5144
"Harris Medium Soline Engine Cylinder Oil" Porcelain Flange Sign
 \$1,000 - \$2,000 OFFERED WITHOUT RESERVE



5145
"Firestone Tires Garage Gasoline" Porcelain Flange Sign
 \$3,000 - \$4,000 OFFERED WITHOUT RESERVE



5146
 "Shell Motor Oil" Porcelain Sign
 \$1,500 - \$3,000 OFFERED WITHOUT RESERVE



5147
 "Genuine Ford Battery Sales-
 Service" Porcelain Sign
 \$2,500 - \$3,500 OFFERED WITHOUT RESERVE



5148
 "Genuine Ford Parts Sold
 Here" Porcelain Sign
 \$2,000 - \$3,000 OFFERED WITHOUT RESERVE



5149
 "Genuine Ford Parts Used
 Here" Porcelain Sign
 \$1,000 - \$2,000 OFFERED WITHOUT RESERVE



5150
 Ford Sales and Service 'Small
 Pyramid' Porcelain Sign
 \$2,000 - \$3,000 OFFERED WITHOUT RESERVE



5151
 Ford "The Universal Car" 'Small
 Pyramid' Porcelain Sign
 \$2,000 - \$3,000 OFFERED WITHOUT RESERVE



5152
 Ford Medium Oval Porcelain Sign
 \$2,000 - \$3,000 OFFERED WITHOUT RESERVE



5153
 "Service Entrance" Porcelain Arrow Sign
 \$600 - \$1,200 OFFERED WITHOUT RESERVE



5154
 "Mobilgas" Truck Valance Porcelain Sign
 \$600 - \$1,200 OFFERED WITHOUT RESERVE



5155
 1911 Elmore Car Sold by Dunbar
 & Mansir Poster
 \$200 - \$400 OFFERED WITHOUT RESERVE



5156
 Chevrolet in Bowtie "Service" Porcelain Sign
 \$750 - \$1,500 OFFERED WITHOUT RESERVE



5157
 "Shell Chassis and Motor
 Lubrication" Porcelain Sign
 \$2,000 - \$3,000 OFFERED WITHOUT RESERVE



5158
 "Genuine Ford Parts" Oval Porcelain Sign
 \$2,000 - \$3,000 OFFERED WITHOUT RESERVE



5159
 "Genuine Chevrolet Parts" Porcelain Sign
 \$3,000 - \$4,000 OFFERED WITHOUT RESERVE



5160
 Original "Esso Elephant
 Kerosene" Porcelain Sign
 \$400 - \$700 OFFERED WITHOUT RESERVE



5161
 "FoMoCo Genuine Ford Parts" Metal Sign
 \$600 - \$1,000 OFFERED WITHOUT RESERVE



5162
 "Robert B. Doe Oil Field Service"
 Truck Door Porcelain Sign
 \$600 - \$1,000 OFFERED WITHOUT RESERVE



5163
 Republic 'Gas' with Shield Logo Porcelain Sign
 \$600 - \$900 OFFERED WITHOUT RESERVE



5164
 "Mobilgas Special Gasoline" with
 Drop-Leg Logo Porcelain Sign
 \$600 - \$900 OFFERED WITHOUT RESERVE



5165
 Original "Humble" Truck Door Porcelain Sign
 \$400 - \$800 OFFERED WITHOUT RESERVE



5166
 "The Atlantic Refining Company"
 'Fried Egg' Logo Porcelain Sign
 \$600 - \$1,000 OFFERED WITHOUT RESERVE



5167
 Texaco 'White-T' "Fire Chief Gasoline"
 Medium Porcelain Sign
 \$300 - \$500 OFFERED WITHOUT RESERVE



5168
 "Monogram Greases Oils" Rare and
 Early Porcelain Flange Sign
 \$750 - \$1,250 OFFERED WITHOUT RESERVE



5169
 Auto-Lite "Ask About Sta-Ful"
 '6-Volt Batteries' Metal Rack Sign
 \$300 - \$500 OFFERED WITHOUT RESERVE



5170
 Mirco-Lube with Jet Plane
 Graphic Metal Rack Sign
 \$400 - \$700 OFFERED WITHOUT RESERVE



5171
 Mansfield Tires "Built to
 Overage" Metal Sign
 \$400 - \$800 OFFERED WITHOUT RESERVE



5172
 Victor Tires with Logo Tin Flange Sign
 \$500 - \$900 OFFERED WITHOUT RESERVE



5173
 "Emergency ALA Service" Porcelain Sign
 \$300 - \$500 OFFERED WITHOUT RESERVE



5174
 "Schock Independent Oil Co. Gasoline
 Motor Oil" Porcelain Flange Sign
 \$500 - \$900 OFFERED WITHOUT RESERVE



5175
 "Gargoyle Mobiloil Vacuum Oil
 Company" Porcelain Flange Sign
 \$750 - \$1,250 OFFERED WITHOUT RESERVE



5176
 BP Fuel Porcelain Flange Sign
 \$600 - \$1,000 OFFERED WITHOUT RESERVE



5177
 John Deere 2-Legged Logo Metal Sign
 \$500 - \$900 OFFERED WITHOUT RESERVE



5178
 "FoMoCo Genuine Ford Parts"
 Metal Cabinet with Product
 \$400 - \$700 OFFERED WITHOUT RESERVE



5179
 Ask for AC Spark Plugs "Standard Spark Plug
 of the World" Metal Countertop Display
 \$600 - \$1,000 OFFERED WITHOUT RESERVE



5180
 GMC Original Window Neon Sign
 \$200 - \$400 OFFERED WITHOUT RESERVE



5181
 "Goodrich Securite" with Boy
 Carryng a Tire by Geo Ham
 \$1,000 - \$1,600 OFFERED WITHOUT RESERVE



5182
 Texaco 'Black-T' "Free Crankcase
 Service" Porcelain Sign
 \$1,500 - \$2,500 OFFERED WITHOUT RESERVE



5183
 "Goodyear Service Station" with World
 in Tire Logo Porcelain Flange Sign
 \$6,000 - \$9,000 OFFERED WITHOUT RESERVE



5184
 Dance Tippy with Couple Wooden Sign
 \$300 - \$500 OFFERED WITHOUT RESERVE



5185
 Studabaker Front Clip Wall Sculpture
 \$400 - \$600 OFFERED WITHOUT RESERVE



5187
 "Shell Huiles Pour Moteurs" Porcelain Sign
 \$750 - \$1,500 OFFERED WITHOUT RESERVE



5188
 Phillips 66 "Red and Black" Porcelain Sign
 \$1,500 - \$2,500 OFFERED WITHOUT RESERVE



5189
 "Quaker Maid Milk First in Quality"
 with Logo Porcelain Sign
 \$750 - \$1,500 OFFERED WITHOUT RESERVE



5190
 "Shamrock Dairy" with Bottle
 and Carton Porcelain Sign
 \$500 - \$900 OFFERED WITHOUT RESERVE



5191
 White Trucks "Gas-Diesel Parts & Service"
 with Four Different Logos Porcelain Sign
 \$1,500 - \$2,500 OFFERED WITHOUT RESERVE



5192
 "Gargoyle Mobiloil Certified
 Service" Porcelain Sign
 \$1,000 - \$1,600 OFFERED WITHOUT RESERVE



5193
 "Gargoyle Marine Oils" 'Mobiloil'
 with Pegasus Porcelain Sign
 \$3,000 - \$5,000 OFFERED WITHOUT RESERVE



5194
 Mobilgas Special with Pegasus Porcelain Sign
 \$200 - \$400 OFFERED WITHOUT RESERVE



5195
 Mobilgas with Pegasus Porcelain Sign
 \$200 - \$400 OFFERED WITHOUT RESERVE



5196
 "G&J Tires" with Logo Porcelain Sign
 \$750 - \$1,250 OFFERED WITHOUT RESERVE



5197
 GM Quality Service Parts Lighted Plastic Sign
 \$400 - \$700 OFFERED WITHOUT RESERVE



5198
 "Factory Parts Engineered" 'Pontiac'
 with Logo Porcelain Sign
 \$1,500 - \$2,500 OFFERED WITHOUT RESERVE



5199
 Chevrolet in Bowtie Porcelain Sign
 \$1,500 - \$3,000 OFFERED WITHOUT RESERVE



5200
 Socony "Friendly Service"
 Porcelain Thermometer
 \$400 - \$700 OFFERED WITHOUT RESERVE



5201
 Prestone Anti-Freeze Round
 Porcelain Thermometer
 \$500 - \$900 OFFERED WITHOUT RESERVE



5202
 "Texaco Motor Oil Heavy" Easy Pour Can
 \$600 - \$1,200 OFFERED WITHOUT RESERVE



5203
 Mercedes-Benz Porcelain Sign
 \$1,000 - \$2,000 OFFERED WITHOUT RESERVE



5204
 Texaco 'Black-T' "No Smoking" Porcelain Sign
 \$3,000 - \$4,000 OFFERED WITHOUT RESERVE



5205
 Hancock 'Modern Rooster' "No Smoking
 Stop Motor" Porcelain Sign
 \$2,000 - \$3,000 OFFERED WITHOUT RESERVE



5206
 Union 76 "Stop Your Motor No
 Smoking Porcelain Sign"
 \$500 - \$900 OFFERED WITHOUT RESERVE



5207
Standard 'ESSO' "No Smoking" Porcelain Sign
\$300 - \$500 OFFERED WITHOUT RESERVE



5208
Multi-Color Chevrolet in Bowtie Porcelain Sign
\$1,500 - \$2,500 OFFERED WITHOUT RESERVE



5209
Chevrolet in Bowtie "Motor Cars" Porcelain Sign
\$1,000 - \$2,000 OFFERED WITHOUT RESERVE



5210
"ESSO Elephant Kerosene" Porcelain Sign
\$100 - \$200 OFFERED WITHOUT RESERVE



5211
Pegasus 'Mobil' Porcelain Sign
\$1,000 - \$2,000 OFFERED WITHOUT RESERVE



5212
"We Use Genuine Chevrolet Parts" Tin Flange Sign
\$1,500 - \$2,500 OFFERED WITHOUT RESERVE



5213
"ESSO Aviation Products" Metal Sign
\$750 - \$1,500 OFFERED WITHOUT RESERVE



5214
"Francisco Auto Heater" Metal Sign
\$2,500 - \$3,500 OFFERED WITHOUT RESERVE



5215
Red Crown Gasoline "for Power Service Economy" Porcelain Thermometer
\$2,000 - \$3,000 OFFERED WITHOUT RESERVE



5216
Pegasus 'Mobil' Embossed Porcelain Sign
\$2,000 - \$3,000 OFFERED WITHOUT RESERVE



5217
"Socony-Vacuum" with Pegasus Small Identification Porcelain Sign
\$3,000 - \$5,000 OFFERED WITHOUT RESERVE



5218
"Sinclair Opaline Motor Oil" with Can Porcelain Sign
\$2,000 - \$3,000 OFFERED WITHOUT RESERVE



5219
"Sinclair H-C Gasoline" Small Porcelain Sign
\$3,000 - \$4,000 OFFERED WITHOUT RESERVE



5220
"Gargoyle Mobiloil Certified Service" "Cleared" Porcelain Sign
\$300 - \$600 OFFERED WITHOUT RESERVE



5221
"Ask for Gargoyle Mobiloil Authorized Service" Porcelain Sign
\$750 - \$1,250 OFFERED WITHOUT RESERVE



5222
Texaco "Black-T" Motor Oil Porcelain Sign
\$750 - \$1,500 OFFERED WITHOUT RESERVE



5223
Texaco "8-Ball" with Ethyl Logo Porcelain Sign
\$1,000 - \$2,000 OFFERED WITHOUT RESERVE



5224
No-Nox Ethyl with Logo Porcelain Sign
\$1,500 - \$2,500 OFFERED WITHOUT RESERVE



5225
Texaco "White-T" "Marine Lubricants" Porcelain Sign
\$3,000 - \$5,000 OFFERED WITHOUT RESERVE



5226
"Socony Air-Craft Oils" with Plane Porcelain Sign
\$3,000 - \$4,000 OFFERED WITHOUT RESERVE



5227
Wolf's Head Oil "A Revelation in Lubrication" Porcelain Sign
 \$3,000 - \$4,000 OFFERED WITHOUT RESERVE



5228
Power-lube Motor Oil with Logo Porcelain Sign
 \$3,000 - \$4,000 OFFERED WITHOUT RESERVE



5229
Ford V-8 Genuine Parts Porcelain Sign
 \$2,500 - \$3,500 OFFERED WITHOUT RESERVE



5230
Super Chevrolet Service Rare Sized Porcelain Sign
 \$4,000 - \$6,000 OFFERED WITHOUT RESERVE



5231
Shell "Certified System of Lubrication" Porcelain Sign
 \$2,000 - \$3,000 OFFERED WITHOUT RESERVE



5232
La Salle 'Gas' Gill Globe Lenses in an Original Red Ripple Body
 \$3,000 - \$4,000 OFFERED WITHOUT RESERVE



5233
Super-Shell 'Gas' One Piece Etched Milk Glass Canteen Globe Body
 \$1,000 - \$2,000 OFFERED WITHOUT RESERVE



5234
Chevrolet Porcelain Face Round Thermometer
 \$8,000 - \$12,000 OFFERED WITHOUT RESERVE



5235
Skelly Regular Globe Lenses 13.5 in.
 \$300 - \$500 OFFERED WITHOUT RESERVE



5236
Montgomery Ward Porcelain Sign
 \$600 - \$1,200 OFFERED WITHOUT RESERVE



5237
"Texaco Industrial Lubricants" Metal Sign
 \$150 - \$300 OFFERED WITHOUT RESERVE



5238
Sinclair with Dino Small Identification Sign
 \$1,000 - \$2,000 OFFERED WITHOUT RESERVE



5239
Gulf "New Logo" Porcelain Identification Sign
 \$750 - \$1,250 OFFERED WITHOUT RESERVE



5240
"PKG. Liquors" Neon Store Sign Skin
 \$500 - \$1,000 OFFERED WITHOUT RESERVE



5241
Lubrication "Sinclair" Porcelain Sign
 \$400 - \$600 OFFERED WITHOUT RESERVE



5242
"Approved Clean Rest Rooms" Porcelain Sign
 \$200 - \$400 OFFERED WITHOUT RESERVE



5243
Studebaker Wood Box
 \$200 - \$400 OFFERED WITHOUT RESERVE



5244
U-P Brake Service Metal Sign
 \$400 - \$600 OFFERED WITHOUT RESERVE



5245
"Winchester Gun Advisory Center" Metal Sign
 \$600 - \$800 OFFERED WITHOUT RESERVE



5246
Tydol with Ethyl Logo Porcelain Sign
 \$1,500 - \$2,500 OFFERED WITHOUT RESERVE



5247
 Goodrich Silvertowns with Tire and Red Tube Porcelain Sign
 \$2,000 - \$3,000 OFFERED WITHOUT RESERVE



5248
 "Mercedes-Benz Service" with Logo Porcelain Sign
 \$3,000 - \$4,000 OFFERED WITHOUT RESERVE



5249
 Texaco "Gasoline Filling Station" Porcelain Sign
 \$3,000 - \$4,000 OFFERED WITHOUT RESERVE



5250
 Texaco "Black-T" Gasoline Motor Oil Porcelain Sign
 \$3,500 - \$4,500 OFFERED WITHOUT RESERVE



5251
 Texaco "Black-T" "Lubricating Oil Motor Oil" Porcelain Sign
 \$3,000 - \$5,000 OFFERED WITHOUT RESERVE



5252
 Pontiac Service with Stars and Full Feather Logo Porcelain Sign
 \$3,000 - \$4,000 OFFERED WITHOUT RESERVE



5253
 Firestone Vertical Metal Sign
 \$600 - \$1,200 OFFERED WITHOUT RESERVE



5254
 "Cadillac V8, V12, V16 La Salle V8" Rare Porcelain Sign
 \$6,000 - \$9,000 OFFERED WITHOUT RESERVE



5255
 Ford Service Entrance Porcelain Sign
 \$2,000 - \$3,000 OFFERED WITHOUT RESERVE



5256
 Shell Gasoline with Roxanna Logo Porcelain Sign
 \$4,000 - \$6,000 OFFERED WITHOUT RESERVE



5257
 Shell Motor Oil Porcelain Sign
 \$3,000 - \$5,000 OFFERED WITHOUT RESERVE



5258
 Golden Shell Motor Oil Large Porcelain Sign
 \$2,500 - \$3,500 OFFERED WITHOUT RESERVE



5259
 "Chevrolet for Economical Transportation Sales & Service" Porcelain Sign
 \$3,500 - \$5,000 OFFERED WITHOUT RESERVE



5260
 "Shell-Penn 100% Pure Pennsylvania Motor Oil" Porcelain Sign
 \$1,500 - \$2,500 OFFERED WITHOUT RESERVE



5261
 Shell Gasoline Porcelain Sign
 \$2,500 - \$3,500 OFFERED WITHOUT RESERVE



5262
 ESSO with Ethyl Logo Porcelain Sign
 \$3,000 - \$4,000 OFFERED WITHOUT RESERVE



5263
 Buick Valve in Head Authorized Service Porcelain Sign
 \$2,500 - \$3,500 OFFERED WITHOUT RESERVE



5264
 Cadillac Authorized Service with Crest Logo "Dark" Porcelain Sign
 \$3,000 - \$5,000 OFFERED WITHOUT RESERVE



5265
 Shell Motor Oil Porcelain Sign
 \$2,000 - \$3,000 OFFERED WITHOUT RESERVE



5266
 Michelin Tires with Smoking Bibendum Porcelain Flange Sign
 \$5,000 - \$7,500 OFFERED WITHOUT RESERVE



5267
Michelin Tires with Bibendum
Sitting in a Tire Porcelain Sign
 \$4,000 - \$6,000 OFFERED WITHOUT RESERVE



5268
"Michelin Tires & Tubes" with Bibendum
Sitting in a Tire Porcelain Sign
 \$4,000 - \$6,000 OFFERED WITHOUT RESERVE



5269
Shell Porcelain Sign
 \$1,000 - \$2,000 OFFERED WITHOUT RESERVE



5270
Mobiloil Aero "America's Quality
Aviation Oil" Metal Can Rack
 \$750 - \$1,500 OFFERED WITHOUT RESERVE



5271
Mobiloil Fil-Pruf Motor Oil Bottles in Rack
 \$3,000 - \$4,000 OFFERED WITHOUT RESERVE



5272
Mobiloil Gargoyle Authorized
Service Oil Bottle Rack
 \$1,000 - \$2,000 OFFERED WITHOUT RESERVE



5273
Pegasus 'Mobil' Weathervane
 \$3,000 - \$4,000 OFFERED WITHOUT RESERVE



5274
Pontiac Neon Clock with Full Feather Logo
 \$1,500 - \$2,500 OFFERED WITHOUT RESERVE



5275
Kaiser Frazer Approved Service Porcelain Sign
 \$1,000 - \$2,000 OFFERED WITHOUT RESERVE



5276
Mr. Goodwrench "Tune-Up
Special" Metal Sign
 \$150 - \$300 OFFERED WITHOUT RESERVE



5277
DX 3-Dimensional Multi-Piece Porcelain Sign
 \$1,000 - \$2,000 OFFERED WITHOUT RESERVE



5278
Raybestos Fan Belts Display
 \$300 - \$600 OFFERED WITHOUT RESERVE



5279
Gulflube Motor Oil Can Rack Display
 \$400 - \$700 OFFERED WITHOUT RESERVE



5280
Monroe Load-Leveler Shock Display
 \$200 - \$400 OFFERED WITHOUT RESERVE



5281
Socony Fuel Oil Cardboard Poster
 \$100 - \$300 OFFERED WITHOUT RESERVE



5282
GCC Glide Control Countertop Display
 \$300 - \$600 OFFERED WITHOUT RESERVE



5283
"Windshield Service" Towel
Cabinet NIB with Shell Decal
 \$200 - \$400 OFFERED WITHOUT RESERVE



5284
Kendall "The 2000 Mile Oil" with
Logo Neon Spinner Clock
 \$1,000 - \$2,000 OFFERED WITHOUT RESERVE



5285
Chevrolet "Time" Neon Clock
from Guy Clements, MD.
 \$1,000 - \$2,000 OFFERED WITHOUT RESERVE



5286
Texaco 'Gas' Leaded Slag Glass Window
 \$1,000 - \$2,000 OFFERED WITHOUT RESERVE



5287
 "Ask here for Gargoyle Mobiloil"
 Curb Porcelain Sign
 \$1,000 - \$2,000 OFFERED WITHOUT RESERVE



5289
 Dodge Brothers Approved Service
 Station Porcelain Sign
 \$2,000 - \$3,000 OFFERED WITHOUT RESERVE



5290
 Whippet Overland Willys Knight
 Emile Quesnel Porcelain Sign
 \$1,500 - \$2,500 OFFERED WITHOUT RESERVE



5292
 Sunbeam Batter Whipped
 'Bread' Metal Door Push
 \$300 - \$500 OFFERED WITHOUT RESERVE



5293
 "Dixon & Sons Chemists High Class
 Mineral Water" Porcelain Sign
 \$400 - \$600 OFFERED WITHOUT RESERVE



5294
 Texaco "Black-T" Star Logo
 Large Porcelain Sign
 \$600 - \$1,000 OFFERED WITHOUT RESERVE



5295
 "Lackawanna Anthracite The D&H"
 Truck Door Porcelain Sign
 \$400 - \$700 OFFERED WITHOUT RESERVE



5296
 Conoco "Do Not Oil While In Motion"
 with Logo Porcelain Sign
 \$200 - \$400 OFFERED WITHOUT RESERVE



5297
 Otto Coke 'Coal' Porcelain Sign
 \$400 - \$700 OFFERED WITHOUT RESERVE



5298
 Indio Gas Co. Porcelain Sign
 \$500 - \$800 OFFERED WITHOUT RESERVE



5299
 B.O.C. Kerosene Porcelain Flange Sign
 \$300 - \$500 OFFERED WITHOUT RESERVE



5300
 "Please Drive Slowly Sound
 Klaxon" Rare Porcelain Sign
 \$300 - \$500 OFFERED WITHOUT RESERVE



5301
 "Agency Alfred Peats Prize Wall
 Paper" Porcelain Sign
 \$400 - \$700 OFFERED WITHOUT RESERVE



5302
 Binks 'Paint Guns' Porcelain Sign
 \$200 - \$400 OFFERED WITHOUT RESERVE



5303
 "Quaker State Duplex Outboard
 Oil" Chalkboard Sign
 \$200 - \$400 OFFERED WITHOUT RESERVE



5304
 Husky Oil "Caution High Pressure
 Oil Pipeline" Metal Sign
 \$200 - \$400 OFFERED WITHOUT RESERVE



5305
 Enjoy Teem "a Lemon-Lime Drink" Metal Sign
 \$400 - \$800 OFFERED WITHOUT RESERVE



5306
 Vernor's Ginger Ale with Logo Metal Sign
 \$300 - \$600 OFFERED WITHOUT RESERVE



5307
 "Coca-Cola Ice Cold Sold Here" with
 Trademark Original Metal Sign
 \$600 - \$900 OFFERED WITHOUT RESERVE



5308
 Duxbak Utica Corp Original Metal Sign
 \$400 - \$700 OFFERED WITHOUT RESERVE



5309
Lucas Service "Parts for Imported Cars" Metal Sign
\$200 - \$400 OFFERED WITHOUT RESERVE



5310
"Milk Meda-Goddess of the Rockies" Metal Sign
\$200 - \$400 OFFERED WITHOUT RESERVE



5311
Follo Light Bracket "The Light that Follows the Road" Paper Sign
\$300 - \$600 OFFERED WITHOUT RESERVE



5312
Warren Automobile Picnic Set
\$300 - \$600 OFFERED WITHOUT RESERVE



5313
"Vernor's Ginger Ale Deliciously Different" Fountain Dispenser
\$1,000 - \$1,750 OFFERED WITHOUT RESERVE



5314
"Eisenlohr's Cinco Cigars" Porcelain Sign
\$400 - \$700 OFFERED WITHOUT RESERVE



5315
"Arcadian "The American" Nitrate of Soda" with Uncle Sam Logo Porcelain Sign
\$500 - \$900 OFFERED WITHOUT RESERVE



5316
BOVAG with Auto Driving Thru the "O" Porcelain Sign
\$500 - \$900 OFFERED WITHOUT RESERVE



5317
"Allis-Chalmers Tractors Parts & Service" Porcelain Sign
\$750 - \$1,250 OFFERED WITHOUT RESERVE



5318
"Close Side Caution Clearance" "Railroad" Porcelain Sign
\$200 - \$400 OFFERED WITHOUT RESERVE



5319
Warning List "Mobil" Porcelain Sign
\$100 - \$300 OFFERED WITHOUT RESERVE



5320
"Bougie Gergovia" Spark Plug Metal Sign
\$200 - \$400 OFFERED WITHOUT RESERVE



5321
"Reliance Adv. Co. Porcelain Enameled Advertising Signs"
\$400 - \$800 OFFERED WITHOUT RESERVE



5322
"Public Telephone United Utilities System" Porcelain Flange Sign
\$250 - \$400 OFFERED WITHOUT RESERVE



5323
"We Sell Horse Shoe Tobacco" Porcelain Flange Sign
\$400 - \$700 OFFERED WITHOUT RESERVE



5324
"Star Tobacco Sold Here" Porcelain Sign
\$600 - \$900 OFFERED WITHOUT RESERVE



5325
"Genuine Ford Anti-Freeze" One Gallon Flat Metal Can
\$400 - \$700 OFFERED WITHOUT RESERVE



5326
"Ford Anti-Freeze" One Gallon Flat Metal Can
\$300 - \$500 OFFERED WITHOUT RESERVE



5327
"Illinois Farm Supply Company" Motor Oil One Gallon Flat Metal Can
\$150 - \$300 OFFERED WITHOUT RESERVE



5328
"Harley-Davidson Pre-Luxe Motorcycle Oil" Metal Quart Can
\$150 - \$300 OFFERED WITHOUT RESERVE



5329
Full Spark Plug Boxes
\$150 - \$300 OFFERED WITHOUT RESERVE



5330
National Highway Association
Eagle on Globe Mascot
\$200 - \$400 OFFERED WITHOUT RESERVE



5331
NMA Illinois Assoc. Radiator
Badge & Lincoln V-12 Badge
\$200 - \$400 OFFERED WITHOUT RESERVE



5333
"The Raleigh Nottingham
England" Bicycle Sign
\$300 - \$600 OFFERED WITHOUT RESERVE



5334
1932 Alfa Romeo Spider Touring
Gran Sport 1932 Plastic Model
\$200 - \$400 OFFERED WITHOUT RESERVE



5335
Automotive Dash Clusters
\$200 - \$400 OFFERED WITHOUT RESERVE



5336
Top Value Stamps Metal Sign
\$300 - \$500 OFFERED WITHOUT RESERVE



5337
"Better Meats Cleaner Meats
Quicker Service" Porcelain Sign
\$150 - \$300 OFFERED WITHOUT RESERVE



5338
Indiana Leather License Plate No. 507
\$400 - \$700 OFFERED WITHOUT RESERVE



5339
Leather License Plate No. 47
\$600 - \$800 OFFERED WITHOUT RESERVE



5340
Miller Tires Porcelain Sign
\$500 - \$800 OFFERED WITHOUT RESERVE



5341
"Ford Authorized Service Station Using
Genuine Ford Parts" Porcelain Sign
\$600 - \$1,200 OFFERED WITHOUT RESERVE



5342
"Ford Sales and Service Cars-
Trucks-Tractors" Porcelain Sign
\$1,000 - \$1,500 OFFERED WITHOUT RESERVE



5343
"Ford Authorized Sales and
Service" Porcelain Sign
\$2,000 - \$3,000 OFFERED WITHOUT RESERVE



5344
"Ford Lincoln Fordson Sales and Service
Cars-Trucks-Tractors" Porcelain Sign
\$750 - \$1,500 OFFERED WITHOUT RESERVE



5345
Ford in Oval Porcelain Sign
\$300 - \$500 OFFERED WITHOUT RESERVE



5346
"Ford Sales and Service" "Small
Pyramid" Porcelain Sign
\$600 - \$1,200 OFFERED WITHOUT RESERVE



5347
"Ford The Universal Car" "Small
Pyramid" Porcelain Sign
\$600 - \$1,200 OFFERED WITHOUT RESERVE



5348
"Ford Service The Universal Car"
One Piece Etched Canopy Globe
\$8,000 - \$12,000 OFFERED WITHOUT RESERVE



5349
Multi-Color Chevrolet in Bowtie
Neon Porcelain Sign
\$1,000 - \$2,000 OFFERED WITHOUT RESERVE



5350
Mobiloil Fil-Pruf Motor Oil Bottles
\$750 - \$1,400 OFFERED WITHOUT RESERVE



5351
Amoco Peralube 120 LB. Gear Oil Can
\$200 - \$400 OFFERED WITHOUT RESERVE



5352
Large Embossed Shell Porcelain Sign
\$600 - \$1,200 OFFERED WITHOUT RESERVE



5353
Large Embossed Shell Porcelain Sign
\$1,000 - \$1,500 OFFERED WITHOUT RESERVE



5354
Shell Restroom Porcelain Flange Sign
\$200 - \$300 OFFERED WITHOUT RESERVE



5356
Assortment of Plastic Shell Letters
\$100 - \$200 OFFERED WITHOUT RESERVE



5357
Old Style Five Gallon Gas Cans
\$200 - \$400 OFFERED WITHOUT RESERVE



5358
Agua Systems No. 855 Computing Gas Pump
\$200 - \$400 OFFERED WITHOUT RESERVE



5359
Weaver Alignment Display Stand
\$100 - \$200 OFFERED WITHOUT RESERVE



5360
American Oil Pump & Tank Lubster
\$200 - \$300 OFFERED WITHOUT RESERVE



5361
American Oil Pump & Tank Lubster
\$200 - \$300 OFFERED WITHOUT RESERVE



5362
Miscellaneous Shell Oil Cans and More
\$200 - \$300 OFFERED WITHOUT RESERVE



5363
Mobiloil with Pegasus Keyhole Porcelain Sign
\$500 - \$900 OFFERED WITHOUT RESERVE



5364
Dairy Queen Lighted Sign
\$500 - \$800 OFFERED WITHOUT RESERVE



5365
WWI "Invest in the Victory Liberty Loan" Poster with Submarine
\$200 - \$300 OFFERED WITHOUT RESERVE



5366
"Eternal Band of Brothers" Korea War Print
\$100 - \$200 OFFERED WITHOUT RESERVE



5367
Buddy L "BLFD" Fire Engine Peddle Toy
\$200 - \$300 OFFERED WITHOUT RESERVE



5368
Goodyear Tires with Logo Vertical Porcelain Sign
\$500 - \$750 OFFERED WITHOUT RESERVE



5369
1935-36 Auburn "Mercury" Hood Ornate
\$300 - \$500 OFFERED WITHOUT RESERVE



5370
Glidden "Paint" Porcelain Sign
\$100 - \$200 OFFERED WITHOUT RESERVE



5371
Stop Sign with Reflective Marbles
 \$150 - \$250 OFFERED WITHOUT RESERVE



5372
"Quaker State Motor Oil" Tombstone Sign
 \$200 - \$300 OFFERED WITHOUT RESERVE



5373
Sinclair Branded Gas Can
 \$150 - \$250 OFFERED WITHOUT RESERVE



5374
"Drink Ice Cold Coca-Cola" Double-Sided Flange Sign
 \$150 - \$250 OFFERED WITHOUT RESERVE



5375
Yugo Dealership Sign
 \$500 - \$700 OFFERED WITHOUT RESERVE



5376
"Sinclair H-C Gasoline" Sign
 \$1,200 - \$1,500 OFFERED WITHOUT RESERVE



5377
B.F. Goodrich Tires Sign
 \$100 - \$150 OFFERED WITHOUT RESERVE



5378
Refinished Oilers
 \$200 - \$300 OFFERED WITHOUT RESERVE



5379
Refinished Texaco Branded Lubster
 \$100 - \$150 OFFERED WITHOUT RESERVE



5380
Modern Illuminated Chevrolet Bowtie Sign
 \$1,500 - \$2,000 OFFERED WITHOUT RESERVE



5381
Pepsi Clock
 \$150 - \$200 OFFERED WITHOUT RESERVE



5382
Ford Dealership "Entrance" Sign
 \$400 - \$600 OFFERED WITHOUT RESERVE



5383
Wixom Rd and Grand River Ave Street Signs
 \$400 - \$600 OFFERED WITHOUT RESERVE



5384
Mobil Gas Plastic Sign
 \$400 - \$600 OFFERED WITHOUT RESERVE



5385
Texaco I.D. Porcelain Sign
 \$4,000 - \$5,000 OFFERED WITHOUT RESERVE



5386
Citgo Gas Plastic Sign
 \$400 - \$600 OFFERED WITHOUT RESERVE



5387
"RAC Repairer" Porcelain Sign
 \$600 - \$800 OFFERED WITHOUT RESERVE



5388
"We Sell Socony Motor Gasoline" Porcelain Flange Sign
 \$2,500 - \$3,500 OFFERED WITHOUT RESERVE



5389
Assorted Street Signs
 \$400 - \$600 OFFERED WITHOUT RESERVE



5390
"Doral Premium Taste" Cigarettes Neon Sign
 \$75 - \$100 OFFERED WITHOUT RESERVE



5391
Dodge Trucks Silk Dealership Banner
 \$100 - \$150 OFFERED WITHOUT RESERVE



5392
Street Light and Standing Street Light
 \$150 - \$200 OFFERED WITHOUT RESERVE



5393
North Electric Co. Telephone
 \$150 - \$200 OFFERED WITHOUT RESERVE



5394
Kicker Automotive Speaker Systems Lighted Sign, Cooper Tires Lighted Sign with Clock, Autolite Batteries Lighted Sign with Clock
 \$300 - \$400 OFFERED WITHOUT RESERVE



5395
National, Uniroyal, and Dunlop Tires Signs
 \$1,500 - \$2,000 OFFERED WITHOUT RESERVE



5396
Kleenex Tissues Pocket-Pack Wall Dispenser
 \$150 - \$200 OFFERED WITHOUT RESERVE



5397
Stokol Stoker Double-Sided Flange Sign
 \$150 - \$200 OFFERED WITHOUT RESERVE



5398
Hires Root Beer Cooler With Taps
 \$250 - \$350 OFFERED WITHOUT RESERVE



5399
World's Fair 1939 New York Folding Chair
 \$50 - \$75 OFFERED WITHOUT RESERVE



5400
Snackmaster Cooler and Magikooler Portable Ice Chest
 \$100 - \$150 OFFERED WITHOUT RESERVE



5401
Tartan Picnic Sets
 \$100 - \$150 OFFERED WITHOUT RESERVE



5402
Travel Bars
 \$150 - \$200 OFFERED WITHOUT RESERVE



5403
Mercury Sofa
 \$2,500 - \$3,500 OFFERED WITHOUT RESERVE



5404
Butler and Chef
 \$50 - \$75 OFFERED WITHOUT RESERVE



5404A
Cabinet Bar
 \$400 - \$600 OFFERED WITHOUT RESERVE



5405
Wood Auditorium Seats
 \$75 - \$100 OFFERED WITHOUT RESERVE



5406
Large Soda Keg
 \$350 - \$450 OFFERED WITHOUT RESERVE



5407
Vintage Sporting Goods
 \$50 - \$75 OFFERED WITHOUT RESERVE



5408
Salesman's Sample Ovens
 \$400 - \$600 OFFERED WITHOUT RESERVE



5409
National Electric Timecard Machine
 \$400 - \$600 OFFERED WITHOUT RESERVE



5410
Ashtray with Globe
\$175 - \$225 OFFERED WITHOUT RESERVE



5411
Badger's, Queen, and Quick-Aid Fire Extinguishers
\$100 - \$150 OFFERED WITHOUT RESERVE



5412
Ashtray With Sailboat
\$100 - \$150 OFFERED WITHOUT RESERVE



5413
International Tailoring Co. 1932 Spring and Summer All Wool Line Book
\$50 - \$75 OFFERED WITHOUT RESERVE



5414
Round Oak Wood Stove
\$400 - \$600 OFFERED WITHOUT RESERVE



5415
Children's Car Wagon
\$200 - \$300 OFFERED WITHOUT RESERVE



5416
Vintage Grease Guns and Oil Fillers
\$200 - \$300 OFFERED WITHOUT RESERVE



5417
Vintage Oil Cans with Displays
\$400 - \$600 OFFERED WITHOUT RESERVE



5418
Atlas Battery Charger
\$200 - \$300 OFFERED WITHOUT RESERVE



5419
Trico Windshield Wiper Countertop Display
\$200 - \$300 OFFERED WITHOUT RESERVE



5420
Castrol Oiler
\$200 - \$300 OFFERED WITHOUT RESERVE

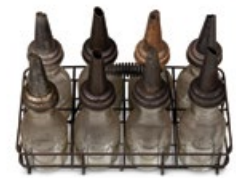

5421
Quart Bottles with Carrier and Rack
\$200 - \$300 OFFERED WITHOUT RESERVE



5422
National Cash Register With Cart and Telephones
\$800 - \$1,000 OFFERED WITHOUT RESERVE



5423
Drive-In Movie Speakers
\$150 - \$200 OFFERED WITHOUT RESERVE



5424
Coca-Cola Framed Ads
\$150 - \$200 OFFERED WITHOUT RESERVE



5425
License Plates
\$200 - \$300 OFFERED WITHOUT RESERVE



5426
Speed Queen Model No. DW6032 Washer and Wringer
\$200 - \$300 OFFERED WITHOUT RESERVE



5427
Starboard and Port Lamps
\$150 - \$250 OFFERED WITHOUT RESERVE



5429
Fire Alarms
\$150 - \$200 OFFERED WITHOUT RESERVE



5430
Service Center Dioramas
\$75 - \$100 OFFERED WITHOUT RESERVE



5431
Vintage Cameras
 \$75 - \$100 OFFERED WITHOUT RESERVE



5432
Children's Push-Pull Cart
 \$75 - \$100 OFFERED WITHOUT RESERVE



5433
Wood Soda and Beer Crates
 \$75 - \$100 OFFERED WITHOUT RESERVE



5434
Children's Rocking Horses
 \$100 - \$150 OFFERED WITHOUT RESERVE



5435
Pair of Charlie Chaplin Lamps
 \$75 - \$100 OFFERED WITHOUT RESERVE



5436
Pocket Cigarette Holders
 \$100 - \$150 OFFERED WITHOUT RESERVE



5438
Auburn, Cord, and Duesenberg Artwork
 \$100 - \$150 OFFERED WITHOUT RESERVE



5439
Movie Artwork
 \$175 - \$200 OFFERED WITHOUT RESERVE



5440
Decorative Bar Top Items
 \$400 - \$500 OFFERED WITHOUT RESERVE



5441
Budweiser Collectibles
 \$250 - \$300 OFFERED WITHOUT RESERVE



5442
Miller Collectibles
 \$250 - \$300 OFFERED WITHOUT RESERVE



5443
Pabst Collectibles
 \$100 - \$150 OFFERED WITHOUT RESERVE



5444
Alcohol and Tobacco Collectibles
 \$150 - \$200 OFFERED WITHOUT RESERVE



5445
Soda Fountain Syrup Dispensers
 \$100 - \$150 OFFERED WITHOUT RESERVE



5446
Interstate Batteries Signs
 \$100 - \$150 OFFERED WITHOUT RESERVE



5447
Radio Flyer Scooter
 \$50 - \$75 OFFERED WITHOUT RESERVE



5448
Mobilgas Globe
 \$800 - \$1,000 OFFERED WITHOUT RESERVE



5449
Vintage Automobile Fire Extinguishers
 \$100 - \$150 OFFERED WITHOUT RESERVE



5450
Vintage Ashtrays
 \$100 - \$150 OFFERED WITHOUT RESERVE



5451
Emblems, License Plate Toppers, and Radiator Caps
 \$150 - \$200 OFFERED WITHOUT RESERVE



5452
American Marque Mascots
 \$350 - \$400 OFFERED WITHOUT RESERVE



5453
Grille Badges
 \$150 - \$200 OFFERED WITHOUT RESERVE



6000
Texaco 'Black-T' Motor Oil "Free Crankcase Service" Porcelain Sign
 \$1,000 - \$1,500 OFFERED WITHOUT RESERVE



6001
Exide Batteries Metal Sign
 \$400 - \$700 OFFERED WITHOUT RESERVE



6002
"HyVis "F" for Fords" Metal Sign
 \$1,000 - \$1,500 OFFERED WITHOUT RESERVE



6003
HyVis "Buy Oil By Your Mileage" Metal Sign
 \$400 - \$700 OFFERED WITHOUT RESERVE



6004
Imperial Garage Automobiles with Car Metal Sign
 \$400 - \$700 OFFERED WITHOUT RESERVE



6005
"Pennzoil Safe Lubrication" with Red Bell Porcelain Sign
 \$750 - \$1,250 OFFERED WITHOUT RESERVE



6006
'White Rose' Porcelain Sign
 \$200 - \$400 OFFERED WITHOUT RESERVE



6007
"Time to Retire? (Buy Fisk)" with Boy Logo Cardboard Poster
 \$750 - \$1,500 OFFERED WITHOUT RESERVE



6008
"Change to Quaker State Winter Oil" with Car Cloth Banner
 \$500 - \$900 OFFERED WITHOUT RESERVE



6009
"Change to Quaker State Winter Oil" with Lady Cloth Banner
 \$500 - \$800 OFFERED WITHOUT RESERVE



6010
"Change to Quaker State Cold Test Motor Oil" Cloth Banner
 \$400 - \$600 OFFERED WITHOUT RESERVE



6011
"Sunoco Mercury Made Motor Oil" Cloth Banner
 \$400 - \$600 OFFERED WITHOUT RESERVE



6012
"Naco Cork Gaskets for Fords" Metal Display Rack Easel Back
 \$300 - \$600 OFFERED WITHOUT RESERVE



6013
NOS "Amalie Pennsylvania Motor Oil" Curb Sign
 \$600 - \$1,000 OFFERED WITHOUT RESERVE



6014
Ford Large Oval Neon Porcelain Sign
 \$12,500 - \$17,500 OFFERED WITHOUT RESERVE



6015
Ford Oval Neon Porcelain Sign
 \$3,000 - \$5,000 OFFERED WITHOUT RESERVE



6016
Ford Service Neon Arrow Porcelain Sign
 \$7,000 - \$12,000 OFFERED WITHOUT RESERVE



6017
Chevrolet in Bowtie Neon Porcelain Sign
 \$4,000 - \$6,000 OFFERED WITHOUT RESERVE



6018
"Buick Valve in Head" Neon Porcelain Sign
\$4,000 - \$6,000 OFFERED WITHOUT RESERVE



6019
"Buick Valve in Head Authorized Service" Neon Porcelain Sign
\$5,000 - \$7,000 OFFERED WITHOUT RESERVE



6020
Shell Embossed Neon Porcelain Sign
\$5,000 - \$7,000 OFFERED WITHOUT RESERVE



6021
Tokheim No. 850 Clockface Restored Gas Pump
\$3,000 - \$5,000 OFFERED WITHOUT RESERVE



6022
Bowser Restored Curb Gas Pump
\$3,000 - \$5,000 OFFERED WITHOUT RESERVE



6023
"Polly Shoes" Porcelain Neon Sign
\$1,500 - \$2,500 OFFERED WITHOUT RESERVE



6024
Falstaff 'Beer' Logo Neon Porcelain Sign with Privilege Panel Bottoms
\$3,500 - \$5,500 OFFERED WITHOUT RESERVE



6025
Hamm's Beer Neon Porcelain Sign
\$2,500 - \$4,500 OFFERED WITHOUT RESERVE



6026
Kerr McGee 'Gas' Lighted Plastic Sign
\$300 - \$500 OFFERED WITHOUT RESERVE



6027
Dick's Beer Neon Porcelain Sign
\$1,500 - \$3,000 OFFERED WITHOUT RESERVE



6028
Case with Old Abe Logo Vertical Neon Porcelain Sign
\$7,500 - \$12,500 OFFERED WITHOUT RESERVE



6029
A-1 Pilsner Beer Neon Porcelain Sign
\$1,500 - \$2,500 OFFERED WITHOUT RESERVE



6030
BEER Neon Porcelain Sign
\$1,000 - \$2,000 OFFERED WITHOUT RESERVE



6031
GMC Large Lighted Plastic Letters
\$400 - \$800 OFFERED WITHOUT RESERVE



6032
Bowtie 'Chevrolet' Lighted Logo Sign
\$300 - \$600 OFFERED WITHOUT RESERVE



6033
Red Spot Paints Neon Added Tin Sign
\$1,000 - \$2,000 OFFERED WITHOUT RESERVE



6034
Pontiac Neon Sign
\$4,000 - \$6,000 OFFERED WITHOUT RESERVE



6035
Texaco I.D. Neon Sign
\$4,000 - \$5,000 OFFERED WITHOUT RESERVE



6036
Greyhound Bus with Logo Lighted Plastic Sign
\$400 - \$600 OFFERED WITHOUT RESERVE



6037
Ford Service Plastic Lighted Arrow Sign
\$800 - \$1,200 OFFERED WITHOUT RESERVE



6038
**Pittsburg Paints Embossed
 Lighted Plastic Sign**
 \$400 - \$700 OFFERED WITHOUT RESERVE



6039
**EFM Automatic Heat Neuman Oil &
 Coal Plastic Lighted Sign**
 \$300 - \$500 OFFERED WITHOUT RESERVE



6040
**GM-Chevrolet Showroom Accessories
 Parts Display Case with Lights c. 1960**
 \$800 - \$1,200 OFFERED WITHOUT RESERVE

THE MEURER COLLECTION



6041
Buick Authorized Service Double-Sided Sign
 \$12,000 - \$15,000 OFFERED WITHOUT RESERVE



6042
Wooden Indian
 \$500 - \$600 OFFERED WITHOUT RESERVE



6043

Chicago Motor Car Club Bonded Service Station Double-Sided Porcelain Sign

\$500 - \$700 OFFERED WITHOUT RESERVE



6044

Ford Neons

\$1,000 - \$1,200 OFFERED WITHOUT RESERVE



6045

Ford Double-Sided Porcelain Neon Sign

\$8,000 - \$12,000 OFFERED WITHOUT RESERVE

6046

Firestone Vertical Tin Sign

\$400 - \$600 OFFERED WITHOUT RESERVE



6047

Packard Neon Sign

\$15,000 - \$20,000 OFFERED WITHOUT RESERVE



6049

**Packard Double-Sided
Vertical Neon Sign**

\$20,000 - \$25,000 OFFERED WITHOUT RESERVE

6048

Oldsmobile Service Sign

\$3,000 - \$5,000 OFFERED WITHOUT RESERVE



6050

Pegasus Single-Sided Porcelain Sign

\$4,000 - \$5,000 OFFERED WITHOUT RESERVE

6051

**Studebaker Single-Sided
Vertical Neon Sign**

\$10,000 - \$12,000 OFFERED WITHOUT RESERVE



6052

Lincoln Mark III Double-Sided Lighted Sign

\$1,500 - \$2,000 OFFERED WITHOUT RESERVE



6053

Texaco Sign

\$4,000 - \$5,000 OFFERED WITHOUT RESERVE



6054

Kaiser Frazer Double-Sided Neon Sign

\$6,000 - \$8,000 OFFERED WITHOUT RESERVE



6055

Pair of Firestone Large Plastic Signs

\$1,800 - \$2,200 OFFERED WITHOUT RESERVE



6056

Pontiac Double-Sided Neon Sign

\$12,000 - \$15,000 OFFERED WITHOUT RESERVE



6057

DeSoto Plymouth Double-Sided Neon Sign

\$6,000 - \$8,000 OFFERED WITHOUT RESERVE



6058

Chevrolet Bow Tie Single-Sided Neon Sign

\$10,000 - \$12,000 OFFERED WITHOUT RESERVE



6059
Champion Spark Plug Service Tester and Metal Sign
 \$250 - \$350 OFFERED WITHOUT RESERVE



6060
Oldsmobile GM Hydra-Matic Drive Double-Sided Neon Sign
 \$10,000 - \$12,000 OFFERED WITHOUT RESERVE



6061
Perry Auto Sales Buick Double-Sided Neon Sign
 \$6,000 - \$8,000 OFFERED WITHOUT RESERVE



6062
Artex Motor Oil Pump
 \$150 - \$200 OFFERED WITHOUT RESERVE



6063
Coca-Cola, 7UP, and Hamilton Coolers
 \$300 - \$400 OFFERED WITHOUT RESERVE



6064
Coca-Cola Coolers
 \$400 - \$600 OFFERED WITHOUT RESERVE



6065
Pepsi-Cola and Coca-Cola Coolers
 \$300 - \$500 OFFERED WITHOUT RESERVE



6066
Northern Electric Company Limited Telephone Switchboard
 \$1,000 - \$1,200 OFFERED WITHOUT RESERVE



6067
Telephone Booth
 \$1,000 - \$1,200 OFFERED WITHOUT RESERVE



6068
Vintage Scales
 \$400 - \$600 OFFERED WITHOUT RESERVE



6069
Vintage Fans
 \$500 - \$700 OFFERED WITHOUT RESERVE



6070
Mills Novelty Co. Slot Machine
 \$1,400 - \$1,600 OFFERED WITHOUT RESERVE



6071
National Cash Register
 \$800 - \$1,000 OFFERED WITHOUT RESERVE



6072
Public Telephone Signs
 \$100 - \$150 OFFERED WITHOUT RESERVE



6073
Enterprise Manufacturing Co. Coffee Mill
 \$700 - \$900 OFFERED WITHOUT RESERVE



6074
Victrola Record Player
 \$350 - \$450 OFFERED WITHOUT RESERVE



6075
Crosley Model No. 59 Vertical Radio
 \$400 - \$500 OFFERED WITHOUT RESERVE



6076
Sparton Table Radio
 \$300 - \$400 OFFERED WITHOUT RESERVE



6077
Art Deco Coin-Operated Chairside Radio
 \$300 - \$400 OFFERED WITHOUT RESERVE



6078
WesTinghouse Coca-Cola Coin-Operated Vending Machine
 \$1,400 - \$1,600 OFFERED WITHOUT RESERVE



6079
Dad's Root Beer Keg With Taps
 \$350 - \$450 OFFERED WITHOUT RESERVE



6080
Philco Table Radio
 \$350 - \$450 OFFERED WITHOUT RESERVE



6081
Candy Vending Machine
 \$250 - \$350 OFFERED WITHOUT RESERVE



6082
Popcorn Machine
 \$200 - \$300 OFFERED WITHOUT RESERVE



6083
Small Candy Dispensers
 \$150 - \$200 OFFERED WITHOUT RESERVE



6084
Waltling Penny Scale
 \$700 - \$900 OFFERED WITHOUT RESERVE



6085
Waltling Penny Scale
 \$700 - \$900 OFFERED WITHOUT RESERVE



6086
Koken Barber Chair
 \$700 - \$900 OFFERED WITHOUT RESERVE



6087
Zenith Radio and Record Player
 \$75 - \$125 OFFERED WITHOUT RESERVE



6088
Children's Barber Chair
 \$800 - \$1,000 OFFERED WITHOUT RESERVE



6089
Schwinn Bicycle with Air Pump
 \$150 - \$250 OFFERED WITHOUT RESERVE



6090
Firestone Whitewall Tire With Display Stand
 \$150 - \$250 OFFERED WITHOUT RESERVE



6091
Oil Dispenser Cart
 \$350 - \$500 OFFERED WITHOUT RESERVE



6092
Gilbarco Air Pump
 \$800 - \$1,000 OFFERED WITHOUT RESERVE



6093
Huffman Quart Bottles With Carrier
 \$300 - \$400 OFFERED WITHOUT RESERVE



6094
Mobile "AF" Filpruf Bottles With Carrier and Rack
 \$2,000 - \$3,000 OFFERED WITHOUT RESERVE



6095
Wayne Company Visible Gas Pump
 \$800 - \$1,200 OFFERED WITHOUT RESERVE



6096
United Motors Service Neon Porcelain Sign and Small Lighted Sign
 \$8,000 - \$10,000 OFFERED WITHOUT RESERVE



6097
"Cities Service Koolmotor" Fry Visible Gas Pump, Model 17
 \$2,800 - \$3,200 OFFERED WITHOUT RESERVE



6098
"Hudson Regular" Tokheim Clock Face Gas Pump
 \$2,500 - \$3,000 OFFERED WITHOUT RESERVE



6099
"Red Crown Gasolene" Correct Measure 10H Pipe Organ Visible Gas Pump
 \$2,500 - \$3,500 OFFERED WITHOUT RESERVE



6100
"Johnson Gasolene" Fry Visible Gas Pump, Model 70
 \$1,500 - \$2,000 OFFERED WITHOUT RESERVE



6101
Mobiloil Double-Sided Curb Sign
 \$2,000 - \$3,000 OFFERED WITHOUT RESERVE



6102
"Shell" G&B Gas Pump, Model 66
 \$3,500 - \$4,000 OFFERED WITHOUT RESERVE



6103
Wurlitzer Multi-Selection Jukebox
 \$1,000 - \$1,500 OFFERED WITHOUT RESERVE



6104
Bell System Telephone Booth
 \$800 - \$1,200 OFFERED WITHOUT RESERVE



6105
Seeburg 100 Select-O-Matic Jukebox
 \$1,500 - \$2,000 OFFERED WITHOUT RESERVE



6106
Vendo F39B7 Coca-Cola Machine
 \$1,000 - \$1,500 OFFERED WITHOUT RESERVE



6107
Budweiser World Champion Clydesdale Team Chandelier
 \$150 - \$200 OFFERED WITHOUT RESERVE



6108
General Electric Custom Pinstriped Fridge
 \$800 - \$1,200 OFFERED WITHOUT RESERVE



6109
Coca-Cola Chandelier
 \$350 - \$400 OFFERED WITHOUT RESERVE



6110
Ice Cream Fountain with Neons and Ephemera
 \$2,000 - \$3,000 OFFERED WITHOUT RESERVE



6111
Westinghouse Coca-Cola Vending Machine
 \$700 - \$900 OFFERED WITHOUT RESERVE



6112
Seeburg 100 Select-O-Matic Jukebox
 \$1,500 - \$2,000 OFFERED WITHOUT RESERVE



6113
Vendo Coca-Cola Bottle Vending Machine, Model XF39D
 \$1,000 - \$1,500 OFFERED WITHOUT RESERVE



6114
Wayne Gas Pump, Model 80
 \$1,800 - \$2,500 OFFERED WITHOUT RESERVE



6115
Drink Coca-Cola / Slow School Zone Double-Sided Sign with Stand
 \$2,000 - \$3,000 OFFERED WITHOUT RESERVE



6116
Reproduction Conoco Branded Gasoline Pump
 \$1,800 - \$2,500 OFFERED WITHOUT RESERVE



6117
Fry Visible Gas Pump, Model 17
 \$2,000 - \$2,500 OFFERED WITHOUT RESERVE



6118
Packard Neon Clocks
 \$2,000 - \$3,000 OFFERED WITHOUT RESERVE



6119
Bowser Visible Gas Pump
\$3,000 - \$5,000 OFFERED WITHOUT RESERVE



6120
Fry Visible Gas Pump, Model 17
\$2,000 - \$2,500 OFFERED WITHOUT RESERVE



6121
Socony Air-Craft Mobile Fueler
\$350 - \$450 OFFERED WITHOUT RESERVE



6122
Replica Gilmore Branded Gas Pump
\$400 - \$600 OFFERED WITHOUT RESERVE



6123
Bennett Gasoline Pump, Model 541
\$2,800 - \$3,200 OFFERED WITHOUT RESERVE



6124
**Correct Measure 10H
Pipe Organ Visible Gas Pump**
\$3,000 - \$5,000 OFFERED WITHOUT RESERVE



6125
Fry Visible Gas Pump, Model 17
\$2,000 - \$3,000 OFFERED WITHOUT RESERVE



6126
Texaco Visible Gas Pump
\$1,500 - \$2,500 OFFERED WITHOUT RESERVE



6127
**Correct Measure 10H
Pipe Organ Visible Gas Pump**
\$3,000 - \$5,000 OFFERED WITHOUT RESERVE



6128
Bowser Visible Gas Pump
\$3,000 - \$5,000 OFFERED WITHOUT RESERVE



6129
Barbershop Pole
\$300 - \$500 OFFERED WITHOUT RESERVE



6130
Kendall GT-1 Racing Oil Clock
\$500 - \$700 OFFERED WITHOUT RESERVE



6131
**Amalie Pennsylvania Motor Oil
Double-Sided Sign with Stand**
\$4,500 - \$6,500 OFFERED WITHOUT RESERVE



6132
Cadillac Double-Sided Neon Sign
\$12,000 - \$15,000 OFFERED WITHOUT RESERVE



6133
**Flottop Airplane Propeller with
Minneapolis Eight-Day Clock**
\$400 - \$600 OFFERED WITHOUT RESERVE



6134
Eco Tirelator
\$600 - \$700 OFFERED WITHOUT RESERVE



6135
Phillips Pump and Tank Co. Dispenser
\$200 - \$300 OFFERED WITHOUT RESERVE



6136
Westinghouse Coca-Cola Cooler
\$700 - \$900 OFFERED WITHOUT RESERVE



6137
**Drink Coca-Cola Fountain Service with
Spickets Multi-Piece Porcelain Sign**
\$8,000 - \$12,000 OFFERED WITHOUT RESERVE



6138
**Wayne Ten Gallon Visible Gas
Pump with Original Paint**
\$2,000 - \$3,000 OFFERED WITHOUT RESERVE



6139
Ten Gallon Visible Gas Pump with Original Paint
 \$2,000 - \$4,000 OFFERED WITHOUT RESERVE



6140
Large Buick Vertical Neon Porcelain Sign
 \$10,000 - \$15,000 OFFERED WITHOUT RESERVE



7001
A Ferrari Reference Logbook Featuring "Ferrari in Camera" by Geoffrey Goddard
 \$1,000 - \$1,200 OFFERED WITHOUT RESERVE



7002
A Collection of Racecar Driver Autobiographies Porsche Reference Titles and Racetrack Books
 \$250 - \$300 OFFERED WITHOUT RESERVE



7003
A Collection of American Auto Reference Titles
 \$100 - \$150 OFFERED WITHOUT RESERVE



7004
Collectible Reference Titles
 \$75 - \$100 OFFERED WITHOUT RESERVE



7005
Coca-Cola with Bottle Button Porcelain Sign
 \$800 - \$1,200 OFFERED WITHOUT RESERVE



7006
Bentley 'Auto' with Logo Sign
 \$400 - \$600 OFFERED WITHOUT RESERVE



7007
Richard's Cleaners Double-Sided Lighted Sign
 \$2,000 - \$3,000 OFFERED WITHOUT RESERVE



7008
Street Sign with Embossed "Stop" Concrete Base
 \$1,000 - \$1,500 OFFERED WITHOUT RESERVE



7009
Sunbeam Bread Tin Sign
 \$1,000 - \$2,000 OFFERED WITHOUT RESERVE



7010
Top Value Stamps Metal Sign
 \$300 - \$500 OFFERED WITHOUT RESERVE



7011
Clement "Les Cycles" Bicycle Poster
 \$750 - \$1,200 OFFERED WITHOUT RESERVE



7012
Antar-Gel with Oil Can and Car Graphics Poster
 \$500 - \$900 OFFERED WITHOUT RESERVE



7013
1955 Schwenninger Race Poster
 \$300 - \$600 OFFERED WITHOUT RESERVE



7014
1953 Gran Premio d' Italia Race Poster
 \$300 - \$600 OFFERED WITHOUT RESERVE



7015
Silver 427 Cobra Oil on Canvas by Maher
 \$750 - \$1,500 OFFERED WITHOUT RESERVE



7016
"Schumacher's Day" F-1 Ferrari 2004 Oil on Canvas by Neale
 \$400 - \$700 OFFERED WITHOUT RESERVE



7017
Mobil No. 10 F-1 Race Car Oil on Canvas by Vic
 \$200 - \$400 OFFERED WITHOUT RESERVE



7018
"Surfcity" Woodye and Pier Oil on Canvas by Dan J. Johnson
 \$400 - \$700 OFFERED WITHOUT RESERVE



7019
"Aloha" Woodie at the Beach
 by Dan J. Johnson
 \$300 - \$500 OFFERED WITHOUT RESERVE



7020
"Dog Patch" Woodie at the Beach with Surfers Oil on Canvas by Dan J. Johnson
 \$400 - \$700 OFFERED WITHOUT RESERVE



7021
F-1 Race Car Oil Paintings
 \$300 - \$600 OFFERED WITHOUT RESERVE



7022
Early Ferrari Race Cars Oil on Canvas by Hortino
 \$1,000 - \$2,000 OFFERED WITHOUT RESERVE



7023
Continental Auto Racing Award "Safety in Auto Racing Award" c. 1960
 \$800 - \$1,200 OFFERED WITHOUT RESERVE



7024
"NASCAR Auto Assn. Emergency Service" Metal Sign
 \$1,000 - \$2,000 OFFERED WITHOUT RESERVE



7025
"Smooth Tires Spell Danger Street & Highway Safety Campaign" Banner
 \$750 - \$1,500 OFFERED WITHOUT RESERVE



7028
B-17 Bomber Engine Table
 \$8,000 - \$10,000 OFFERED WITHOUT RESERVE



7029
Shell Gas Double-Lens Globe
 \$3,000 - \$3,500 OFFERED WITHOUT RESERVE



7030
Lebanon Valley Stock Car Races Cardboard Poster
 \$150 - \$300 OFFERED WITHOUT RESERVE



7031
Stock Car Races Cardboard Posters
 \$150 - \$300 OFFERED WITHOUT RESERVE



7032
Steve McQueen Movie Poster "Le Mans" and "The Hunter"
 \$150 - \$300 OFFERED WITHOUT RESERVE



7033
1989 "1000 Miglia" Race Poster with Ferrari
 \$150 - \$300 OFFERED WITHOUT RESERVE



7034
1964 "Int. ADAC-Bergpreis Freiburg-Schauinsland" Race Poster
 \$150 - \$300 OFFERED WITHOUT RESERVE



7035
1966 Motodrom Race Poster
 \$150 - \$300 OFFERED WITHOUT RESERVE



7036
1980 and 1985 Porsche Race Posters
 \$150 - \$300 OFFERED WITHOUT RESERVE



7036A
Original 1975 Ferrari Poster from Automobile Quarterly Magazine
 \$400 - \$700 OFFERED WITHOUT RESERVE



7037
"Piorelli Radial Tires" with Race Car Plastic Lighted Clock
 \$400 - \$700 OFFERED WITHOUT RESERVE



7038
Bennett Model No. 3366 Computing Gas Pump
 \$500 - \$900 OFFERED WITHOUT RESERVE



7039
Unusual Turn Signal Traffic Light
 \$200 - \$400 OFFERED WITHOUT RESERVE



7040
Large Four-Way Traffic Stop Light with Built in Flashers
 \$400 - \$600 OFFERED WITHOUT RESERVE



7041
1957 Chevrolet Talking Hamilton Scale
 \$2,000 - \$3,000 OFFERED WITHOUT RESERVE



7042
Bowser Counter-Top Lubster, Restored
 \$750 - \$1,500 OFFERED WITHOUT RESERVE



7043
Kendall Neon Tin Sign
 \$2,000 - \$3,000 OFFERED WITHOUT RESERVE



7044
Camel GT Cigarettes Sign with IMSA Race Car
 \$400 - \$800 OFFERED WITHOUT RESERVE



7044A
Route 66 New Neon Metal Sign
 \$600 - \$1,200 OFFERED WITHOUT RESERVE



7045
NASCAR Winston Cup Series with Dale Earnhardt No. 3 Wrangles Car
 \$500 - \$900 OFFERED WITHOUT RESERVE



7046
Al Unser Jr. and Valvoline Indy Car No. 5 Painting by Finnell
 \$300 - \$600 OFFERED WITHOUT RESERVE



7047
Black Cat Fire Crackers Original Poster
 \$200 - \$400 OFFERED WITHOUT RESERVE



7048
1967 BOAC International 500 Poster
 \$200 - \$400 OFFERED WITHOUT RESERVE



7049
1935 MCF (Motorcycle Club of France) Poster by Geo Ham
 \$400 - \$800 OFFERED WITHOUT RESERVE



7050
Hudson-Essex "Free!" February Car Give Away Original Poster
 \$200 - \$400 OFFERED WITHOUT RESERVE



7051
Socovel Motorcycle Poster
 \$400 - \$800 OFFERED WITHOUT RESERVE



7052
1955 Vedette Versailles with Car and Couple Poster
 \$400 - \$800 OFFERED WITHOUT RESERVE



7053
1969 Porsche Weltmeister Poster
 \$300 - \$600 OFFERED WITHOUT RESERVE



7054
1960 Porsche Weltmeister World Champion Poster
 \$300 - \$600 OFFERED WITHOUT RESERVE



7055
Ferrari F-40 "Double Your Pleasure" by Harvey
 \$500 - \$900 OFFERED WITHOUT RESERVE



7056
1968 Porsche 1.2.3. Daytona 24 Hour Race Poster
 \$200 - \$400 OFFERED WITHOUT RESERVE



7057
Porsche "Tourist Delivery Program" Poster
 \$200 - \$400 OFFERED WITHOUT RESERVE



7058
Phone Booth
 \$800 - \$1,200 OFFERED WITHOUT RESERVE



7059
Coca-Cola Cooler Chest
\$1,000 - \$1,500 OFFERED WITHOUT RESERVE



7060
Phone Booth
\$800 - \$1,200 OFFERED WITHOUT RESERVE



7061
Coin-Operated Herbie The Love Bug Kiddie Ride
\$4,000 - \$6,000 OFFERED WITHOUT RESERVE



7062
Coin Operated Sinclair Dino Kiddie Ride
\$4,000 - \$6,000 OFFERED WITHOUT RESERVE



7063
"Ludwig The Beatles" Drum Cover
\$100 - \$200 OFFERED WITHOUT RESERVE



7064
John Deere 2-Legged Logo Metal Sign
\$500 - \$900 OFFERED WITHOUT RESERVE



7065
U.S. Navy Practice Boom MK 15 Mod. 4 Water-Sand Fill
\$600 - \$1,000 OFFERED WITHOUT RESERVE



7066
Reproduction M&S Gas Pump with Hand Painted Mobil Station and Mustang
\$1,500 - \$2,500 OFFERED WITHOUT RESERVE



7067
"Jaguar Sales & Service" with Logo Porcelain Sign
\$6,000 - \$12,000 OFFERED WITHOUT RESERVE



7068
Abstract Indy Car Oil Painting on Canvas
\$200 - \$400 OFFERED WITHOUT RESERVE



7069
Royal Crown Nehi Cooler Chest
\$500 - \$700 OFFERED WITHOUT RESERVE



7070
7Up Cooler Chest
\$500 - \$700 OFFERED WITHOUT RESERVE



7071
Gulf Neon Porcelain Sign
\$5,000 - \$6,000 OFFERED WITHOUT RESERVE



7072
Original Watkins Glen Grand Prix Catalogs and Others
\$150 - \$300 OFFERED WITHOUT RESERVE



7073
Original Ford Mustang Cobra GT 350/500 Shelby Postcards
\$100 - \$200 OFFERED WITHOUT RESERVE



7074
All Original Steelcraft Hudson Sport Roadster Peddle Car
\$500 - \$1,000 OFFERED WITHOUT RESERVE



7075
Garton "Station" Wagon Wooden Peddle Car
\$500 - \$1,000 OFFERED WITHOUT RESERVE



7076
Large Goodyear Auto Service Center Metal Sign
\$500 - \$1,000 OFFERED WITHOUT RESERVE

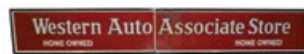

7077
Western Auto Associate Store Large Two-Piece Porcelain Sign
\$1,000 - \$2,000 OFFERED WITHOUT RESERVE



7078
Goodyear Dealer Large Three-Piece Porcelain Sign
\$1,000 - \$2,000 OFFERED WITHOUT RESERVE



7079
GM AC Delco Master Technician Service Center Metal Sign
 \$300 - \$600 OFFERED WITHOUT RESERVE

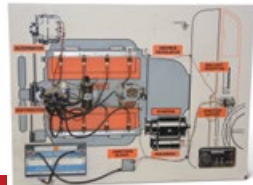

7080
Three-Dimensional Teaching Aid of Motor
 \$400 - \$700 OFFERED WITHOUT RESERVE



7081
Broadway Checkered Cab Stage Prop
 \$1,000 - \$1,500 OFFERED WITHOUT RESERVE



7082
Rambler "Safe Buy" Lighted Sign
 \$2,500 - \$3,500 OFFERED WITHOUT RESERVE



7083
National Cash Register
 \$1,000 - \$1,500 OFFERED WITHOUT RESERVE



7084
Nice Outside Metal Pay Telephone Booth
 \$1,000 - \$1,500 OFFERED WITHOUT RESERVE



7085
Fantasy "Oilzum Motor Oils and Lubricants" Sign
 \$600 - \$1,000 OFFERED WITHOUT RESERVE



7086
Good Gulf and Gulf tane Porcelain Pump Signs
 \$150 - \$250 OFFERED WITHOUT RESERVE



7087
Gulf No-Nox Gulf tane Porcelain Pump Signs
 \$150 - \$250 OFFERED WITHOUT RESERVE



7091
AAA Emergency Service Neon Porcelain Sign
 \$2,500 - \$3,500 OFFERED WITHOUT RESERVE



7092
Firestone Neon Tin Sign
 \$3,000 - \$4,000 OFFERED WITHOUT RESERVE



7093
Valvoline Neon Tin Sign
 \$3,000 - \$4,000 OFFERED WITHOUT RESERVE



7094
Coca-Cola Neon Tin Sign
 \$2,500 - \$3,500 OFFERED WITHOUT RESERVE



7095
Remington Tires Neon Tin Sign
 \$2,500 - \$3,500 OFFERED WITHOUT RESERVE



7097
Quaker State Neon Tin Sign
 \$2,500 - \$3,500 OFFERED WITHOUT RESERVE



7098
Pennzoil Neon Tin Sign
 \$2,000 - \$3,000 OFFERED WITHOUT RESERVE



7099
1/4 Scale Automobile Teaching Aid by Heinrich Vogel
 \$1,000 - \$2,000 OFFERED WITHOUT RESERVE



7100
Ford Merkur Lighted Plastic Sign
 \$200 - \$400 OFFERED WITHOUT RESERVE



7101
1/4 Scale WWII German Me 109 Airplane Model
 \$4,000 - \$6,000 OFFERED WITHOUT RESERVE



7102
WWII Tribute Memphis Belle and Rosie the Riveter Art Piece
 \$400 - \$800 OFFERED WITHOUT RESERVE



7103
NOS Mobil 1 Sidewalk Metal Sign
 \$200 - \$400 OFFERED WITHOUT RESERVE



8001
Four 22" Asanti Wheels
 \$400 - \$600 OFFERED WITHOUT RESERVE



8002
Four 14" Vintage 1967-1976 Pontiac Firebird Wheels
 \$400 - \$600 OFFERED WITHOUT RESERVE



8003
Porsche 915 Racing Transmission Rebuilt for 1970-1984 911
 \$400 - \$600 OFFERED WITHOUT RESERVE



8004
Acme Beer "Ask for Acme in Cans" Sign
 \$100 - \$200 OFFERED WITHOUT RESERVE



8005
LaSalle Head Lights
 \$600 - \$1,000 OFFERED WITHOUT RESERVE



8006
Fram and Borg Warner Tune-Up Parts Cabinets
 \$200 - \$300 OFFERED WITHOUT RESERVE



8010
Aresco Four-Post Drive-On Lift
 \$1,200 - \$1,500 OFFERED WITHOUT RESERVE



8007
Sun 1120 Electronic Engine Tester
 \$400 - \$600 OFFERED WITHOUT RESERVE



8008
Backyard Buddy Four-Post Drive-On Automotive Lift
 \$1,200 - \$1,500 OFFERED WITHOUT RESERVE



8009
Four-Post Drive-On Lift
 \$1,200 - \$1,500 OFFERED WITHOUT RESERVE



8011
Aresco Four-Post Drive-On Lift
 \$1,200 - \$1,500 OFFERED WITHOUT RESERVE



8013
Visubalancer Tire Balancer
 \$300 - \$400 OFFERED WITHOUT RESERVE



8014
Kelsey-Hayes Cadillac 15-inch Wheels
 \$200 - \$300 OFFERED WITHOUT RESERVE



8015
Crestline Water Pump
 \$75 - \$100 OFFERED WITHOUT RESERVE



8016
Cadillac Flathead V-8
 \$3,500 - \$5,000 OFFERED WITHOUT RESERVE



8017
Vintage Tools
 \$400 - \$600 OFFERED WITHOUT RESERVE



8018
Ashtray With Knob
 \$75 - \$100 OFFERED WITHOUT RESERVE



8019
1933-1934 17-in. Wire Wheels With Tires
 \$100 - \$150 OFFERED WITHOUT RESERVE



8020
Ashtray with Handle
 \$75 - \$100 OFFERED WITHOUT RESERVE



8021
1933-1934 17-in. Wire Wheels With Tires
 \$75 - \$100 OFFERED WITHOUT RESERVE



8023
Ford V8 Artillery Style Wheels
 \$100 - \$150 OFFERED WITHOUT RESERVE



8024
Allen Test Engine Analyzer
 \$300 - \$400 OFFERED WITHOUT RESERVE



8025
Allen Engine Analyzer
 \$300 - \$400 OFFERED WITHOUT RESERVE



8026
Sun Inspector
 \$300 - \$400 OFFERED WITHOUT RESERVE



8028
Sun Distributor Tester
 \$300 - \$400 OFFERED WITHOUT RESERVE



8029
**Expert Engine Service
 Double-Sided Sign with Stand**
 \$400 - \$600 OFFERED WITHOUT RESERVE



8030
**Rebuilt Chrysler 727 Torqueflite
 Automatic Transmission**
 \$800 - \$1,000 OFFERED WITHOUT RESERVE



8031
**Pair of "Cadillac Factory Recommended
 Reconditioning Supplies" Storage Cabinets**
 \$1,000 - \$2,000 OFFERED WITHOUT RESERVE



8032
Rearview Mirrors With Clocks
 \$600 - \$800 OFFERED WITHOUT RESERVE



8033
Packard Straight Eight Block
 \$800 - \$1,000 OFFERED WITHOUT RESERVE



8035
**1932-1938 Ford V-8 Flathead
 21-Stub with Aluminum Heads**
 \$800 - \$1,000 OFFERED WITHOUT RESERVE



8036
Pair of Packard Straight Eight Engines
 \$1,000 - \$1,200 OFFERED WITHOUT RESERVE



8037
1935 Ford Wire Wheels
 \$200 - \$300 OFFERED WITHOUT RESERVE



8038
**Six American-Arrow 17x4 Wire
 Wheels; Fits 900 Series Packard**
 \$8000 - \$12,000 OFFERED WITHOUT RESERVE



8039
1962 Thunderbird Convertible Trunk Crated
 \$400 - \$600 OFFERED WITHOUT RESERVE



8040
Buick Riviera Wheels with Tires
 \$400 - \$600 OFFERED WITHOUT RESERVE



8041
Pair of Industrial Carts
 \$400 - \$600 OFFERED WITHOUT RESERVE



8042
Pair of Fleetline Travel-Tested Luggage
 \$75 - \$100 OFFERED WITHOUT RESERVE



8043

Pair of Hartman Luggage
\$75 - \$100 OFFERED WITHOUT RESERVE



8044

Pair of Luggage
\$75 - \$100 OFFERED WITHOUT RESERVE



8045

Pair of Hartman Pattern Luggage
\$75 - \$100 OFFERED WITHOUT RESERVE



8046

Five-Piece Hartman Pattern Luggage
\$75 - \$100 OFFERED WITHOUT RESERVE



8047

Cadillac Eldorado Brougham Vanity Set
\$2,500 - \$3,500 OFFERED WITHOUT RESERVE



8048

1967 Cadillac Eldorado Bumper
\$3,000 - \$4,000 OFFERED WITHOUT RESERVE



8049

1936 Ford Grille
\$300 - \$500 OFFERED WITHOUT RESERVE



8050

1933 Ford Grille
\$400 - \$600 OFFERED WITHOUT RESERVE



8051

1934 Ford Grille
\$400 - \$600 OFFERED WITHOUT RESERVE



8052

Buick Riviera Wheels
\$200 - \$300 OFFERED WITHOUT RESERVE



8053

Hudson Wheels
\$250 - \$350 OFFERED WITHOUT RESERVE



8050

Cadillac Wheels
\$400 - \$500 OFFERED WITHOUT RESERVE



8055

Wire Wheels
\$75 - \$100 OFFERED WITHOUT RESERVE



8056

Wire Wheels
\$75 - \$100 OFFERED WITHOUT RESERVE



8057

1935 Packard Artillery-Style Wheels
\$400 - \$500 OFFERED WITHOUT RESERVE



8058

Packard Caribbean Wheels and Tires
\$400 - \$500 OFFERED WITHOUT RESERVE



8059

Edelbrock Heads for Ford Flathead V-8
\$200 - \$300 OFFERED WITHOUT RESERVE



8060

Pair of Buell Trombone Horns
\$200 - \$300 OFFERED WITHOUT RESERVE



8061

Precision Tool Boards
\$100 - \$150 OFFERED WITHOUT RESERVE



8062

Pair of Cadillac Batwing Air Cleaners
\$1,000 - \$2,000 OFFERED WITHOUT RESERVE



8063
Cadillac Eldorado Taillights
 \$1,000 - \$2,000 OFFERED WITHOUT RESERVE



8064
1935-1936 Ford Dashboard
 \$100 - \$150 OFFERED WITHOUT RESERVE



8065
Ford V-8 Front and Rear Bumpers
 \$100 - \$150 OFFERED WITHOUT RESERVE



8066
1937-1939 Ford Dashboard
 \$100 - \$150 OFFERED WITHOUT RESERVE



8067
Vintage Ford Radios
 \$100 - \$150 OFFERED WITHOUT RESERVE



8068
1934 Ford Hood
 \$300 - \$400 OFFERED WITHOUT RESERVE



8069
Ford Banjo Steering Wheels With Horn Buttons
 \$300 - \$400 OFFERED WITHOUT RESERVE



8070
Ford V-8 Hubcaps
 \$75 - \$100 OFFERED WITHOUT RESERVE



8071
Spare Tire Wheel Covers
 \$100 - \$200 OFFERED WITHOUT RESERVE



8072
Packard Twelve Intake Manifold and Oil Pan
 \$200 - \$300 OFFERED WITHOUT RESERVE



8073
Steering Wheels
 \$250 - \$300 OFFERED WITHOUT RESERVE



8074
Vintage Radios
 \$100 - \$150 OFFERED WITHOUT RESERVE



8075
Gauges and Interior Accessories
 \$350 - \$400 OFFERED WITHOUT RESERVE



8076
Weidenhoff Test Equipment
 \$300 - \$400 OFFERED WITHOUT RESERVE



8077
Cadillac Salesmen's Sample Books
 \$300 - \$400 OFFERED WITHOUT RESERVE



8078
GM Salesmen's Samples and Duco Dulux Color Sample Books
 \$100 - \$150 OFFERED WITHOUT RESERVE



8079
Picnic Baskets
 \$100 - \$150 OFFERED WITHOUT RESERVE



8080
Law Requires 500 ft. Between Trucks Single-Sided Porcelain Sign
 \$200 - \$300 OFFERED WITHOUT RESERVE



8081
Car Record Players
 \$400 - \$500 OFFERED WITHOUT RESERVE



8082
Vintage Fog Lights
 \$250 - \$300 OFFERED WITHOUT RESERVE



8083
Cadillac and Oldsmobile Wheel Covers
\$350 - \$400 OFFERED WITHOUT RESERVE



8084
1973-1975 Plymouth Wheel Covers
\$200 - \$300 OFFERED WITHOUT RESERVE



8085
Pair of PA Tone Horns
\$100 - \$150 OFFERED WITHOUT RESERVE



8086
Ford and Lincoln Wheel Covers
\$100 - \$150 OFFERED WITHOUT RESERVE



8087
SS Wheel Covers
\$100 - \$150 OFFERED WITHOUT RESERVE



8088
Packard Hub Caps
\$200 - \$300 OFFERED WITHOUT RESERVE



8089
Ford Deluxe Hub Caps
\$150 - \$200 OFFERED WITHOUT RESERVE



8090
Cadillac 'Sombbrero' Wheel Covers
\$150 - \$200 OFFERED WITHOUT RESERVE



8091
Auto Compasses
\$75 - \$150 OFFERED WITHOUT RESERVE



8092
Headlights and Horns
\$150 - \$200 OFFERED WITHOUT RESERVE



8093
Assorted Vintage Parts
\$150 - \$250 OFFERED WITHOUT RESERVE



8094
Car Interior Accessories
\$150 - \$250 OFFERED WITHOUT RESERVE



8095
Sideview Mirrors
\$150 - \$250 OFFERED WITHOUT RESERVE



8096
Ashtray With Clock
\$75 - \$150 OFFERED WITHOUT RESERVE



8097
Vintage Car Heaters
\$100 - \$150 OFFERED WITHOUT RESERVE



8098
Metal Tartan Picnic Sets
\$75 - \$100 OFFERED WITHOUT RESERVE



8099
1949-1953 Ford Flathead V-8 8BA Engine and Transmission
\$1,000 - \$1,200 OFFERED WITHOUT RESERVE

29 AUGUST-1 SEPTEMBER 2019 **FALL**
AUBURN AUCTION PARK

AUBURN

AUCTION • CAR CORRAL • SWAP MEET

Thursday

| 29 August 2019

| Cars 2:00 p.m.

STILL ACCEPTING CONSIGNMENTS



Lot 1053: 1964 Cadillac Series 62

1999 BMW 740iL

\$6,000 - \$8,000

OFFERED WITHOUT RESERVE

282 hp 4.4-liter V-8;
automatic transmission

Finished in Oxford Green
Metallic over tan interior

Luxurious 'iL' long wheel base model

Includes power 'moon roof,' dual zone
climate control, power seats, and
electronic steering wheel adjustment

One of the most luxurious
cars of the late 1990s

1049



1970 Triumph 650

\$6,000 - \$8,000

OFFERED WITHOUT RESERVE

650-cc parallel-twin

Finished in dark green and silver

Large capacity fuel tank for touring

Features Pertronix ignition

Recently underwent
carburetor overhaul

1050



1964 Cadillac Series 62 Convertible

**1053**

\$20,000 - \$30,000
OFFERED WITHOUT RESERVE

340 hp 429 cu. in. V-8;
automatic transmission

Finished in attractive Firemist Blue

Features white convertible top
with zip-out rear window

Fitted with air conditioning

Power steering and brakes

1965 Buick Riviera

**1056**

\$30,000 - \$40,000

401 cu. in. 'Wild Cat' V-8;
automatic transmission

Finished in Arctic White
over black interior

Features new water pump,
alternator, and battery

Options include telescopic steering
wheel and Sonomatic radio

Power windows and door locks

Sits on wide whitewall radial tires

1979 Pontiac Firebird Trans Am

\$25,000 - \$30,000

6.6-liter V-8; automatic transmission

Presented in black over white vinyl

Equipped with factory air conditioning;
power steering and brakes

Rides on Snowflake wheels with
BFGoodrich Radial T/A tires

1061



2005 Cadillac XLR

\$18,000 - \$22,000

OFFERED WITHOUT RESERVE

320 hp, 4.6-liter Northstar V-8

Automatic transmission

Power seats, window,
steering and brakes

Retractable hardtop

Brake rotors and wheel
bearings recently replaced

1080





Lot 2040: 1955 Cadillac Eldorado Convertible

29 AUGUST-1 SEPTEMBER 2019
AUBURN AUCTION PARK

FALL

AUBURN

AUCTION • CAR CORRAL • SWAP MEET

Friday

| 30 August 2019

| Cars 11:00 a.m.





2001

1971 Dnepr KMZ MV-750

\$7,000 - \$10,000 OFFERED WITHOUT RESERVE



2006

1988 Cadillac Brougham

\$11,000 - \$15,000



2011

1931 Chevrolet Deluxe Five-Window Sedan

\$15,000 - \$20,000



2013

1963 Studebaker Avanti

\$40,000 - \$50,000



2014

1956 Ford Fairlane

\$20,000 - \$25,000



2017

1956 Ford Eight-Passenger Country Sedan

\$35,000 - \$45,000 OFFERED WITHOUT RESERVE



2021

1973 Chevrolet Camaro Z28

\$22,000 - \$28,000 OFFERED WITHOUT RESERVE



2022

1985 Excalibur

\$30,000 - \$40,000



2024

1966 Chevrolet El Camino SS

\$30,000 - \$40,000



2025

1978 Ford F-150 Pickup

\$20,000 - \$30,000



2026

1931 Chevrolet Independence Phaeton

\$28,000 - \$32,000



2027

1967 Chevrolet Nova Restomod

\$80,000 - \$90,000



2030

1972 Ford Mustang Convertible

\$12,000 - \$18,000 OFFERED WITHOUT RESERVE



2032

1964 Ford Thunderbird Convertible

\$25,000 - \$30,000



2033

2007 Ford Shelby GT500

\$45,000 - \$55,000

500 hp, 5.4-liter supercharged V-8 engine

Six-speed manual transmission

Only 10.4 actual miles; never titled and still on MSO

One of only 28 Torch Red stripe-delete cars built for 2007

Still in the wrapper, retains its original plastic coverings

Includes factory manuals and window sticker



2034

1937 American Austin Model 142

\$15,000 - \$20,000



2035

1962 Studebaker GT Hawk

\$28,000 - \$32,000



2036

1958 Nash Metropolitan 1500 Series II Convertible

\$20,000 - \$27,000 OFFERED WITHOUT RESERVE

1,498-cc inline four-cylinder engine; three-speed manual transmission

Finished in Autumn Yellow and Frost White

Beneficiary of a concours restoration; extensive documentation included

Interior is completed in black and white houndstooth

Upgraded with four-wheel-disc brakes and modern spin-on filter

Accompanied by BMIHT Certificate, workshop manual, parts manual, original oil filter assembly, original oil bath air cleaner, original parking brake linkage, three spare wheels, and custom made protective seat covers



2037

1988 Cadillac Brougham

\$11,000 - \$15,000

140 hp, 307 cu. in V-8 engine

Turbo-Hydramatic automatic transmission

Optioned with premier formal vinyl roof

Equipped with AM/FM radio with cassette player

Power door locks, windows, steering, and brakes



2039

1956 Oldsmobile Holiday Two-Door

\$30,000 - \$40,000

Powered by Oldsmobile's famous Rocket V-8

Believed to be an original example; odometer displays less than 13,000 miles

Equipped with power seat, windows, and steering

Features dual sideview mirrors and fender skirts

Rides on wide whitewall tires; factory wheel covers

Original tires included with sale



2040

1955 Cadillac Eldorado Convertible

\$70,000 - \$80,000

325 hp, 365 cu. in. V-8 engine; automatic transmission

Older restoration, presents beautifully today

Power seat, windows, steering, and brakes

Two-tone interior features clock and radio

Equipped with GM's Autronic Eye

Well maintained and recently serviced

One of 3,950 Eldorado Convertibles produced for 1955

1954 Chevrolet Corvette



2041

\$60,000 - \$70,000

235 cu. in. Blue Flame inline six-cylinder engine

Powerglide two-speed automatic transmission

Finished in classic Polo white over red interior with beige soft top

Featured with removable side windows with storage bags, tonneau cover, and trunk mat

One of just 3,640 built

1986 Pontiac Firebird Trans Am by Auto-Form



2042

\$12,000 - \$16,000

OFFERED WITHOUT RESERVE

305 cu. in. V-8; four-speed automatic transmission with overdrive

Striking, GM sanctioned custom built convertible by Auto-Form of Elkhart, Indiana

Power windows, locks, steering, and brakes

Fitted with factory air conditioning

Features AM/FM stereo

Perfect car for Radwood

1968 Chevrolet Corvette Stingray Coupe

\$30,000 - \$35,000

2043

350 hp, 327 cu. in. V-8; owner states the car is numbers matching

Muncie four-speed manual transmission; Posi-traction rear end

Restored in 2008; photos and documentation included

Finished in Rally Red with Red leather interior

Equipped with power windows, steering, and brakes

Extensively optioned with tilt steering column, AM/FM radio, speed indicator, rear defroster, and t-tops with leather cases



1934 Covered Wagon Camping Trailer

\$42,000 - \$48,000

2044

America's first mass-market travel trailer

Authentic restoration

Magnificent preserved interior

Fully detailed with period accessories





THE ED MEURER COLLECTION
90+ MOTOR CARS OFFERED ALMOST ENTIRELY WITHOUT RESERVE





LOTS 2045 - 2142



In 1958 Ed Meurer, Jr. bought his first old car, a 1936 Ford Cabriolet. The paint was cracked, the upholstery was worn, but the car drove just fine. Over the next four years Ed restored the car back to concours condition. Having been bitten by the "old car" bug, he set about collecting other Fords of the 1930s, inspired by the cars he had owned while living in Southern California as a teenager.

Later on he would expand his reach to Cadillacs, Buicks, Chryslers and especially Packards. As the years turned into decades, his love of the hobby expanded to Nash, Studebaker and Jaguar. Like rings on a tree, his maturing tastes in fine automobiles came to include "personality" cars with interesting histories.

In 2001 he built an extension to his publishing company in Metro Detroit, large enough to house his entire collection of antique vehicles and memorabilia, inadvertently becoming the fifth largest private auto museum in Michigan. By 2015 his collection had expanded to 119 vehicles and 4,000 sq. ft. of gas pumps, neon signs and other antique collectables. Well known in car club circles, Ed's garage became a welcome visit for his semi-annual Open House events and a must-see during the annual Woodward Dream Cruise. Dozens of car clubs and thousands of car club members have toured his garage to marvel at his eclectic car collection. As he has said many times, "I never bought an old car as an investment, only because I liked the way it looked." It is RM Sotheby's pleasure to present the outstanding Meurer Collection at auction and look forward to celebrating its wonderful motor cars with you, our fellow enthusiasts.



2045

1994 J.B. Enterprises Dual-Axle Trailer

\$1,500 - \$3,000 OFFERED WITHOUT RESERVE

Dual-axle configuration; side-mounted spare

Equipped with 12,000-lb Badland Winch

Features power trailer jack



2046

1998 Classic MFG Dual-Axle Enclosed Trailer

\$3,000 - \$6,000 OFFERED WITHOUT RESERVE

Dual-axle configuration

Features power trailer jack

Side door entry on both sides



2047

1936 Mullins Trailer

\$4,000 - \$6,000 OFFERED WITHOUT RESERVE

Single-axle utility trailer

Rides on whitewall tires with Ford Deluxe hub caps

Accompanied by documentation, club information, and a dealer sign



2048

1971 Buick Riviera

\$10,000 - \$15,000 OFFERED WITHOUT RESERVE

455 cu. in. V-8; TH400 automatic transmission

Finished in Pearl Beige

Air conditioning; power windows, steering, and brakes

Fitted with knock-off spinner wheels

Interior features clock and AM/FM radio



2049

1976 Cadillac Eldorado Convertible

\$10,000 - \$15,000 OFFERED WITHOUT RESERVE

V-8 engine; automatic transmission

Air conditioning; power door locks, windows, steering, and brakes

Stylish interior with wood trim by Fleetwood

Fitted with aftermarket Kenwood CD radio

Rides on thin whitewall tires; factory wheel covers



2050

1950 Hudson Commodore Eight Sedan

\$18,000 - \$24,000 OFFERED WITHOUT RESERVE

262 cu. in. inline six-cylinder engine

Manual transmission with Super-Matic Drive overdrive

Originally sold through Rodocker Motors of Indianapolis, Indiana

Mr. Meurer purchased from a model builder who loved Hudsons

Equipped with an external sun visor and dual sideview mirrors

Interior features a traffic light reflector, clock, radio, and heater



2051

1936 Ford Pickup

\$25,000 - \$35,000 OFFERED WITHOUT RESERVE

Flathead V-8; floor-shift manual transmission

Equipped with dual fog lights and dual side-mounted covered spares

Interior features include cabin heater and rearview mirror with clock

Sits on wide whitewall tires

Upgrades include modern alternator and electric fan



2052

1981 Cadillac Coupe DeVille

\$5,000 - \$8,000 OFFERED WITHOUT RESERVE

368 in. cu. fuel-injected V-8 engine; automatic transmission

Owned by the Meurer family from new

Full leather interior with wood trimmed dash

Air conditioning; power windows, door locks, steering and brakes

Fitted with radio and MPG Sentinel monitor

Accompanied by copy of Cadillac build sheet



2053

1941 Ford Custom

\$20,000 - \$25,000 OFFERED WITHOUT RESERVE

Built in the style of Barris

Carson-style removable hardtop

Powered by Oldsmobile J-2 V-8

Three-speed column-shift manual transmission

Two-tone interior features traffic light reflector, radio, and heater



2054

1965 Pontiac Tempest LeMans GTO Convertible

\$25,000 - \$35,000 OFFERED WITHOUT RESERVE

389 cu. in. Tri-Power V-8; automatic transmission

Equipped with air conditioning; power steering and brakes

Interior features bucket seats, console, accessory gauges, and aftermarket Sony radio

Rides on BFGoodrich Radial T/A tires



2055

1957 Mercury Commuter Station Wagon

\$25,000 - \$35,000 OFFERED WITHOUT RESERVE

Powered by Mercury's Turnpike Cruiser V-8 engine

Push-button automatic transmission

Air conditioning; power rear window, steering, and brakes

Wonderful color combination

All new sheet metal from the firewall back



2056

1960 Airstream Travel Trailer

\$15,000 - \$25,000 OFFERED WITHOUT RESERVE

Wonderful example of the iconic polished aluminum camper

Features a nice kitchen configuration

Single-axle configuration



2057

1978 Cadillac Eldorado Custom Biarritz Classic

\$10,000 - \$15,000 OFFERED WITHOUT RESERVE

180 hp, 425 cu. in. V-8; automatic transmission

Desirable final year of the full-sized Eldorado

Rare Eldorado Custom Biarritz Classic edition one of 2,000 produced

Finished in Arizona Beige with Demitasse Brown metallic

Custom leather interior is finished in dark saddle leather with light beige

Power seats, windows, steering and brakes

Fitted with air conditioning and climate control



2058

1941 Chrysler New Yorker Highlander

\$15,000 - \$20,000 OFFERED WITHOUT RESERVE

323 cu. in. Inline eight-cylinder engine

Chrysler Fluid-Drive three-speed manual transmission

Owned by longtime member of the Walter P. Chrysler Club who commissioned a no-expense spared restoration

Equipped with fog lights, dual sideview mirrors, dual spotlights, and sun visor

Features the distinctive Highlander interior with a clock, radio, and heater



2059

1948 Plymouth Coupe

\$12,000 - \$16,000 OFFERED WITHOUT RESERVE

Inline six-cylinder engine; column-shift manual transmission

Equipped with dual fog lights, dash-mounted clock, and driver-side spotlight

Features factory radio and aftermarket indicator switch

Rides on wide whitewall tires



2060

1937 Pierce-Arrow Model A Travelodge

\$35,000 - \$45,000 OFFERED WITHOUT RESERVE

Travelodge was the first trailer designed by an automobile company

Beautifully restored example; completed in the late 1970s

Believed to be one of 105 Model A Travelodges manufactured



2061

1977 Mercedes-Benz 450 SEL 6.9 Sedan

\$20,000 - \$30,000 OFFERED WITHOUT RESERVE

Highly desirable 6.9-liter V-8 engine; automatic transmission

First year of the extended wheelbase 6.9 in U.S. market

Featured with Mercedes-Benz Club of America and R.A.C. grille badging

Equipped with sunroof, climate control, and Blaupunkt AM/FM radio with cassette

Equipped with power windows, steering, and brakes

Mr. Meurer purchased from Doctor in Ann Arbor, MI



2062

1938 Ford Deluxe Convertible Coupe

\$25,000 - \$35,000 OFFERED WITHOUT RESERVE

Flathead V-8; floor-shift manual transmission

Equipped with dual fog lights and dual sideview mirrors

Interior features banjo steering wheel, radio, and glovebox clock

Sits on wide whitewall tires



2063

1960 Cadillac Eldorado Seville

\$40,000 - \$50,000 OFFERED WITHOUT RESERVE

390 cu. in. V-8 engine; automatic transmission

Dashboard plaque stating "Made especially for John O'Sullivan"

Beautiful older restoration; air suspension functioning

Correctly finished in Ebony with a white convertible top and interior

Equipped with air conditioning; power convertible top, steering, and brakes

Interior features Autronic Eye, clock, radio, and tissue dispenser

Accompanied by copy of Cadillac build sheet

One of 1,075 Eldorado Seviles produced for 1960



2064

1956 Chrysler 300B

\$35,000 - \$45,000 OFFERED WITHOUT RESERVE

340 bhp, 354 cu. in. V-8 engine

Push-button automatic transmission

Features a Gary Goers interior

Mr. Meurer had the car repainted

Equipped with clock, radio, and power windows

Wonderful example of Chrysler's letter car series

One of 1,102 produced for 1956



2065

1953 Packard Caribbean Convertible

\$35,000 - \$45,000 OFFERED WITHOUT RESERVE

Finished in cream over burgundy with a burgundy top

Mr. Meurer purchased from a couple in Erie, PA

Rides on wide whitewall tires mounted on wire wheels with factory hub caps

Fitted with aftermarket Sony radio with CD

One of 750 produced for 1953



2066

1936 Ford Deluxe Roadster

\$30,000 - \$40,000 OFFERED WITHOUT RESERVE

21-stud flathead V-8; three-speed manual transmission

Equipped with dual fog lights, dual sideview mirrors, wind wings, rumble seat, covered spare, luggage rack, and blue dot tail lights

Interior features banjo steering wheel, rearview mirror with clock, and factory radio



2067

1954 Buick Skylark Convertible

\$50,000 - \$70,000 OFFERED WITHOUT RESERVE

200 bhp, 322 cu. in. V-8 engine; automatic transmission

Power seat, windows, convertible top, steering, and brakes

Interior features clock and Selectronic radio

One of only 836 Skylarks produced for 1954



2068

1951 Mercury Station Wagon

\$40,000 - \$50,000 OFFERED WITHOUT RESERVE

Flathead V-8 engine; column-shift manual transmission

Equipped with Borg Warner electric overdrive

Finished in Kerry Blue with burgundy interior

Desirable example with three-rows of seating

Interior features clock and Hi Fidelity radio

Fitted with electric cooling fan

Rides on Diamond Back tires; rear-mounted spare

One of 3,812 Station Wagons produced for 1951



2069

1968 Jaguar E-Type Series 1 1/2 4.2-Litre Roadster

\$45,000 - \$55,000 OFFERED WITHOUT RESERVE

4.2-liter inline six-cylinder engine; dual Stromberg carburetors

Four-speed manual gearbox

Desirable green and tan color combination

Believed to be one of 657 LHD Series 1.5 Roadsters produced



2070

1938 Chrysler Custom Limousine

\$30,000 - \$40,000 OFFERED WITHOUT RESERVE

Inline eight-cylinder engine; manual transmission

Ordered new by Joseph P. Kennedy, father of President Kennedy

Used while in London from 1938-1940 while serving as Ambassador to Great Britain

Fitted with semaphore turn signals, dual sidemount covered spares, and fender skirts

Passenger compartment features silver plated trim, dual jump seats, glove compartments, vanities, floor heaters, intercom, and radio

Shown at Meadowbrook and the Concours d'Elegance of America at St. John's



2071

1956 Cadillac Series Sixty Special Fleetwood

\$25,000 - \$35,000 OFFERED WITHOUT RESERVE

365 cu. in. V-8 engine; automatic transmission

Finished in Dawn Gray over Camelot Gray

Equipped with air conditioning, Autronic Eye, clock, radio, power windows and steering

Rides on wide whitewall tires; gold sabre wheels

Accompanied by Cadillac build sheet



2072

1959 Jaguar Mark IX

\$20,000 - \$25,000 OFFERED WITHOUT RESERVE

220 hp 3.7-liter inline six-cylinder engine

Borg Warner three-speed automatic transmission

Exterior features dual fender-mounted mirrors, dual fog lights, and rear wheel spats

Interior is fitted with radio, wood dashboard, and desirable optional sunshine roof



2073

1969 Lincoln Continental Mark III

\$16,000 - \$22,000 OFFERED WITHOUT RESERVE

365 hp, 460 cu. in. V-8; automatic transmission

Finished in attractive Medium Blue over tan interior

Retractable headlight covers

Rides on thin whitewall tires

Air conditioning; power windows, steering, and brakes

Features AM/FM Stereo and desirable Autolamp function



2074

1962 Ford Thunderbird Convertible

\$18,000 - \$24,000 OFFERED WITHOUT RESERVE

390 cu. in. V-8 engine; automatic transmission

Finished in the beautiful 1962 Ford shade of Chestnut

Air conditioning; power seat, windows, steering, and brakes

Equipped with AM/FM radio

Accompanied by Sports Roadster boot cover

One of 8,417 convertibles produced for 1962



2075

1950 Nash Statesman Super Airflyte

\$20,000 - \$30,000 OFFERED WITHOUT RESERVE

Inline six-cylinder engine; three-speed manual transmission

Meticulously restored example

Wonderful two-tone color combination accented by beautiful brightwork

Equipped with driver sideview mirror, sun visor, and curb feelers

Interior features a clock and radio with rear speaker



2076

1987 Chevrolet El Camino SS

\$12,000 - \$16,000 OFFERED WITHOUT RESERVE

V-8 engine; Turbo Hydramatic automatic transmission

Fitted with aftermarket Pioneer radio with CD

Power windows, door locks, steering, and brakes

Equipped with black vinyl bed cover

Sits on BFGoodrich Radial T/A tires



2077

1960 Ford Thunderbird Coupe

\$15,000 - \$20,000 OFFERED WITHOUT RESERVE

V-8 engine; automatic transmission

Features a radio and Ford's Magic Air System

Equipped with continental kit

Rides on wide whitewall tires mounted on wire wheels



2078

1965 Lincoln Continental Convertible

\$20,000 - \$30,000 OFFERED WITHOUT RESERVE

V-8 engine; automatic transmission

Mr. Meurer purchased from Wes Myrick

Repainted in correct color; new convertible top

Recently fitted with a new interior kit

Features air conditioning, power windows, clock, and radio

Top mechanicals were completely gone through at cost of \$6,000

One of 3,356 convertibles produced for 1965



2079

1967 Cadillac Eldorado

\$20,000 - \$30,000 OFFERED WITHOUT RESERVE

429 cu. in. V-8; Turbo Hydramatic automatic transmission

Finished in Baroque Gold Metallic

Air conditioning; power steering and brakes

Interior features AM/FM radio, climate control, clock, power windows and locks



2080

1958 Edsel Citation Convertible

\$30,000 - \$40,000 OFFERED WITHOUT RESERVE

V-8 engine; push-button automatic transmission

Top-of-the-line Edsel model for 1958

Believed to be a mostly original car with a prior repaint

Finished in Jonquil Yellow with a white convertible top

Rides on wide whitewall tires; factory wheel covers

Shown at Meadowbrook Concours d'Elegance

One of 930 Citation Convertibles produced for 1958



2081

1957 Cadillac Series Sixty Special Fleetwood

\$30,000 - \$40,000 OFFERED WITHOUT RESERVE

365 cu. in. V-8 engine; automatic transmission

Equipped with air conditioning; power windows, steering, and brakes

Rides on thin whitewall tires mounted on silver sabre wheels

Factory price of over \$5,500 when new

Accompanied by Cadillac build sheet



2082

1937 Pierce-Arrow Model C Travelodge

\$10,000 - \$15,000 OFFERED WITHOUT RESERVE

Travelodge was the first trailer designed by an automobile company

Believed to be one of 74 Model C Travelodges manufactured

Lovely interior with kitchen, table, and couch

Rides on artillery-style wheels with Chevrolet hub caps



2083

1941 Packard Super Eight One Eighty Formal Sedan

\$30,000 - \$40,000 OFFERED WITHOUT RESERVE

Inline eight-cylinder engine

Three-speed manual transmission

Equipped with dual sidemounted covered spares

Museum displayed in Flint, Michigan

One of 930 produced for 1941 model year



2084

1955 Pontiac Star Chief Convertible

\$35,000 - \$45,000 OFFERED WITHOUT RESERVE

Powered by Pontiac's Strato Streak V-8; automatic transmission

Finished in Marietta Blue and Castle Grey

Rides on wide whitewall tires; factory wire wheel covers

Equipped with a power convertible top and steering

Interior features clock and radio



2085

1956 Chevrolet Bel Air Nomad

\$40,000 - \$50,000 OFFERED WITHOUT RESERVE

V-8 engine; automatic transmission

Finished in correct Matador Red over Dune Beige

Equipped with factory air conditioning and power steering

Interior features clock and radio

Rides on wide whitewall tires; factory wheel covers

Wonderful example of Chevrolet's iconic Nomad

One of 7,886 Bel Air Nomads produced for 1956



2086

1959 Chrysler 300E Convertible

\$60,000 - \$70,000

380 bhp, 413 cu. in. V-8 engine

Push-button automatic transmission

Equipped with power steering and brakes

Interior features clock and radio

Rides on wide whitewall tires; factory wheel covers

One of only 140 Convertibles produced for 1959



2087

1957 Oldsmobile Super 88 J-2 Convertible

\$40,000 - \$50,000 OFFERED WITHOUT RESERVE

Desirable J-2 V-8 engine with triple carburetor setup; automatic transmission

Equipped with dual spotlight rearview mirrors, power convertible top and steering

Interior features clock and Super De Luxe Wonder Bar radio

One of 7,128 Super 88 Convertibles produced for 1957



2088

1951 Hudson Hornet Convertible Brougham

\$35,000 - \$45,000 OFFERED WITHOUT RESERVE

308 cu. in. inline six-cylinder engine with Twin H-Power; automatic transmission

Finished in a lovely color combination

Equipped with external sun visor and dual sideview mirrors

Rides on wide whitewall tires mounted on wire wheels with factory wheel hubcaps

Interior features heater, radio, and power windows

One of approximately 500 built

1967 Jaguar E-Type Series 1 4.2-Litre 2+2

\$30,000 - \$40,000

OFFERED WITHOUT RESERVE

Powered by a 4.2-liter inline six-cylinder engine

Automatic transmission

Equipped with an aftermarket radio

Rides on knock-off wire wheels

Used in the movie *Freaky Deaky*

One of 601 LHD 4.2-Litre Series 1 2+2s

2089



1938 Buick Series 90 Limousine Right-Hand Drive

\$30,000 - \$40,000

OFFERED WITHOUT RESERVE

Buick Dynaflex straight eight-cylinder engine

Manual transmission

Older restoration; rare right-hand drive example

Originally ordered by the Maharajah of Jind in Haryana, India; imported to U.S. in the 1970's

Interior features clock and radio, divider window, rear jump seats and foot rests

2090



1931 Cadillac V-16 Seven-Passenger Imperial Sedan BY FLEETWOOD

\$120,000 - \$140,000

ENGINE NO. 702402



2091

Originally delivered to Mexico City; well-known history

Finished in original colors of Matisse Brown and Ravenswood Brown

Original engine, chassis, and body; accompanied by a copy of its factory build sheet

150-hp, 452-cu. in. OHV V-16 engine and three-speed manual transmission

Classic Car Club of America (CCCA) Full Classic

This V-16 Cadillac was originally delivered to Mexico City, per its original build sheet, finished in Matisse Brown and Ravenswood Brown with Wiese broadcloth upholstery, with metric instrumentation. In the mid-1930s it was acquired by Mauro Luna of Rio Blanca and put into storage, where it remained until 1960, when Señor Luna sold the Cadillac to American enthusiast Edward King. In an article in the July/August 1980 issue of Torque magazine, Mr. King noted that the Imperial sedan was complete and solid save for the addition of an electric fuel





pump and Rochester carburetors, and that he was able to drive it 333 km over two ranges of the Sierra Madre mountains into Mexico City – on one bank of cylinders and with a flat tire!

Mr. King returned to Michigan with the Cadillac in 1963, and in 1974 had a ground-up restoration performed in the original colors by Regal Restorations. Afterward the car remained in his ownership for several years, shown

in many CCCA Michigan Region activities. It was then acquired by John O'Sullivan, in whose ownership it was displayed at the ill-fated AutoWorld theme park in Flint, Michigan, before joining the current owner's renowned collection.

Well preserved and a wonderful CCCA CARavan or tour car, this elegant V-16 boasts a superb history that would be difficult to beat.



1958 Imperial Crown Limousine BY GHIA

\$80,000 - \$120,000



2092

One of just 31 examples built for 1958

Believed to have been used to chauffeur Queen Elizabeth II during her visit to Canada in 1959

Powered by a 392 cu. in. Hemi V-8 engine

Numerous luxury features

From the very beginning of the marque, Chrysler was known for producing big, powerful automobiles suitable for use as limousines. By the mid-1950s, however, the diminished demand for such a vehicle made it no longer feasible to produce them in-house. Chrysler, led by designer Virgil Exner, developed an all-new design and subcontracted the construction to Ghia of Turin, Italy. The results of this limited-production collaboration are some of the most desirable and luxurious American cars of the period, and the car offered here is certainly no exception.

To produce the Imperial Crown Limousines, Chrysler shipped to Ghia partially assembled Imperial hardtop coupes with 129-inch wheelbases and reinforced X-frames. The chassis and drivetrains were complete, and the bodies were fully assembled with appropriate bumpers and trim. Inside the stripped interiors were the rest of the parts needed to complete the car: four sedan doors, seat mounts, glass, a wired dashboard, dual A/C unit, leather for the upholstery, carpeting, station-wagon leaf springs for the rear, stiffer torsion bars for the





front, and a lengthened driveshaft. Ghia then performed extensive modifications to the chassis before fitting shapely, luxurious bodies and interiors, producing a trans-Atlantic collaboration that still seems new and fresh today.

In the end, however, even with subcontracting production out to Ghia, the Imperial limousine proved too costly, and production was halted after nine model years. In all, some 132 examples were produced, 31 of which were built for the 1958 model year, including the car offered here.

This Chrysler Imperial limo was hand-built by Ghia of Turin, Italy, in 1958. It is believed the Eaton family of Toronto, Ontario, purchased this car when new and that it was used primarily for chauffeuring Queen Elizabeth II during formal events on her 1959 trip to the Royal Fair, as she resided with the Eaton family during her stay. Two cars were said to have been ordered—this example and one with a unique plexiglass back window for use in parades. After the demise of the Eaton company, it is believed this car was stored at the family summer residence for many years. It was acquired by Ed Meurer in the 1990s and displayed at local shows. A wonderful example, it is believed to be one of very few of the 31 built that are still on the road.





2093

1958 Chevrolet Impala Convertible

\$55,000 - \$65,000 OFFERED WITHOUT RESERVE

V-8 engine; automatic transmission

Finished in Clay Coral with a white convertible top

Wonderful example with dual antennas, fender skirts, and continental kit

Equipped with Vintage Air conditioning

Power seat, windows, convertible top, and brakes

Interior features clock, radio, and tissue dispenser



2094

1937 Packard Super Eight 2/4-Passenger Coupe

\$50,000 - \$60,000 OFFERED WITHOUT RESERVE

135 bhp, 320 cu. in. straight eight-cylinder engine

Three-speed manual transmission

Originally sold through Ray B. Heim's Packard dealership of St. Joseph

Mr. Meurer purchased from Packard club member

Interior is equipped with a clock and Packard De Luxe Radio

Features rear-mounted trunk housing fitted luggage

Shown at Meadowbrook and the Concours of America at St. John's

Believed to be one of very few examples produced



2095

1946 Ford Super Deluxe Station Wagon

\$45,000 - \$60,000 OFFERED WITHOUT RESERVE

100 bhp, 239 cu. in. flathead V-8 engine

Three-speed manual transmission

Beautiful paint and woodwork

Exterior features fog lights, driver spotlight, driver mirror, and rear-mounted spare

Interior equipped with clock, radio, and heater

Well-known collector Blaine Jenkins sold the car to Mr. Meurer



2096

1936 Ford Three-Window Coupe

\$40,000 - \$50,000 OFFERED WITHOUT RESERVE

Flathead V-8 engine with dual-carburetor setup

Three-speed manual transmission

Equipped with fog lights, dual wipers, dual mirrors, fender skirts, and rear-mounted covered spare

Interior features radio and rearview mirror with clock

Converted to 12-volt



2097

1937 Cord 812 Custom Beverly

\$40,000 - \$50,000 OFFERED WITHOUT RESERVE

125 hp, 288.6 cu. in. V-8 engine

Four-speed pre-selector manual transmission

Mr. Meurer purchased from ACD club member

Older restoration; Classic Auto Restorations completed the interior

Interior features a Philco radio

Classic Car Club of America (CCCA) Full Classic

Former CCCA First Prize Winner



2098

1941 Buick Super Convertible Phaeton

\$35,000 - \$45,000 OFFERED WITHOUT RESERVE

248 cu. in. inline eight-cylinder engine

Three-speed column-shift manual transmission

Interior features a clock and Sonomatic radio

One of only 508 Super Convertible Phaetons produced for 1941



2099

1941 Cadillac Series 60S Fleetwood Sedan

\$25,000 - \$35,000 OFFERED WITHOUT RESERVE

Flathead V-8 engine; three-speed manual transmission

Equipped with dual sideview mirrors and fender skirts

Rides on wide whitewall tires; factory wheel covers

Nicely appointed interior features clock and radio

Accompanied by Cadillac build sheet



2100

1940 Ford Deluxe Coupe

\$25,000 - \$35,000 OFFERED WITHOUT RESERVE

Flathead V-8; column-shift manual transmission

Features AM Radio and cabin heater

Equipped with dual fog lights and dual sideview mirrors

Rides on wide whitewall tires



2101

1936 Ford Pickup

\$25,000 - \$35,000 OFFERED WITHOUT RESERVE

Flathead V-8 with Holley carburetor

Floor-shift manual transmission

Equipped with dual horns and dual sideview mirrors

Beautiful wood bed with wood stake sides

Interior features heater and aftermarket turn signal switch

Sits on wide whitewall tires



2102

1973 Ford Mustang Convertible

\$15,000 - \$20,000 OFFERED WITHOUT RESERVE

351 cu. in. V-8; three-speed automatic transmission

Features AM/FM radio and center console clock

Fitted with air conditioning

Power convertible top, steering, and brakes

Rides on thin whitewall tires



2103

1979 Cadillac Fleetwood Brougham d'Elegance Station Wagon by R.S. Harper Custom Coachbuilders

\$15,000 - \$20,000 OFFERED WITHOUT RESERVE

Built for Wilson-Crissman Detroit area Cadillac dealership to shuttle customers who brought cars in for service

Believed to be the only example produced with a sunroof

The owner of the dealership's mother liked it so much it became her personal car

Eventually sold to Top Hat John, a local appraiser and subsequently purchased by Ed Meurer

While part of the Meurer Collection the car received a new vinyl top

The perfect family classic, a unique head turner



2104

1953 Chevrolet Ambulance

\$18,000 - \$24,000 OFFERED WITHOUT RESERVE

Inline six-cylinder engine; column-shift three-speed manual transmission

Originally Sarnia, Ontario Volunteer Fire Department vehicle

Adorned with various exterior accessories such as sirens, emergency lights, and dual mirrors

Interior features CB and standard radio, stretcher, breathing apparatus, and first aid kit

Relivered for Coppock's Blaze Busters of Royal Oak, MI



2105

1936 Ford Cabriolet

\$20,000 - \$30,000 OFFERED WITHOUT RESERVE

Flathead V-8 with Stromberg carburetor

Three-speed manual transmission

Features rear-mounted luggage rack and covered spare

Interior features banjo steering wheel, radio, and driver's side wiper

Sits on wide whitewall tires



2106

1947 Packard Eight Custom Super Clipper Club Sedan

\$25,000 - \$35,000 OFFERED WITHOUT RESERVE

356 cu. in. inline eight-cylinder engine

Three-speed manual transmission

Beautiful example of one of the more streamlined Packard coupes

Classic Car Club of America (CCCA) Full Classic

One of 5,690 standard wheelbase Custom Super Clipper Eights produced for 1947



2107

1936 Chrysler Imperial Airflow Sedan

\$25,000 - \$35,000 OFFERED WITHOUT RESERVE

130 hp, 323.5 cu. in. L-head eight-cylinder engine

Three-speed manual transmission

Equipped with dual fog lights

Features radio and Mopar Deluxe cabin heater

Historically significant as America's first streamlined production car



2108

1952 Hudson Hornet Hollywood

\$25,000 - \$30,000 OFFERED WITHOUT RESERVE

145 hp 305 cu. in. 'Twin-H' powered straight-six

Automatic transmission

Equipped with clock, radio, and Hudson Weather Control heater

Features dual fog lights, sun visor, driver's side spotlight and sideview mirror

Rides on wide whitewall tires mounted on wire wheels



2109

1936 Ford Convertible Sedan

\$30,000 - \$40,000 OFFERED WITHOUT RESERVE

Finished in Bambalino Blue with optional Tacoma cream stripe; believed to be a special Easter color offered only in the month of April of 1936

Powered by a 21-stud flathead V-8 with Stromberg carburetor

Equipped with dual sideview mirrors, dual wipers, and blue dot tail lights

Interior features banjo steering wheel, glovebox door clock, factory radio and heater

Nicely restored example



2110

1936 Ford Deluxe Convertible

\$30,000 - \$40,000 OFFERED WITHOUT RESERVE

21-stud flathead V-8 with Stromberg 97 carburetor

Three-speed manual transmission

Rumble seat; luggage rack and covered rear-mounted spare

Interior features banjo steering wheel, factory radio, and rearview mirror with clock

Rides on wide whitewall tires; stainless hubcaps and trim rings



2111

1939 Ford Deluxe Convertible Sedan

\$30,000 - \$40,000 OFFERED WITHOUT RESERVE

24-stud flathead V-8 with Holley carburetor; electric fan

Restored by Herb Scranton of Edgartown, Ohio

Equipped with dual spotlights and dual sideview mirrors

Interior features banjo steering wheel, glovebox clock, and factory radio



2112

1959 Ford Galaxie Skyliner

\$30,000 - \$40,000 OFFERED WITHOUT RESERVE

V-8 engine; automatic transmission

Finished in a wonderful color combination

Equipped with power brakes

Interior features a clock, radio, and RCA Victor record player

One of 12,915 produced for 1959



2113

1958 Studebaker Golden Hawk

\$30,000 - \$40,000 OFFERED WITHOUT RESERVE

275 hp, 289 cu. in. 'Jet Stream' supercharged V-8

Automatic transmission

Equipped with air conditioning and modern alternator

Features dash-mounted clock and radio with cassette

Rides on wide whitewall tires; factory wheel covers

One of just 878 built in 1958



2114

1960 Buick Electra 225 Convertible

\$30,000 - \$40,000 OFFERED WITHOUT RESERVE

Powered by Buick's Wildcat V-8 engine

Automatic transmission

Power windows, seat, steering, and brakes

Equipped with Air conditioning

Two-tone interior features clock and radio

One of 6,746 produced for 1960



2115

1936 Cadillac Series 85 Seven-Passenger Touring Sedan

\$35,000 - \$45,000 OFFERED WITHOUT RESERVE

368 cu. in. V-12 engine; three-speed manual transmission

Nice older restoration

Classic Car Club of America (CCCA) Full Classic

Interior features clock and heater

Dual side mounted spares with metal covers

Trippe lights and dual sideview mirrors



2116

1933 Ford Roadster

\$40,000 - \$50,000 OFFERED WITHOUT RESERVE

Purchased by Mr. Meurer in 1959 from Dearborn Police Officer for \$900

Unrestored example at time of purchase; fully restored in 1972

Upgraded with 1948 flathead V-8 engine

Manual transmission featuring Lincoln Zephyr gears

Equipped with dual fog lights, dual horns, cowl lights, and driver's side wiper, and side mirror

Interior features a heater and clock in rearview mirror

Rumble seat and rear-mounted spare

Rides on whitewall tires mounted on wire wheels with factory hubcaps

1956 Packard Caribbean Convertible

\$40,000 - \$50,000
OFFERED WITHOUT RESERVE

CHASSIS NO. 56991003



2117

The rarest and most desirable year of the Caribbean
One of only 276 convertibles produced for 1956
Packard's last great automobile

For 1956 styling was modern and very attractive, with the top-line Packard Caribbean offering a distinctive tri-tone paint scheme, two-tone leather upholstery, and much more. The engine was enlarged to 374 cubic inches, producing 310 brake horsepower with dual four-barrel carburetors. Additionally, the cars now featured the new push-button Twin-Ultramatic transmission, a unique luxury feature for the 1950s. Although most 1956 updates were minor, one of the most attractive new features was a set of reversible seat cushions, leather on one side and elegant cloth on the other. Only 263 Caribbean hardtops

and 276 convertibles were built for 1956, making it the rarest year of the Caribbean convertible. Sadly, the 1956 Packard Caribbean would become the final convertible ever built by the company, as the Studebaker-Packard partnership for 1957 and 1958 simply produced coupes. Packard would sadly cease car production during the summer of 1958.

This 1956 Packard Caribbean Convertible is proudly offered from the Meurer Collection. Finished in the original color combination of Dover White, Shannon Green, and Corsican Black, it has a wonderful appearance



throughout. It rides on wide whitewall tires mounted on wire wheels with factory hubcaps. The interior features the unique dual-sided seat cushions, a brilliant idea that allowed owners to switch the look of their interior from a vinyl pattern to a cloth one. A beautiful textured anodized dashboard displays the instrumentation in easy view of the driver, additionally housing a clock and radio. The glovebox has a small plaque attached to it stating that this custom-built Caribbean was made specially for Annie K. Shunk.

The Caribbean has some of the best handling and finest road manners of any full-sized automobile of its era, and this example, as one of the improved 1956 models, is one of the rarer Packards. As part of the last run of convertibles built by the company, these cars remain highly sought after among collectors.



1961 Chrysler 300G Coupe

\$40,000 - \$50,000
OFFERED WITHOUT RESERVE



2118

375 hp, 413 cu. in. V-8 engine

Push-button automatic transmission

Equipped with air conditioning; power windows, steering, and brakes

Interior features bucket seats, full-length console, tachometer, clock and radio

Beautiful example of Chrysler's iconic letter car series

One of 1,280 Coupes built for 1961



1933 Packard Super Eight Club Sedan

\$40,000 - \$50,000
OFFERED WITHOUT RESERVE



2119

384 cu. in. straight eight-cylinder engine

Three-speed manual transmission

Originally delivered to Delavan, Wisconsin

Mr. Meurer purchased from former CCCA President David Schultz who had restored the car

Fitted with Trippe driving lights, fender lights, dual covered side-mounted spares, and rear-mounted trunk

Interior is equipped with a Packard Radio

Classic Car Club of America (CCCA) Full Classic



1958 Cadillac Eldorado Brougham

\$50,000 - \$60,000

CHASSIS NO. 58P013782

BODY NO. 471



2120

The ultimate and most expensive American automobile of its era

Sought-after 1958 model with the more powerful "Tri-Power" V-8

One of only 304 produced for 1958; highly desirable today

It is hard to imagine an American automaker today building a four-door sedan that would be priced higher than a new Ferrari or Rolls-Royce. The 1950s were a different time. Glitter was good, bigger was better, and too many accessories was just right in the age of chrome and neon. Ford had upped the ante with the introduction of its Continental Mark II, a two-door coupe so elite that the Blue Oval didn't even bother calling it a Lincoln. It was an era ripe for the ultimate Cadillac—a car heaped with everything that General Motors' engineering and styling gurus could throw at it.

Harley Earl's styling team contributed multiple new ideas, including four-door hardtop sedan bodywork with side windows that disappeared completely, frames and all; rear-hinged rear doors, which were a throwback to the 1930s; and a broad expanse of sparkling brushed stainless steel for the roof. Quad headlights were exclusive to the model and still illegal in most states. The engineering staff worked out a litany of power accessories so numerous that "power everything" wasn't just a convenient phrase, it was a reality. The trunk lid and rear doors not only opened with the push of a button, but they closed with one too, and the doors would lock automatically when the transmission was put in gear. A memory front seat was a first for a production car, as were the forged aluminum wheels. Naturally, there was air-conditioning.

All this high living came at a cost of \$13,974, which was twice the cost of the Eldorado Biarritz Convertible. In fact, one had to look long and hard to find a production car anywhere in the world that was as expensive as an Eldorado Brougham. Cadillac reportedly lost \$10,000 on every car built, which was why the original Eldorado Brougham lasted for only two years and only 704 examples were made.

The 1958 model offered here, number 471, was originally delivered to the Toledo, Ohio, sales district upon completion, finished in Nairobi Pearl with a Light Gray leather interior featuring Genuine Mouton carpet.



While early ownership is unknown, according to an online Cadillac database, the car was owned in the 1970s by noted Eldorado Brougham collector Larry Muckey of Muskegon, Michigan. Ed Meurer purchased the car in the late 1990s, proudly showing it over the years at Eyes on Design, the Milwaukee Concours, and St. John's.

Today the car is finished in a shade similar to the factory color Lake Placid Blue, accented beautifully with the stainless-steel roof. The car rides on whitewall tires mounted on steel wheels with factory wheel covers. The car is believed to ride on its original air suspension. It should be noted the system will require attention. When started, the car will level out and maintain a level stance; however, once the car is turned off, the system will deflate due to leaks. The Cadillac is equipped with air-conditioning, power steering, and brakes. The car appears to retain its original button-tufted Light Gray leather seats. Interior features include an Autronic Eye, clock, radio, and numerous power amenities. The Brougham is accompanied by a copy of its original build information from Cadillac.

The 1958 Eldorado Brougham retains the stunning glamour of a bygone age as only Cadillac could present it—with the most expensive automobile in the world.



1953 Buick Skylark Convertible



2121

\$50,000 - \$60,000

CHASSIS NO. 16973515

Top-of-the-line Buick from 1953

One of only 1,690 built

A Motorama car for the public

The Skylark was first displayed as a General Motors Motorama car in 1952, and it was essentially a factory-built "sport custom" that was based on the Roadmaster Convertible. The windshield was chopped four inches, while the beltline was cut down and notched at the rear fender line, and the rear-wheel cutouts were rounded and raised to match those in the front fenders. These were all techniques being used by California's customizers during the same period. The model was noteworthy for lacking Buick's trademark "ventiports" on the front fenders, and it rode on standard Kelsey-Hayes wire wheels.

A production version of the Skylark wowed the following year, as it was a limited-production offering that celebrated Buick's 50th anniversary. The production Skylark was noteworthy both for its beautiful design and as the car that debuted Buick's first modern overhead-





valve V-8, also called the “nailhead,” which could produce 188 horsepower. A \$5,000 price tag helped to keep sales to just 1,690 units.

While the Skylark name would continue as a limited-production model for 1954 and would reappear in Buick’s hierarchy for decades, the 1953 model is generally considered the most special and desirable by collectors. Along with the original Cadillac Eldorado and Oldsmobile Fiesta of the same year, it was a true example of Harley Earl’s “dream car design” that had been put on the street for the public to buy.

The 1953 Buick Skylark on offer has been refinished in a lovely color combination. It features dual sideview

mirrors, with a driver’s-side spotlight, and a continental kit with covered spare. It’s powered by Buick’s Fireball V-8 paired to an automatic transmission. The car rides on wide whitewall tires mounted on wire wheels. The Skylark is equipped with power windows, seat, antenna, convertible top, and steering. The interior is completed in a lovely dual tone which complements the car nicely. It features a compass, traffic light reflector, clock, and radio.

One of only 1,690 produced for 1953, this Skylark is a wonderful example of one of the most desirable Buicks of its decade, a Motorama car for the public.



1934 Packard Super 8 Coupe

**2122****\$90,000 - \$110,000**

VEHICLE NO. 758-1001

ENGINE NO. 753669

Beautifully presented example

Fascinating ownership history

One of just 1,920 Super 8 coupes built for 1934

Though Detroit is predominantly known as the home of Packard, by 1931 Packards were being assembled in Canada, with the goal of reducing export tariffs on cars that were to be sent to England and other European countries. In order to qualify, Canadian Packards were truly products of Canada. It is said that on Canadian-built examples, the tires were manufactured in Canada, as was the upholstery fabric and paint. The glass was made in England, but it was laminated in Canada. The radiator cores and headlamps were Canadian in origin, as were the carpeting, lacquer paint, and brakes. Other Canadian-sourced parts included front and rear springs, wheels, hub covers, mufflers, body hardware, and more. The engines

were assembled in Canada, both with locally sourced parts and parts supplied by the Detroit factory.

Though no 1934 Packard can be considered "common," Canadian-made Packards are significantly rarer than their American-made cousins. The example offered here is surely among the finest Canadian-built Super 8s in existence. Built on a Model 1104 chassis, this 758 Super 8 coupe features a 141½ in. wheelbase and is powered by a 385-cubic-inch straight-eight engine. The car is said to have a fascinating history, namely that it was purchased new in Canada by the nephew of an Italian dignitary. The nephew is said to have shipped the car to Italy, where it was enjoyed for a few years. With the outbreak of World



War II, the nephew reportedly had the car smuggled out of Italy and back to Canada. Upon arrival it was determined to be contraband by Canadian authorities, allegedly after being tipped off about the car by his uncle.

Now fully legal and properly licensed in the United States, the car presents beautifully and is in the long-term care and ownership of a prominent private collection. Offered in a stunning two-tone livery with cream

bodywork over black fenders, the car will be a surefire award winner after appropriate detailing. Fitted with a heater and accessory trunk, the car retains its Packard Motor Car Company of Canada badge, which is inscribed with the uniquely formulated Canadian dating method. It will surely make an impression on any CCCA CARavan or at any appropriate show.





2123

1941 Cadillac Convertible Sedan Deluxe

\$45,000 - \$55,000

Powered by flathead V-8 engine

Three-speed manual transmission

Beautifully restored example

Interior features clock and radio

Accompanied by Cadillac build sheet

Classic Car Club of America (CCCA) Full Classic



2124

1934 Ford Victoria

\$40,000 - \$50,000 OFFERED WITHOUT RESERVE

Flathead V-8 engine; manual transmission

Pop-out trunk for luggage; canvas covered when extended

Equipped with dual horns, cowl lights, dual wipers, and rearview mirror with clock

Diamond Back tires mounted on artillery-style wheels; rear-mounted spare

Third most expensive Ford V-8 offered in 1934



2125

1941 Cadillac Series 62 Convertible Coupe

\$35,000 - \$45,000 OFFERED WITHOUT RESERVE

346 cu. in. V-8 engine; column-shift three-speed manual transmission

\$5,000 engine rebuild, driven 20-miles since

Equipped with dual spotlights, dual sideview mirrors, and fender skirts

Rides on Coker wide whitewall tires mounted on Kelsey-Hayes-style wire wheels

Interior features clock, radio, and heater



2126

1955 Packard Caribbean Convertible

\$35,000 - \$45,000 OFFERED WITHOUT RESERVE

352 cu. in. V-8 engine; automatic transmission

Finished in White Jade over Rose Quartz and Onyx with a white soft-top

Fully restored by previous owner

Power windows, steering, and brakes

Interior features clock and radio

Shown at the 2015 Concours d'Elegance of America at St. John's

One of only 500 produced for 1955



2127

1949 Hudson Custom Eight Convertible Brougham

\$35,000 - \$40,000 OFFERED WITHOUT RESERVE

Inline six-cylinder engine

Three-speed column-shift manual transmission

Equipped with clock, radio, and heater

Top-of-the-line Commodore

Believed to be one of approximately 596 examples built for 1949



2128

1958 Chevrolet Bel Air Impala Hardtop Sport Coupe

\$30,000 - \$40,000 OFFERED WITHOUT RESERVE

V-8 engine; automatic transmission

Finished in Cashmere Blue

Equipped with fender skirts and continental kit

Interior features clock and radio with rear speaker

Rides on wide whitewall tires; factory wheel covers



2129

1953 Ford Convertible Custom

\$16,000 - \$22,000 OFFERED WITHOUT RESERVE

V-8 engine; automatic transmission

Working chopped convertible top

Power steering and brakes

Lowered; rides on wide whitewall tires

Features louvered hood and DeSoto front grille

Interior features traffic light reflector, tachometer, clock, and AM/FM radio with cassette



2130

1965 Buick Riviera GS

\$25,000 - \$35,000 OFFERED WITHOUT RESERVE

Powered by Buick's Super Wildcat V-8 engine

Console-shift automatic transmission

Air conditioning; power windows, steering, and brakes

Interior features bucket seats and AM/FM radio



2131

1936 Ford Five-Window Coupe

\$20,000 - \$30,000 OFFERED WITHOUT RESERVE

85 hp, 221 cu. in. flathead V-8

Three-speed manual transmission

Features rumble seat and dual exhaust

Fitted with covered spare

Utilizes modern alternator

Sits on wide whitewall tires



2132

1958 Lincoln Continental Mark III Convertible

\$30,000 - \$40,000 OFFERED WITHOUT RESERVE

430 cu. in. V-8 engine; automatic transmission

Stunning color combination

Power windows, seat, convertible top, steering, and brakes

Interior features Town and Country radio

One of 3,048 produced for 1958



2133

1935 Ford Roadster

\$30,000 - \$40,000 OFFERED WITHOUT RESERVE

21-stud flathead V-8 with Stromberg 97 carburetor; electric fan

Equipped with dual horns, dual sideview mirrors, wind wings, rumble seat, rear-mounted spare, and luggage rack

Interior features banjo steering wheel, rearview mirror with clock, and radio

Kelsey-Hayes-style wire wheels with factory hub caps



2134

1955 Ford Fairlane Crown Victoria

\$22,000 - \$28,000 OFFERED WITHOUT RESERVE

272 cu. in. V-8 engine; automatic transmission

Believed to be a mostly original example

Two-tone interior features clock and radio

Wide whitewall tires, wire wheel covers, and fender skirts



2135

1949 Ford Custom Deluxe Station Wagon

\$35,000 - \$45,000 OFFERED WITHOUT RESERVE

Flathead V-8 engine with dual carburetor setup and Offenhauser heads

Three-speed column-shift manual transmission

Borg Warner electric overdrive

Interior features clock, radio, and Magic Air vents

Desirable example with three rows of seating

Equipped with exterior sun visor and rear-mounted spare



2136

1950 Ford Crestliner

\$20,000 - \$25,000 OFFERED WITHOUT RESERVE

24-stud flathead V-8 engine

Three-speed column-shift manual transmission

Lovely presentation and color combination

Interior features clock and radio

Rides on Firestone wide whitewall tires; factory wheel covers



2137

1956 Continental Mark II

\$35,000 - \$45,000 OFFERED WITHOUT RESERVE

300 bhp, 368 cu. in. V-8 engine; automatic transmission

Believed to have been owned by Ford Executive Ernest R. Breech

Wonderful color combination

Equipped with numerous power amenities

\$10,000 price tag when new, one of the most expensive cars in 1956

One of 2,550 Mark IIs produced for 1956



2138

1957 Ford Fairlane Sunliner

\$30,000 - \$40,000 OFFERED WITHOUT RESERVE

Thunderbird Special V-8; automatic transmission

Equipped with power steering

Wonderful two-tone interior featuring compass, clock, and radio

Rides on wide whitewall tires; factory wheel covers

1931 Auburn Phaeton



2139

\$60,000 - \$70,000

ENGINE NO. 6U47233

Nicely presented in striking colors

Classic Car Club of America (CCCA) Full Classic

Ideal for touring

While the American automobile industry's development in its formative years had been guided by the inventor/engineer, its progress between the wars was shaped not so much by technicians as by entrepreneurs. One such was Auburn boss Errett Lobban Cord. When Cord joined Auburn as general manager in 1924, the company was in the doldrums, making more cars than it could sell and heading for bankruptcy. After some Cord-inspired restyling, Auburn sales picked up, and the stage was set for the creation of a glorious new automotive empire.

Nineteen thirty-one was a banner year for the company. It marked the first of the stylish sweeping-fender, long-hood Auburns, a design that was used through 1933. Of the many body styles put forward, the convertible phaeton sedan, priced at a quite reasonable \$1,345, was undoubtedly regarded as the top-of-the-line offering. The Auburn Phaetons featured exclusive options, including roll-up windows and removable center pillars for a tight seal with the top raised.

Offered here is a beautifully presented example of just such an Auburn. The car is nicely optioned with dual side-mounted spare wheels, an accessory trunk and rack, Pilot Ray lamps, and dual chrome horns and driving lamps. The interior is beautifully trimmed and nicely complements its exceptional maroon-and-champagne exterior finish, which is further accented by chrome bumpers, chrome spoke wheels with wide whitewall tires, beautifully restored factory-applied custom trim, and stately tan cloth convertible top. In addition to its good looks, this car is also said to run, shift, and drive with smoothness and a quiet not often associated with cars of this era. Its 98-horsepower inline eight-cylinder engine easily propels the car smoothly down the road and with surprisingly good acceleration.

The history of the car is known to the Auburn Cord Duesenberg Club, and it is said to have been restored some years ago by a father-son team of ACD members.

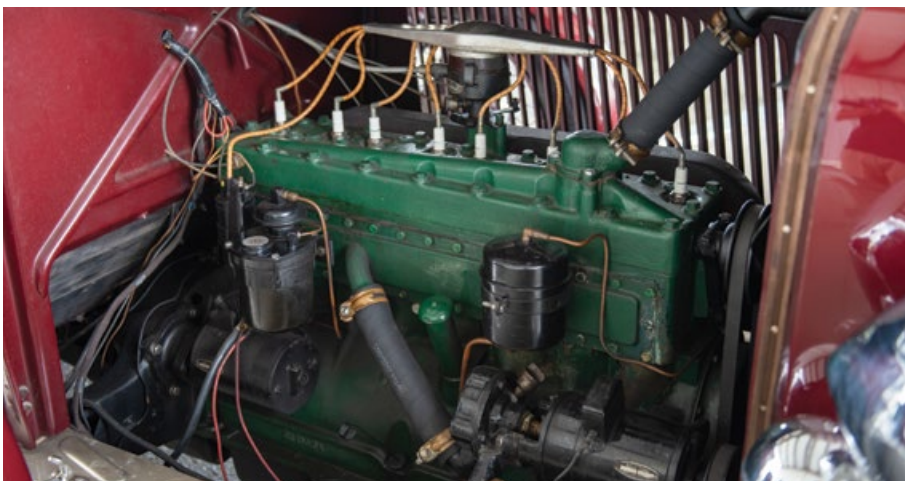



It then passed to the noted collector Gene Leadbetter before finding its way into the Meurer Collection, under whose care the car won Best in Show at the 2006 Bay Harbor Concours.

Because of the significance Auburns represent, all eight-cylinder examples are recognized as CCCA Full Classics and are eligible for all events held by the Classic Car Club of America. A fine driving example certain to impress on long CCCA CARavan tours, yet also appropriate for inclusion at any Concours d'Elegance, the Auburn is a supremely desirable addition to any discerning collection of fine Classic motor cars.



1953 Oldsmobile Ninety-Eight Fiesta



2140

\$80,000 - \$120,000

CHASSIS NO. 539M38668

Beautifully presented throughout

One of only 458 Fiestas produced for 1953

The rarest of GM's 1953 dream cars

One defining event of 1950s American car culture was General Motors' traveling Motorama. It was a truly extraordinary, no-expense-spared display of dazzling technology, stunning styling, and modern American ingenuity. The series of dramatic styling exercises by the legendary Harley Earl captivated the public, but most of the designs were never made for sale. For 1953, though, GM made an exception. The company offered three of the previous year's "dream cars" in limited production numbers to the lucky few who could afford

the staggering price tags and had the personal influence required to secure one from "the General." The three models available were the Cadillac Series 62 Eldorado, the Buick Roadmaster Skylark, and the car offered here, the Oldsmobile Ninety-Eight Fiesta.

Though all three were produced in very limited numbers, the scarcest of all was the Oldsmobile "98" Fiesta, which cost an astonishing \$5,715. It was, and remains to this day, a stunning design that pioneered several features at Oldsmobile, including the cut-down,



wraparound windshield, “spinner” wheel covers soon to be popular in the Kustoms crowd, and attractive two-tone paint schemes in exclusive colors. Each Fiesta came well equipped with leather upholstery, power steering, power brakes, power windows, and a power seat. It was the rarest of the 1953 GM Trifecta of dream cars, with a total production run of just 458 examples. Today, surviving examples rarely become available for sale.

The 1953 Oldsmobile Ninety-Eight Fiesta offered here is finished in Alpine White over Turquoise two-tone with a white convertible top. The car rides on wide whitewall tires mounted on steel wheels featuring factory wheel covers. The exterior is accented by a two-tone turquoise-and-white interior featuring a clock and a Super De Luxe radio. Furthermore, the car is equipped with power antenna, seat, windows, and steering. This Fiesta was a participant in the Glenmoor Gathering on two occasions, cementing its status as one of the finer examples of this incredibly rare luxury convertible.

Presented in particularly beautiful colors, this Fiesta is a wonderful example of the car that, in their 1953 advertising, AC Spark Plug referred to as a “sportster,” establishing it as the most stylish car produced in Lansing during the Rocket Age.



1960 Cadillac Eldorado Biarritz Convertible



2141

\$90,000 - \$120,000

390 cu. in. V-8 engine; automatic transmission

Stunning body-off restored example

Equipped with air-conditioning and Autronic Eye

One of only 1,285 produced in 1960

By the late fifties, Cadillac would reign supreme over the full-sized luxury car market in North America. Although the extravagant 1959 model caused a sensation when introduced, it later came to be viewed as the pinnacle of automotive styling excess.

For its 1960 models, Cadillac significantly refined their approach, shrinking the exaggerated fins from the previous year, reducing the egregious use of chrome trim, and in many other ways creating an infinitely more elegant statement. The full complement of power accessories was retained; however, so many aficionados today consider the 1960 Cadillac as the ultimate iteration. GM's executive director of styling from that period, Dave Hollis, once remarked, "I finally got it right with the 1960 Cadillac...The '60 Cadillac is pure Grace Kelly."

With a total of 13 Cadillac models issued in three series (plus one limited-production custom chassis), the Eldorado Biarritz convertible was the most elegant and desirable of all. Only 1,285 units were produced, costing over \$7,000 new, ensuring exclusivity then and now.

This 1960 Cadillac Eldorado Biarritz Convertible offered from the Meurer Collection is a truly wonderful example. Mr. Meurer purchased the car from a Minnesota Cadillac collector in 1990, driving it home over 700 trouble-free miles. Several years later a full body-off





restoration was commissioned. This was highlighted by new paint in the correct Carrara Green, refinished chrome and stainless trim, a new top, and a fully rebuilt drivetrain. Since its completion the car has been enjoyed and shown at concours events, including St. John's. This example is equipped with air-conditioning in addition to a power convertible top, windows, steering, and brakes. The interior is completed in green leather and features an Autronic Eye, AM-FM radio, and a clock. It rides on wide whitewall tires mounted on steel wheels featuring factory wheel covers.

This beautifully restored Eldorado Biarritz Convertible is a wonderful example of the model and one that is sure to turn heads today, as it did many years ago when new. The 1960 Cadillac Eldorado Biarritz Convertible remains one of the more iconic cars from the fin era and one that should be a part of any discerning collection.



1935 Packard Twelve Convertible Sedan BY ROLLSTON

\$175,000 - \$225,000

VEHICLE NO. 1208-213



2142

Stunning one-off coachwork by Rollston
 Purchased new by Augustus Schell Hutchins
 Single-family ownership from 1935 to 1959
 Recently repainted and beautifully presented
 CCCA Full Classic

Over thirty-five thousand Packard Twelves were produced from 1933 to 1939; it is considered by many to be one of the finest automobiles produced by Packard and one of the most significant creations of the classic car era. The long and flowing front hood hid a 473-cubic-inch side-valve twelve-cylinder engine that was refined, powerful, smooth, and quiet.

The engine was originally destined for a front-wheel-drive project which eventually proved to have weaknesses. That and the anticipated development cost were too much to be practical, so Packard decided to scrap the idea. Cadillac had introduced their 16-cylinder engine, and other marques such as Pierce-Arrow were improving the performance of their offerings. Packard was feeling the pressure and decided to place the engine into the Deluxe Eight chassis and dubbed it the Twin Six. The name was in honor of Packard's achievement fifteen years earlier when they introduced their first 12-cylinder engine. By 1933 the name was changed to Twelve to be consistent with the nomenclature used on other Packard models.

The convertible sedan offered here is a superb example of the breed, built on the 144-inch wheelbase 1208-series twelve-cylinder chassis. The 473-cubic-inch twelve-cylinder featured Stromberg carburetors and produced 175 horsepower, a huge number for the day. This car is believed to be a one-off body built by Rollston at a price tag of roughly \$7,500. It is no wonder that only the wealthiest and most influential families could afford such a machine. It is said that this example was built for Augustus Schell Hutchins, a lawyer and the son of Waldo Hutchins, a long-serving member on New York City's Central Park Board of Commissioners. It's believed to have remained in the family until 1959 and was later purchased by one of the early presidents of the CCCA. Fully restored in 1967, the



car earned its CCCA Senior badge in 1968 and still wears that badge to this day. Purchased by Ed Meurer in 1972, the car has recently been fully repainted and was displayed at the 2018 Concours d'Elegance of America at St. John's.

An inimitable automobile, with rarity, exclusivity, and superb performance, it is ideal for showing or touring and is a CCCA Full Classic. It is worthy of inclusion in any of the world's finest Packard, Full Classic, or pre-war automobile collections.



1957 Chevrolet Bel Air Convertible

\$80,000 - \$100,000
OFFERED WITHOUT RESERVE



2143

220 hp, 283 cu. in. V-8 with Power Pack option

Powerglide automatic transmission

Fitted with power steering and brakes

Features desirable continental kit

Highly optioned with, dual spot lights, front and rear bumper guard options, dual antennas, trunk edge moulding, door handle guards, and dual rear view mirrors





2144

1990 Ford Bronco II XLT

\$10,000 - \$15,000

- 2.9-liter V-6 engine
- Manual transmission
- Four-wheel-drive transfer case
- Aftermarket wheels
- Trailer hitch



2145

1957 Ford Thunderbird Replica

\$20,000 - \$25,000 OFFERED WITHOUT RESERVE

- Replica Thunderbird with fiberglass body
- 351 cu. in. V-8; automatic transmission
- Fitted with power steering and brakes
- Equipped with 'porthole' hardtop
- Two-tone interior features AM/FM radio and heater



2146

1971 Pontiac Trans Am 455 H.O.

\$50,000 - \$60,000

- 455 cu. in. High Output V-8 engine; automatic transmission
- Fitted with aftermarket MSD ignition
- Wonderful color combination
- Equipped with air conditioning; power steering and brakes
- Rides on Goodyear Polyglas GT tires; 'Snowflake' wheels



2149

1930 Lincoln Model L-179 Coupe

\$25,000 - \$35,000 OFFERED WITHOUT RESERVE

- 90 bhp, 384.8 cu. in. V-8 engine; three-speed manual transmission
- Highly original example throughout; running driving vehicle
- Ideal for preservation class or as a candidate for restoration
- Retains original matching number engine
- One of 275 Model L-179s produced in 1930
- Classic Car Club of America (CCCA) Full Classic
- Final year of Lincoln's L-Series



2150

1941 Plymouth Super Deluxe Convertible
\$25,000 - \$30,000



2152

1992 Lincoln Town Car
\$12,000 - \$16,000



2153

1978 Cadillac Eldorado Biarritz Coupe
\$16,000 - \$18,000 OFFERED WITHOUT RESERVE



2154

1964 Porsche 356 SC 'Outlaw'
\$50,000 - \$60,000



2155

1976 Mercedes-Benz 450 SL
\$12,000 - \$16,000 OFFERED WITHOUT RESERVE



2156

1982 Chevrolet Corvette 'Collectors Edition'
\$20,000 - \$25,000



2160

1993 Lincoln Town Car

\$12,000 - \$16,000



2162

1955 Chevrolet 210 Bel Air Custom

\$35,000 - \$45,000



2163

1974 Lincoln Continental Mark IV

\$14,000 - \$16,000 OFFERED WITHOUT RESERVE



2164

1995 Jaguar XJS Convertible 'Celebration Edition'

\$12,000 - \$15,000



2165

1937 Packard One Twenty Touring Sedan

\$20,000 - \$30,000



2166

1965 Ford F-100 Pickup

\$28,000 - \$32,000



2167

1947 Studebaker M-5 Pickup
\$28,000 - \$32,000

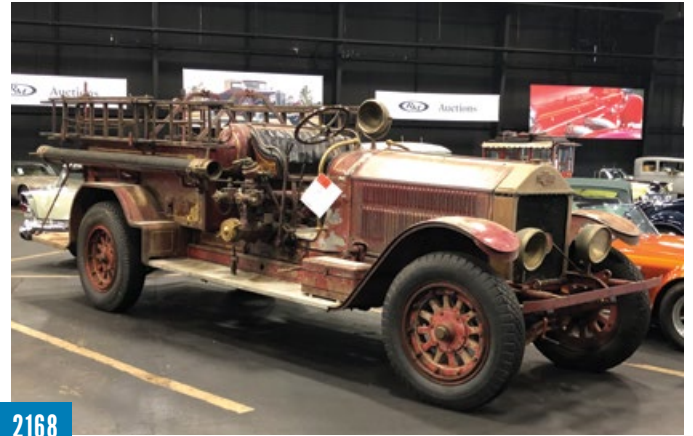

2168

1929 American LaFrance Fire Truck
\$20,000 - \$30,000



2170

1956 Cadillac Series 62 Sedan
\$25,000 - \$35,000



2171

1929 Lincoln Model L-179 Coupe
\$20,000 - \$25,000 OFFERED WITHOUT RESERVE



2172

1973 Cadillac Eldorado Convertible
Indy 500 Pace Car Replica
\$30,000 - \$35,000

DELIVERED NEW AS A SR-X20
INDY 500 PACE CAR REPLIC. THIS
EXAMPLE HAS BEEN REPAINTED.



2173

1965 Cadillac Calais Hardtop Sedan
\$20,000 - \$30,000 OFFERED WITHOUT RESERVE



2174

1934 DeSoto Airflow Sedan

\$30,000 - \$40,000

299 cu. in. inline six-cylinder engine

Three-speed manual transmission

Frame-off restored; accompanied by photographs

Ground breaking aero design with early unibody construction



2175

1985 Cadillac Eldorado Coupe

\$10,000 - \$12,000 OFFERED WITHOUT RESERVE

Offered from the Gene and Shirley Barnhart Collection

135 hp, 4.1-liter V-8; automatic transmission

Equipped with AM/FM radio

Featured with optional touring suspension

Power windows, steering, and brakes

Rides on thin whitewall tires



2177

2001 Porsche 911 Turbo Coupe

\$30,000 - \$38,000

415 hp, 3.6 liter twin-turbocharged flat six-cylinder engine

Six-speed manual transmission

Finished in Arctic Silver Metallic with Black leather interior

Exterior features Carbon Fibre wrapped hood; wrapped wing

RUF steering wheel and aftermarket Kenwood unit with navigation

Accompanied by owner's manual with pouch



2178

1962 Cadillac Series 62 Coupe DeVille

\$30,000 - \$40,000 OFFERED WITHOUT RESERVE

Less than 5,000 original miles; single-family ownership for roughly 40 years

Consignor's father purchased from original owner in late 1970s with less than 2,000 miles

Finished in original Sandalwood over original green cloth and leather interior

Presented with owner's manual and dealer brochure

Equipped with power windows, steering, and brakes

Interior features clock and radio

Stunning time capsule ready to be enjoyed



2179

1969 Chevrolet Malibu Chevelle Sport Coupe

\$66,000 - \$70,000



2180

1971 Ford Mustang Mach 1

\$62,000 - \$67,000



2181

1930 Ford Model A Deluxe Roadster

\$20,000 - \$25,000 OFFERED WITHOUT RESERVE



2182

1979 Pontiac Firebird Trans Am

\$36,000 - \$40,000



2184

2008 Chevrolet Corvette Indy 500 Pace Car Replica

\$36,000 - \$40,000



2185

1955 MG TF 1500

\$20,000 - \$30,000 OFFERED WITHOUT RESERVE



2187

1964 Datsun Fairlady

\$15,000 - \$20,000



2188

1954 Chevrolet Bel Air Two-Door Sedan

\$15,000 - \$20,000



2189

2002 Ford Thunderbird

\$15,000 - \$20,000



2190

1946 Chevrolet Pickup

\$20,000 - \$25,000



2192

1978 Lincoln Continental Mark V

\$12,000 - \$14,000 OFFERED WITHOUT RESERVE



2194

1940 Buick Special Four-Door Sedan

\$15,000 - \$20,000 OFFERED WITHOUT RESERVE



Lot 3125: 1971 Ferrari 365 GTB/4 Daytona Berlinetta

29 AUGUST-1 SEPTEMBER 2019
AUBURN AUCTION PARK

FALL

AUBURN

AUCTION • CAR CORRAL • SWAP MEET

Saturday

| 31 August 2019

| Cars 11:00 a.m.





3006

1955 MG TF

\$20,000 - \$30,000 OFFERED WITHOUT RESERVE



3007

1968 Rolls-Royce Silver Shadow

\$15,000 - \$20,000 OFFERED WITHOUT RESERVE



3008

1930 Ford Model A Roadster

\$25,000 - \$30,000 OFFERED WITHOUT RESERVE



3009

1985 Volkswagen Westfalia Camper

\$25,000 - \$30,000 OFFERED WITHOUT RESERVE



3010

1950 Hall Craft

\$30,000 - \$40,000 OFFERED WITHOUT RESERVE



3011

2000 Prevost Marathon Coach

\$80,000 - \$120,000



3013

1959 Austin-Healey Sprite

\$10,000 - \$15,000 OFFERED WITHOUT RESERVE



3016

1979 Mercedes-Benz 450 SL

\$6,000 - \$10,000 OFFERED WITHOUT RESERVE



3017

1927 Lincoln Model L Coupe

\$25,000 - \$35,000 OFFERED WITHOUT RESERVE



3018

1965 Chevrolet Suburban Custom

\$35,000 - \$40,000



3019

1979 Pontiac Firebird Trans Am

\$36,000 - \$40,000



3020

1964 Austin-Healey 3000 Mk III B18

\$70,000 - \$90,000



3021

1979 Pontiac Firebird Trans Am

\$18,000 - \$22,000 OFFERED WITHOUT RESERVE

V-8 engine; automatic transmission

Power windows, steering, and brakes

Sold new through Somerset Pontiac-GMC of Troy, MI

Rides on Goodyear Eagle GTII tires

Copy of window sticker included



3022

2007 Noble M400

\$70,000 - \$80,000

Powered by a Ford Duratec 3.0-liter twin-turbocharged V-6 engine

Six-speed manual transmission

One-owner from new and meticulously cared for

Less than 3,400 actual miles

Factory installed air conditioning and optional upgraded wheels

Recent service including new tires last year

0-60-mph in 3.2-seconds; top speed of 187-mph



3024

1963 Amphicar 770

\$35,000 - \$45,000

Inline four-cylinder engine

Four-speed manual transmission

Two-tone interior, believed to be original

Equipped with dual sideview mirrors

Rides on thin whitewall tires; factory hub caps

Accompanied by parts



3025

1950 Ford F-1 Pickup

\$30,000 - \$35,000 OFFERED WITHOUT RESERVE

Powered by a flathead V-8 engine

Three-speed manual transmission

Interior is equipped with a radio and heater

Features a wood bed with chrome slats

Rides on whitewall tires; factory hub caps



3026

1980 Mercedes-Benz 450 SLC

\$20,000 - \$30,000 OFFERED WITHOUT RESERVE

4.5-liter V-8 engine; automatic transmission
 Finished in Silver Blue Metallic with Blue leather interior
 Very nice example; odometer displays less than 52,900 miles
 Power windows, sunroof, antenna, steering and brakes
 Interior features a Becker Mexico radio with cassette
 Rides on Michelin MXV tires; factory wheels
 Accompanied by manuals and tool roll



3027

2015 Can-Am Maverick Turbo XDS

\$4,000 - \$6,000 OFFERED WITHOUT RESERVE

121 hp, 976-cc turbocharged two-cylinder; continuously variable transmission
 Engine features forged pistons and high capacity injectors
 Equipped with Fox Racing Shocks and race-inspired bucket seats
 Fitted with TTA rear suspension with 16-inches of travel
 Original MSRP of \$22,099



3028

1971 Jaguar E-Type Series 3 V12 2+2

\$35,000 - \$40,000

Powered by a fuel-injected V-12 engine
 Converted to five-speed manual transmission
 Finished in British Racing Green with a black interior
 Southern car fitted with factory air conditioning
 Michelin tires mounted on chrome wire wheels



3030

1918 Harroun Model A-1 Touring

\$15,000 - \$20,000 OFFERED WITHOUT RESERVE

Designed by Ray Harroun, the winner of the first Indianapolis 500
 Overhead valve four cylinder engine with three speed manual transmission
 One of 326 Harrouns built for 1918
 Believed to be one of two extant examples
 Wholly original, unrestored, and believed to be complete

**3031****1995 Hummer H1 SUT****\$45,000 - \$50,000**

6.5-liter V-8 diesel engine; four-wheel-drive

Equipped with roof rack, front bumper guard, and winch

Driven 250-miles to auction; consignor sates drives nice at 70 mph

Extra set of wheels and tires

Original roof rack and front bumper guard

All new LED lights, signals, stereo, seat belts, window operators and switches

**3032****1967 Chevrolet Corvette Sting Ray 427 Coupe****\$100,000 - \$140,000**

Powered by a 427 cu. in. V-8 engine

Four-speed manual transmission

Restored to a high standard

Equipped with power brakes

Interior features clock and AM/FM radio

Redline tires mounted on aluminum bolt-on wheels

**3033****1966 Amphicar 770****\$50,000 - \$60,000**

Model 770 denotes 7 mph in water and 70 mph on land

European delivery example with 7,600 km (4,750 miles) from new

Previous owner had for 48 years; found in Holland in 1970 with only 250 km

White with original red interior and new top

Original Michelin tires, original spare, jack and tool kit

All mechanical equipment in good working order

Rust-free car example; new paint about 10-years ago

Equipped with twin bilge pumps; last in water September 2018

**3034****1957 Chevrolet Bel Air Convertible****\$85,000 - \$100,000**

220 hp, 283 cu. in. V-8 with Power Pack option

Powerglide automatic transmission

Finished in Tropical Turquoise and white over matching interior

Fitted with power top, steering, and brakes; front brakes upgraded to discs

Optioned with radio dual antennas, clock, and door handle guards

Rides on whitewall tires mounted on color matched steel wheels featuring "spinner" wheel covers



3036

1957 Dodge Royal Lancer Super D-500 Coupe

\$50,000 - \$60,000

- 310 hp, 325 cu. in. Hemi V-8 with dual-quad carburation
- Powerflite push-button automatic transmission
- Power windows, steering, and brakes
- Attractive two-tone black and gold paint scheme



3037

1965 Pontiac Tempest LeMans GTO Hardtop

\$60,000 - \$75,000

- 389 cu. in. V-8 featuring Tri-Power carburetion
- Four-speed manual transmission with Hurst shifter
- Meticulously cared-for example coming out of long-term ownership
- Originally sold through Doug Willey Pontiac Inc. of Birmingham, AL
- Offered with original window sticker and Pontiac Historical Services documentation, and restoration photographs
- Includes two sets of spare wheels; Hurst five-spokes with redline tires and painted steel wheels with redline tires



3038

1967 Porsche 912 'Soft-Window' Targa

\$35,000 - \$50,000 OFFERED WITHOUT RESERVE

- Car has been repainted; presents beautifully
- Interior is finished in black vinyl featuring an AM/FM radio
- Service records dating back to 1982
- Retains original books and manuals
- Rides on Pirelli radial tires
- Rare 'Soft-Window' Targa



3039

1977 Cadillac Eldorado

\$18,000 - \$24,000

- 425 cu. in. V-8 engine
- Turbo Hydra-Matic automatic transmission
- Equipped with air conditioning
- Power door locks, windows, steering, brakes
- Rides on thin whitewall tires



3040

1937 Packard Town Car by Rollston

\$45,000 - \$60,000

Straight eight-cylinder engine; three-speed manual transmission

Offered from long-term ownership

Equipped with divider window and intercom system

Features dash clock and rear jump seats

Fitted with aftermarket turn signal switch

Rides on wide whitewall tires



3042

1971 Chevrolet Corvette Convertible

\$30,000 - \$35,000 OFFERED WITHOUT RESERVE

350 cu. in. V-8; four-speed manual transmission

Beautifully restored example

Finished in Ontario Orange over Black leather

Equipped with AM/FM radio and power brakes

Accompanied by owner's manual

Rides on Firestone Wide Oval tires mounted on Rally wheels



3043

1977 Cadillac Coupe Deville

\$18,000 - \$24,000

V-8 engine; automatic transmission

Power door locks, windows, steering, and brakes

Equipped with air conditioning

Rides on thin white wall tires



3044

1929 Packard Custom Eight Dual-Cowl Phaeton

\$85,000 - \$95,000

Sold new to a Mr. Fairchild of Pennsylvania, under his ownership until 1964

In 1964 the car was restored by his son and driven on the Glidden Tour

Sold to well-known collector in Indiana in 1994; consignor purchased in 2014

Since 2014 maintained by restorer Bob McKeown in Ohio

Features a new wiring harness, heavy-duty battery cables, radiator, rebuilt water pump, and the addition of turn signals into the running lights

Wonderful older restoration, the consignor states it's tour ready



3045

1954 Chevrolet Corvette

\$55,000 - \$65,000

235 cu. in. 'Blue Flame Six' engine featuring three Carter carburetors
 Finished in Polo White over red; less than 17,000 original miles
 Long term single-family ownership from 1978-2018
 Sold as a barn find example in 2018
 Since been cleaned and mechanically sorted; ready to be enjoyed
 One of only 3,640 Corvettes produced for 1954



3046

1966 Alfa Romeo Giulietta Spider by Pininfarina

\$35,000 - \$50,000 OFFERED WITHOUT RESERVE

Inline four-cylinder engine
 Five-speed manual transmission
 Equipped with Talbot driver mirror
 Black leather interior features Nardi wood steering wheel and AM/FM radio
 Lovely example in desirable color combination



3047

1967 Chevrolet Corvette Sting Ray 427 Convertible

\$125,000 - \$135,000

Retains original L71 435 hp, 427 cu. in. V-8 engine
 Four-speed, close ratio manual transmission
 Frame-off restoration; covered less than 600 miles since completion
 Finished in Rally Red with black stinger and white convertible top
 Features side exhaust, aluminum wheels, and factory hardtop
 Interior is equipped with radio, dash clock, and headrests
 One of 3,754 built with L71 engine for 1967



3048

1991 BMW M5

\$25,000 - \$30,000

3.6-liter inline six-cylinder engine
 Five-speed manual transmission
 Extremely well preserved example
 Accompanied by tool kit and owner's manuals
 Features trunk-mounted CD changer

**3049****1968 Chevrolet Camaro RS Coupe**

\$30,000 - \$35,000

Original low mileage California rust-free car stripped to bare metal with one repaint

Equipped with the RS/SS package

Interior features bucket seats, console; factory air conditioning

Recently serviced – new fuel pump and carburetor

Rides on Rally wheels

Power steering

**3050****1987 BMW Alpina B7 Turbo Coupé/3**

\$140,000 - \$160,000

3.4-liter turbocharged inline-six

Six-speed manual transmission

One of only 17 highly desirable catalyst-equipped B7 Turbo Coupés

Gorgeous black over red leather color scheme

**3051****1985 Renault 5 Turbo 2**

\$80,000 - \$90,000

1.4-liter turbocharged four-cylinder engine

Five-speed manual transmission

A brilliant example of one of the most desirable rally cars of the 1980s

**3052****1989 Ferrari 412**

\$80,000 - \$100,000

335 hp 4.9-liter V-12 engine

Highly desirable five-speed manual transmission

Lovely color combination

Believed to be one of 576 produced



3053

1988 Mercedes-Benz 560 SL

\$50,000 - \$60,000

5.6-liter V-8 engine; automatic transmission

Finished in the desirable shade of Signal Red

Less than 21,900 miles from new

Original United States delivery; retains U.S.-spec rubber bumpers



3054

1988 BMW 635 CSi

\$40,000 - \$50,000

208 bhp, 3.5-liter M30B5 inline six-cylinder engine

Four-speed automatic transmission

Delivered new to Japan

Finished in black over black



3055

1982 BMW Alpina B7 Turbo Coupé

\$90,000 - \$100,000

300 bhp turbocharged variant of BMW's six-cylinder engine

Equipped with a manual transmission

Sunning color combination with Alpina graphics

One of only 183 B7 Turbo Coupés

A gentleman's supercar



3056

◇ **1996 Ferrari F355 Spider**

\$70,000 - \$85,000 OFFERED WITHOUT RESERVE

Less than 18,000 actual miles

Desirable six-speed manual gearbox example

Finished in stunning Giallo Modena over Nero leather

"Sticky buttons" have been replaced and refinished by Sticky RX

Includes books, tools, and service records

One of approximately 2,690 Ferrari 355 Spiders fitted with a manual transmission

2003 BMW M3

**3057****\$35,000 - \$45,000**

3.2-liter inline six-cylinder engine;
six-speed manual transmission

Finished in attractive Imola
Red over black interior

Aftermarket equipment includes
H&R lowering springs

Originally purchased through
Riverside BMW in California

Options include power adjustable
sports sets, Harman Kardon
stereo system, auto-dimming
mirror, and Titan shadow trim

Includes owner's manuals and car cover

1968 BMW 2002

**3058****\$18,000 - \$22,000**

2.0-liter inline four-cylinder engine

Four-speed manual transmission

Owner states it's a mostly
original example

Fitted with Tii exhaust
(new from manifold back in 2017)

Features air conditioning and
Blaupunkt AM/FM radio

Desirable example from the first
year of 2002 production

1966 Duesenberg Model D Concept

\$300,000 - \$350,000



3059

Just 800 miles from new
 Uprated 425 hp 440-cubic-inch V-8 engine
 Amazing original paint
 Original cashmere-and-leather interior



In 1966, some 30 years after the original Duesenberg had gone out of business, the ultra-luxury marque was set to unveil an all-new vehicle. The rebirth had begun in 1964, when Fred A. "Fritz" Duesenberg, son of the legendary Augie Duesenberg, partnered with Texas real estate baron Fred J. McManis Jr. Some \$5 million in startup capital was promised, and the company began work on the new car.

Based on the 1966 Imperial, the car had a 440-cubic-inch V-8 with a 137.5-inch wheelbase chassis. An automatic transmission and four-wheel disc brakes were also standard. It was then fitted with sumptuous coachwork penned by Virgil Exner and handcrafted by Carrozzeria Ghia. As is to be expected from a Duesenberg, the car was lavishly appointed. Standard equipment included climate-control A/C, autopilot, and AM/FM radio, rear instrumentation similar to some Model J Duesenbergs, an altimeter, and dual fuel tanks. A built-in television, a bar, rear seat instrumentation, Motorola stereo tap, and magnesium wheels were all optional.

It is believed that around 50 orders were received for the new car, including from such stars as Elvis Presley and comedian Jerry Lewis. The company's initial plans had been to build around 1,000 units, but when corporate financing fell through, the effort folded and no production examples were ever completed. The only remaining glimpse of the latter-day Duesenberg is the prototype Model D offered here.

The car offered here was displayed in the Auburn Cord Duesenberg museum over 30 years before joining the

Bortz Auto Collection of concept cars. It remains overwhelmingly original and has traveled less than 800 miles from new. The car wears its original maroon paint with the exception of a repaint of the passenger front fender. It also retains its original cashmere-and-leather interior.

Featured in numerous magazines and publications, such as *Car & Driver* and *Popular Mechanics*, this historic and important automobile is the last true Duesenberg built and the only post-war example with direct family claim to the original ACD company. This one-of-one automobile demands serious attention and deserves inclusion in any of the finest collections in the world.



1958 Chevrolet Impala Convertible

**3060****\$75,000 - \$85,000**

348 cu. in. Tri-Power V-8
Automatic transmission
Finished in attractive color combination
Power convertible top, seat, steering, and brakes
Equipped with dual spotlight sideview mirrors, dual antennas, and fender skirts
Interior features clock and radio
Rides on wide whitewall tires

1968 Chevrolet Camaro RS Z28 Coupe

**3061****\$55,000 - \$60,000**

Retains its original, numbers matching 302 cu. in. V-8 engine
M21 close ratio four-speed manual transmission
12-bolt Posi-Traction rear axle with 3.73:1 gearing
Finished in Corvette Bronze with black interior
15-inch Rally wheels with power front disc brakes
Stunning example of one of the more desirable muscle cars

1932 Auburn 8-100 Boattail Speedster BY GLENN PRAY

\$100,000 - \$120,000

Powered by Inline eight-cylinder engine; manual transmission

Constructed on original Auburn chassis with Glenn Pray fiberglass body

This example was once Glenn Pray's personal car

Tastefully appointed with Woodlite headlights

Equipped with a dual ratio rear end

Rides on whitewall tires mounted on knock-off wire wheels

Beautiful Classic Era styling

3062



1969 Chevrolet Camaro Indy 500 Pace Car Replica

\$65,000 - \$75,000

300 hp, 350 cu. in. 'Turbo Fire' V-8

Console-shift automatic transmission

Wonderful newer restoration

Finished in 1969 Pace Car livery with correct hounds-tooth seats

Power top, steering, and brakes

Fitted with air conditioning

3063





1970 Ford Mustang Boss 429

3064

\$210,000 - \$220,000

CHASSIS NO. 0F02Z131454

One of just 500 Boss 429s built for 1970

Four documented owners from new

Correct Grabber Blue paint with original white interior

Racing homologation models are often the fastest, most pure, and most desirable cars on the collector market. The car offered here, the legendary 1970 Ford Mustang Boss 429, is certainly no exception. In the late 1960s, Chrysler ruled NASCAR with its legendary 426 Hemi engine but Ford decided to go all out to catch up. They developed a 429-cu. in. version of the Ford 385 V-8 with specially modified oil and water passages, four bolt main bearings, and all forged steel internal components. Ford gave the new engine an insurance-friendly rating of 375 hp, though the actual output in

stock form is said to be well over 500 hp.

To meet NASCAR's engine homologation rules, Ford chose to place the new 429 into the Mustang, thereby creating the highly desirable Boss 429 Mustang variant. Originally offered for the 1969 model year, the Boss 429 continued for 1970 and was offered in five factory colors, including eye-catching Grabber Blue, the original color of the car offered here. With just 500 examples completed, the 1970 Boss 429 was and is one of the most desirable factory Fords ever built and is in fact rarer than the 1969 model which saw 839 examples produced.



The car offered here is an overwhelmingly original example of this limited-production muscle car. The car has never been fully restored and has seen just a single repaint in its correct shade of Grabber Blue. It still wears the factory-original code TW White vinyl interior. It has had just four owners since new, including nearly 30 years in proper heated storage in the hands of its third owner. Removed from this long-term storage approximately three years ago, the fourth owner has had some \$10,000 in recent work completed, including the fitting of a period-correct carburetor and reproduction export brace. The owner reports that the car runs and drives as expected and is fully ready to be enjoyed.

Included in the sale is an extensive file of historic documentation, including copies of the Ford Motor Company dealer contracts, along with the original sales invoice. Also included is a copy of the Marti Report that fully documents the car's build history as well as invoices for the engine work. In short, with its incredible originality and documented history, this may be an unrepeatable opportunity to own one of the most desirable examples of one of the toughest Mustangs of the period.



**3065****1933 LaSalle Convertible Coupe**

\$125,000 - \$150,000

Flathead V-8; floor-shift three-speed manual transmission

Presented with wonderful newer restoration

Recently upholstered with new top by RM Auto Restoration

Features dual covered side-mounted spares

Utilizes rear-mounted luggage rack

Rides on Firestone whitewall tires mounted on wire wheels with factory hub caps

**3066****1989 Porsche 911 Turbo Coupe**

\$150,000 - \$175,000

Well optioned per COA; less than 39,000 original miles

Incredibly original example, retaining its original paint and interior

Desirable last year of production for the 930 Turbo and the only year for the G50 transmission

Rare color combination with painted to match wheels

Well documented service history; clean CARFAX

Complete with original books, tools, jack, and spare

**3067****1969 Dodge Charger 500 SE**

\$75,000 - \$95,000

Offered from The RPM Collection

440 cu. in. 'Magnum' V-8; automatic transmission

Presented with wonderful newer restoration

Equipped with air conditioning and power brakes

Interior features bucket seats, console, Rallye dash, and AM radio

Adorned by '500' rear decal stripe

Believed to be one of two finished in this color

Rides on Magnum wheels with redline tires

**3068****1963 Studebaker Avanti R3**

\$100,000 - \$125,000

R3 304.5 cu. in. supercharged V-8

Automatic transmission; power steering and brakes

Believed to be the second to last Studebaker Avanti produced

Documented ownership

Rides on Michelin Pilot tires mounted on Halibrand wheels

Believed to be one of only nine R3 Avantis produced

1969 Dodge Dart GTS 440 Coupe

\$80,000 - \$110,000

3069

Offered from The RPM Collection

M-code 440 cu. in. 375 hp V-8

Utilizes console-shifted Torqueflite automatic transmission

Preserved example, never fully restored

Power steering and brakes

Accompanied with copy of broadcast sheet



1971 Plymouth 'Cuda Coupe

\$80,000 - \$95,000

3070

Offered from The RPM Collection

340 cu. in. V-8; automatic transmission

Finished in the High Impact shade of Curious Yellow with black vinyl top

Equipped with power brakes and air conditioning

Reportedly one of the early production cars used for auto shows to display the new 1971 design

Purchased early in the car's life by a woman in Ohio, she owned the car until 2005

Purchased in 2005 by owner in Illinois and had the car completely restored back to factory colors



1971 Plymouth 'Cuda Convertible

3072
\$150,000 - \$200,000

 CHASSIS NO. **BS27H1B438390**

Offered from The RPM Collection

Reportedly the last 'Cuda convertible built

Snow White over orange vinyl

340 cu. in. V-8; TorqueFlight automatic transmission

Well-optioned example

With its 1970 redesign, the Plymouth Barracuda came into its own as a coupe or convertible that married performance and styling like never before. The dramatic sloped roofline carried into the new year, but the E-Body Barracuda no longer had anything other than space in a showroom in common with the workaday Valiant.

It was a move that allowed the car to flourish as a performance model, especially when ordered as a 'Cuda, a carryover name from a trim package offered at the end of the last design's run. This go-around, the 'Cuda's engine

bay could swallow ever larger V-8s paired with manual and automatic transmissions. Minor updates for 1971 brought a new grille design with four headlights and distinctive undersea-inspired "gills" on the fenders. If any 'Cuda is a perfect example of the breed, it's the '71.

This '71 'Cuda convertible comes from the second year of production, but only by a hair, as it rolled off the Hamtramck, Michigan, assembly line just before the changeover to the 1972 model year. This example is reportedly the last E-Body convertible built and is said to have been assembled on 22 June 1971.



Plymouth ensured that the 'Cuda convertible would go out in style. The factory-correct Snow White paint, black graphics, and black vinyl power-operated top deliver exactly the contrast Plymouth had in mind with the unusual orange vinyl-upholstered interior. The factory buckets are separated by a black center console with wood trim, providing a sporty look appropriate for a car equipped with the four-barrel, 275-horsepower, 340 cubic-inch V-8. A three-speed TorqueFlight automatic ensures smooth power delivery to the rear wheels, should the owner want to exercise the period-style Goodyear Polyglas rubber. Careful attention has been paid to underhood detailing down to the Mopar-sourced battery.

Other factory equipment retained on this well-optioned example include an AM/FM radio, remote exterior mirrors, and the eye-catching dual-intake sport hood equipped with pins. An attractive luggage rack has been added to the rear deck.



2005 Ford GT

\$300,000 - \$350,000

CHASSIS NO. 1FAFP90S75Y400471



3073

Two-option example; McIntosh radio and forged BBS wheels

One of only 26 finished in Quick Silver with side stripes for 2005

Displays 313 miles at time of cataloguing

Rare hood-stripe delete



Built in celebration of the 100th anniversary of Ford Motor Company, Ford promoted the GT upon its introduction as “The Pace Car for an Entire Company,” and it soon lived up to its name. An homage to the iconic GT40 that led Ford to a four-year winning streak at the 24 Hours of Le Mans from 1966–1969, the new GT’s silhouette was instantly recognizable to motorsport fans worldwide as an icon of American performance. More to the point, the new GT was destined to be a world beater and take on the best of the best from around the globe, including Ferrari.

Continuing the tradition of the legendary GT40, it was only appropriate the new GT be powered by a supercharged 5.4-liter V-8 engine. The 32-valve cylinder heads from the Mustang SVT Cobra R were modified with a thicker wall casting in the exhaust port, and a new camshaft provided increased lift and duration. Atop the V-8 sits a Lysholm twin-screw supercharger forcing a maximum 11.7 psi of boost into the engine. As stated from the factory, the engine produces 550 hp and 500 foot-pounds of torque. Four-piston aluminum Brembo brake calipers with cross-drilled and ventilated rotors on all four wheels made sure to bring the vehicle to an abrupt stop from any speed. Most impressively, a top speed of 205 mph and a 0–60 time of 3.3 seconds place the GT in closer competition

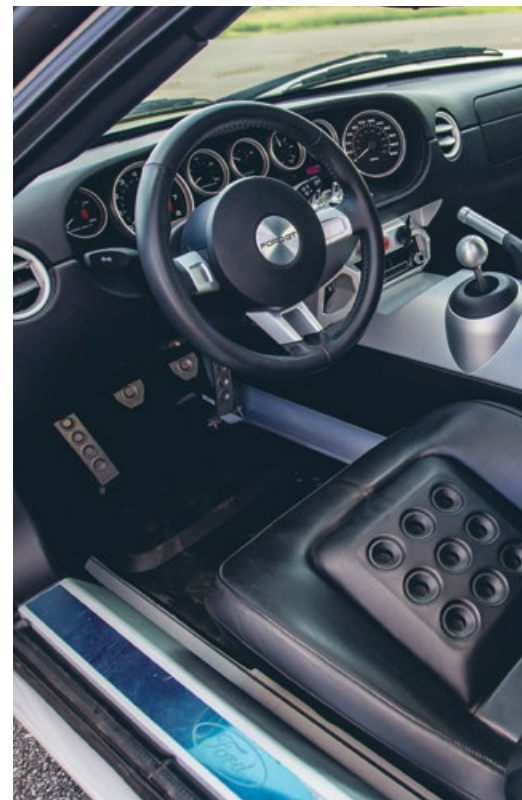

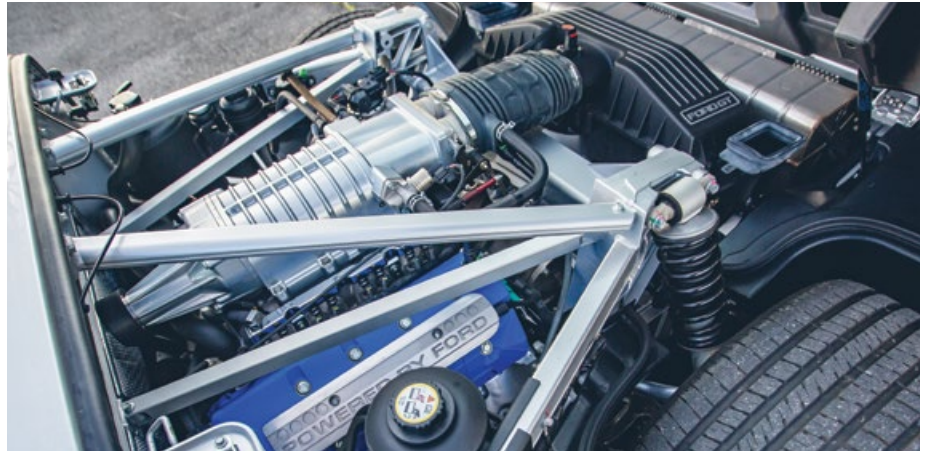

to the Porsche Carrera GT and Mercedes-McLaren SLR, rather than the benchmarked Ferrari 360.

An understated, over-the-top stripe-delete example, it's one of only 26 produced for 2005 in Quick Silver with side stripes only. The car is in near-factory condition and presents exceptionally well throughout, the odometer displaying only 313 miles at time of cataloguing. Built at Ford's Wixom plant, the GT was shipped via rail to the West Coast, where it was delivered to Kearny Mesa Ford of San Diego, California. A two-option example, the car features the upgraded McIntosh radio and lightweight forged BBS aluminum wheels.

The car is accompanied by a binder of documentation, including Ford GT corporate literature, window sticker, certificate of authenticity, manuals, and air compressor.

With its stunning retro-inspired design and breathtaking power, the Ford GT has been a highly sought-after model since its release. This low-mileage example, with its rare exterior finish, is an excellent opportunity to own a genuine piece of Ford performance history.



1970 Plymouth Hemi 'Cuda

\$180,000 - \$225,000

CHASSIS NO. BS23R0B178859



3074

Offered from The RPM Collection

426 cu. in. Hemi V-8

TorqueFlite automatic transmission

Finished in Alpine White with black vinyl roof

Well optioned, with sleeper looks

The Chrysler E-Body didn't last long, but its short run was right in the middle of the muscle-car heyday. Unlike the Plymouth Barracuda and related Dodge Challenger that came before the E-Body, the new cars introduced for the 1970 model year stood on their own. They had muscular haunches, a low, sweeping roofline, and even an interior to match.

Of course, underhood thrust was crucial. Back in 1968 Plymouth first shoehorned the 426-cubic-inch Hemi V-8 under the hood of the last Barracuda largely as a Super Stock drag-racing experiment. The fifty cars built burned rubber in rapid fashion, and dealers and the public alike urged the Mopar crew to do it all over again, so of course the engineers in Detroit made sure the big





engine would slot right into the E-Body. Thanks in part to the hemispherical combustion chamber that gave it its nickname, the Hemi produced a hefty 425 SAE gross horsepower. Cars that rolled out of Chrysler assembly plants with the big engine underhood also received a toughened-up suspension and beefed-up construction to handle the extra power.

Finished in Alpine White, the 1970 Plymouth Hemi 'Cuda offered here gives few hints as to what's under its hood. Sure, keen observers will notice its Shaker hood and hood pins and, of course, the black Hemi "hockey" stripes that run from its door handles back over its rear haunches toward its taillights. Yet, with its black steel wheels and simple dog-dish hubcaps mounted on Goodyear Polyglas

GT tires, the car seems to blend into its surroundings. It's the definition of a sleeper, a car visible to only those in the know.

This Hemi 'Cuda presents in exceptional condition. Its white paint is shiny, and its black vinyl roof shows little evidence of use. Inside, the black vinyl bucket seats are separated by a console with woodgrain trim that houses the TorqueFlite three-speed automatic transmission, which shuttles power rearward. Its Rallye dashboard houses a full complement of gauges, and an AM radio rests below.

Subtly menacing, this example stands ready to terrorize the pavement once again.



1960 Chevrolet Corvette



3075

\$90,000 - \$110,000

283 cu. in. V-8; four-speed manual transmission

Consignor states engine is original to the car

Frame-off restoration completed in 2008

Three-times NCRS 'Top Flight' award winner - 2008, 2009, and 2010

Two-owner car; under previous ownership for 47-years

Finished in attractive white with silver coves

Red interior features clock, radio, heat and defrost



3077

1959 Chevrolet Corvette

\$80,000 - \$100,000

Offered from the Jim Mangione Collection

Built in "gasser" style

350 cubic-inch V8 with Weiland 671 Blower

Hedman Heads and Stahl Headers

Borg-Warner Super T10 4-Speed

Painted Damson Plum Firemist Acrylic Lacquer

Matching Hardtop

Burgundy Fabric Interior



3078

2014 Audi S7

\$25,000 - \$35,000 OFFERED WITHOUT RESERVE

420 hp, 4.0-liter twin-turbocharged V-8

Seven-speed dual-clutch semi-automatic transmission

Equipped with Audi's 'Drive Select' system

Utilizes air suspension, blind spot monitoring system, and power-folding mirrors

A luxurious, German grand tourer



3079

1953 Buick Skylark

\$110,000 - \$120,000

180 hp, 322 cu. in 'Fireball' V-8; automatic transmission
 Originally built for Mr. JJ Moyer as inscribed on horn
 1989 AACA Senior first place winner
 Frame-off restoration completed roughly 10 years ago
 Finished in Matador Red with white convertible top
 Power bench seat, windows, top, steering, and brakes
 Interior features Selectronic radio
 One of 1,690 produced for 1953



3080

2013 Porsche Cayenne Turbo

\$25,000 - \$30,000 OFFERED WITHOUT RESERVE

500 hp, 4.8-liter twin-turbo V-8
 Top-of-the-line Cayenne model
 Upholstered in two tone Inter Umber and Cream interior
 Features sport design package with side skirts
 Interior includes panoramic roof system, ventilated front seats, and white instrument dials
 Accentuated by walnut interior package
 Rides on aggressive 911 Turbo 20-inch wheels with arch extensions



3081

1963 Chevrolet Corvette

\$60,000 - \$70,000

V-8 engine; four-speed manual transmission
 Optioned with matching removable hardtop
 Features dash-mounted clock and AM/FM radio
 Equipped with aftermarket aluminum radiator



3083

2015 GMC Sierra 2500 Denali HD

\$30,000 - \$40,000 OFFERED WITHOUT RESERVE

6.6-liter turbocharged V-8 diesel

Allison six-speed automatic transmission

Equipped with Duramax Plus package

Fitted with aftermarket lift kit, tires, and wheels

Utilizes optional GMC vibrating safety seat and electronic driver assists



3084

1955 Chevrolet Bel Air Coupe

\$50,000 - \$60,000

V-8 engine; automatic transmission

Features optional continental kit

Interior features dash-mounted clock, AM/FM radio, and tissue dispenser

Power bench seat, windows, and brakes

External accessories include driver-side spotlight, dual exhausts, and wide whitewall tires



3085

2012 Porsche Panamera Turbo S

\$40,000 - \$50,000 OFFERED WITHOUT RESERVE

550 hp 4.8-liter twin-turbo V-8; seven-speed dual-clutch automatic

Stealth looking matte finish with black leather interior

Impressive options include carbon ceramic brakes, Burmester Surround Sound System, and adaptive cruise control

Further options include rear wiper, ventilated front seats, rear comfort seats, and leather steering column



3086

1962 Chevrolet Corvette 'Fuel-Injected'

\$65,000 - \$85,000 OFFERED WITHOUT RESERVE

360 hp, 327 cu. in. fuel-injected V-8 engine

Four-speed manual transmission

Restored example; owner states it retains original drivetrain

Hardtop and soft top included

Interior features clock and Wonderbar radio

One of 1,918 fitted with the fuel-injected engine for 1962



3087

1958 Pontiac Bonneville Custom Convertible

\$125,000 - \$150,000

Offered from the Jim Mangione Collection

370 cu. in. Tempest V-8; automatic transmission

Desirable first year of Bonneville production

Finished in Patina Ivory with Redwood Copper accents with white convertible top

Equipped with power windows, steering, and brakes

Features Safeguard Speedometer, clock, and Wonderbar radio

One of 3,096 produced for 1958



3089

1989 Porsche 911 Speedster

\$110,000 - \$130,000 OFFERED WITHOUT RESERVE

3.2-liter horizontally opposed six-cylinder engine

Five-speed manual transmission

Finished in Silver Metallic

Odometer displays less than 17,400 original miles

One of just 2,104 produced for 1989

Fitted with air conditioning and aftermarket Recaro seats

Accompanied by tool roll

Highly desirable, one-year-only 911 Speedster



3090

1957 Ford Fairlane 500 "White Pearl"

\$75,000 - \$100,000

John North's famous "White Pearl" custom

Beautifully preserved and incredibly original

Custom paint, pinstriping, and extensive body work from the 1950s

Fully chromed E-Code 312 V-8 engine

Still fitted with the in-dash TV

Countless awards and magazine features

A true piece of car customization history



3091

1977 Aston Martin V8 Series III

\$95,000 - \$111,000

390 hp 5.3-liter V-8; three-speed automatic transmission

Stunning unrestored original example

Finished in Cambridge Blue over Blue Connolly leather with Onslow Blue carpet

Features power windows, electric sunroof, air conditioning, and Blaupunkt radio

Accompanied by BMIHT certificate

1957 Chevrolet Corvette 'Big Brake & Airbox'



3092

\$400,000 - \$500,000

CHASSIS NO. E57S104321

Offered from the Jim Mangione Collection

Fuel-injected 283 cu. in. V-8

Equipped with "Airbox" cold-air intake and "Big Brake" package

Finished in Venetian Red with factory hardtop and painted coves



Chevrolet's first rework of the Corvette roadster pushed the 1956 model in a far more muscular direction than the European-inspired original. Round headlights appeared to lean forward, and the new chrome-lined coves behind the rear wheels and carried into the front doors gave it additional presence. The Corvette wasn't just about looks, either. Six-cylinder power became a thing of the past as Chevy took the new V-8 that had been optional in 1955 and made it standard for the new year.

For 1957 the V-8 grew even larger toward the beginning of the model year, expanding from 265 to 283 cubic inches of displacement, and a floor-shifted, close-ratio four-speed manual transmission was added to the options



air. The special “airbox” could only be had with the four-speed transmission and the Positraction rear end, and it brought with it a steering column-mounted, 8,000 rpm tachometer. Additionally, no radio was specified so that Chevy didn’t need to shield the ignition system and the spark plug wires could be relocated away from the exhaust manifolds.

Just 1,040 1957 Corvettes were built with fuel injection, and only 43 were ordered with the “airbox,” including this Venetian Red example fitted with a white

interior, body-color coves, and a hardtop. To help bring the conservatively rated fuel-injected engine to a halt, the car is also equipped with the “Big Brake” package that added upsized, finned brake drums with metallic linings and fender-mounted cooling vents, with which only 51 cars were optioned for 1957. With its beautiful presentation and the fact that it is equipped with two of the rarest options for 1958, this car will remain a sought-after example for any discerning Corvette enthusiast.

list for the first time. Racing successes such as wins at the 12-hour Sebring race and the SCCA B-production championship had made the Corvette into a proper “race on Sunday, sell on Monday” performance car, and Chevrolet began to realize that its sportiest model could also be a technological flagship. In the Corvette, Chevrolet debuted its new “Ram-Jet” mechanical fuel-injection system in two grades—a lower-compression system rated at 250 horsepower, and a high-compression setup that came in at 290 horsepower.

When it came to racing, legendary engineer Zora Arkus-Duntov’s team installed a special fiberglass intake plenum in the engine compartment that brought in cold



1958 Chevrolet Impala Sport Coupe

3093

\$80,000 - \$90,000



315 hp, 348 cu. in. Tri-Power V-8
 Three-speed column-shift transmission
 Wonderful newer restoration
 Utilizes stainless steel exhaust system with exhaust ports
 Rides on spinner hubcaps with wide whitewall tires
 Features dual antennas and modern-style retro radio

2017 Can-Am Maverick X3 Max XRS Turbo R

3094

\$4,000 - \$6,000

OFFERED WITHOUT RESERVE



152 hp, 899-cc turbocharged three-cylinder; continuously variable transmission
 Utilizes fully integrated intercooler
 Equipped with Fox Racing shocks
 Fitted with TTX suspension
 Makes use of fully welded chassis

1961 Chevrolet Corvette

\$110,000 - \$130,000

3095

270 hp, 283 cu. in. V-8 engine with dual-quad carburetors
 Four-speed manual transmission
 Beautifully restored example
 Believed to have been delivered as a 'Big Brake'
 Accompanied by factory hardtop
 Interior features clock and radio with cassette
 Rides on Firestone Deluxe Champion tires; factory hub caps



1938 Bantam Roadster

\$25,000 - \$35,000
 OFFERED WITHOUT RESERVE

3096

50 cu. in. inline four-cylinder engine
 Three-speed manual transmission
 AACA National First Prize Winner in 2008
 Lovely two-tone color combination
 Equipped with wind wings and driver's side wiper
 Features full set of weather gear
 One of just 512 roadsters built in 1938



1923 Duesenberg Model A Sport Touring

BY RUBAY



3097

\$200,000 - \$250,000

CHASSIS NO. 891

ENGINE NO. 1257

Original chassis, engine, and desirable sport touring coachwork

Formerly of the well-known Weber Collection

Auburn Cord Duesenberg (ACD)

Club Certified Category 1

Classic Car Club of America (CCCA) Full Classic

THE DUESENBERG MODEL A

In November 1920, at the New York salon at the Hotel Commodore, the Duesenberg Brothers, who had birthed numerous successful racing cars, finally put their own name on a passenger car of their own design.

The Model A was powered by a straight-eight of 260 cu. in. that was developed with a single overhead camshaft actuating two valves per cylinder, which was a result of the Duesenbergs' experience winning at Indianapolis. Producing 88 hp, it was mounted on a ladder-style chassis frame of rather conventional design and had a three-speed sliding-gear transmission and four-wheel hydraulic brakes, the latter of which was the Model A's real innovation—it was one of the first American automobiles to be so equipped. The Model A was swift and road-able—as close as any 1920s automobile ever came to being a “driver's car.”

Between 1921 and 1926, when it was purchased by E.L. Cord, the Duesenberg factory in Indianapolis produced some 500 Model As.

CHASSIS NUMBER 891

The early-style touring body for the Model A was produced by two coachbuilders, Millspaugh & Irish of Indianapolis, and Leon Rubay & Company of Cleveland, Ohio, the latter founded by a French stylist known for his rakish lines. Historian Fred Roe noted that about 75 examples of the touring were produced, some of which were the sport model with dual sidemounted spares, like the example offered here.

This Rubay-bodied sport touring originated from a Quaker State Duesenberg dealer and made it to Harold Jensen of Carmichael, Pennsylvania, by 1967. It was then sold to Ed Sackley of Skokie, Illinois, then in 1985 by Sackley's widow to Dave and Fred Weber of St. Louis. In a recent conversation, Dave Weber recounted that the car, when purchased, was in excellent original condition, including good original upholstery. It was restored in-house by the Webers in its present striking vermilion color scheme with Rudge-Whitworth chrome wire wheels and folding tonneau windshield. It remained part of their collection with other Duesenbergs and great Classics for several years. Late in the 1980s it was sold to the Blackhawk Collection of California and was exhibited there well into the 1990s. The current owners acquired it in 2003.

Well-preserved since restoration, this Model A is a wonderful example of Fred and August Duesenberg's superb engineering and a treasure for any ACD enthusiast's collection.



1955 Chevrolet Bel Air Convertible

\$55,000 - \$65,000



3098

V-8 engine; automatic transmission

Featured with AM radio, tissue dispenser,
and dash-mounted clock

Rides on wide whitewall tires

Utilizes dual exhaust



◆ 1933 Chrysler CL Imperial Dual-Windshield Phaeton BY LeBaron

\$225,000 - \$275,000
OFFERED WITHOUT RESERVE

CHASSIS NO. CL 1313
SERIAL NO. 7803613
BODY NO. 172-35



3099

One of fewer than 20 authentic survivors

Originally delivered to powerboat racer Lou Fageol

Formerly owned by Turhan Bey, Jack Passey, and Laurence "Baron" Dorcy

Well-known full history from new



This 1933 Chrysler CL Imperial Dual-Windshield Phaeton was bought new by racing boat legend Lou Fageol, "the world's fastest man on water." After about a year, Fageol had his shop fit the car with a 1930 Cadillac V-16 engine, no. 700132, along with associated adjustments to the chassis and suspension. With its V-16 fitted, the Fageol Imperial next passed to Hollywood film actor Turhan Bey and subsequently to a student at Stanford University, who sold it in the early 1950s to the late, legendary Northern California collector and enthusiast Jack Passey. Passey in turn traded the car to Earl Hill and Dick Wells, who sold it to Laurence Dorcy.

Better known to one and all by his favored nickname, Baron, Mr. Dorcy was the grandson of Great Northern Railroad magnate James J. Hill and lived the fabulous life of a millionaire eccentric. Over the next 50 years, he would come to own the Chrysler two further times, always buying it back after he sold it. Ken Daniel, a longtime friend and neighbor, was the last to sell the car to Dorcy, in trade for a Duesenberg in 2001, and reacquired it from Dorcy's estate 10 years later.

The Imperial was restored between 1985 and 1987 by Harold Orchard. More recently, during Baron Dorcy's final ownership, the car had the engine hood correctly replaced, and the body was refinished in its present

brilliant scarlet. Most recently it has undergone further cosmetic restoration and, somewhat poignantly, the installation of a period-correct CH Imperial engine, very similar to the original CL unit that first powered the car in 1933.

The car has been well-known to the Chrysler Imperial community for decades. It is described in Christopher Cummings' book *Cadillac V-16s: Lost and Found* and is pictured in *For the Love of Old Cars* by Ken Albert, a book on Jack Passey's automobiles. Furthermore, it is listed in the compendium of original CL Imperial phaetons published by George Tissen in 1980, further documenting its provenance as a genuine example.

Surviving CL Imperial dual-windshield phaetons are widely held as among the most beautiful and desirable American Classics. Few, however, have the rather spectacular, unlikely, and wonderful history of the example offered here, which has been owned and driven since new by utterly fascinating individuals and has accrued a lifetime of amazing stories. This car represents an excellent opportunity to enter into American Classic ownership with Chrysler's top-of-the-line model for 1933, the Imperial, one that set its sights on competing with the likes of Cadillac, Duesenberg, Pierce-Arrow, and Packard.

1958 Jaguar XK 150 Roadster



3100

\$90,000 - \$120,000

OFFERED WITHOUT RESERVE

CAR NO. S830667DN

ENGINE NO. V 4194-8

BODY NO. F15870

One of just 1,173 exported for 1958

Comprehensively restored and beautifully presented

Fitted with an exceptional burled wood dash

Jaguar Heritage Certificate in place



As the ultimate expression of Jaguar's XK series cars, the XK 150 continued to offer the spirited performance and luxurious appointments that Jaguar's customers had come to know and love about the cars from Coventry. Introduced in 1957, the XK 150 presented a plethora of changes from lessons learned by Jaguar engineers who made the XK 120 and XK 140 models. Jaguar offered their new car as a fixed-head coupe and drophead coupe when production began, but the most desirable body style, the roadster, wouldn't enter production until 1958.

The XK 150 was built with knowledge earned during the marque's brilliant competition career. Four-wheel disc brakes, an enlarged radiator opening, a revised cylinder head, and enhanced passenger room marked the most significant improvements. The racy low-cut door lines of the XK 120 and XK 140 were replaced with a slightly more conservative shape. The tried-and-true XK chassis remained but was now powered by an upgraded 3.4-litre twin-cam six-cylinder engine. Inside, all models received a padded dash top, softer and wider seats, and a windscreen that wrapped around the cockpit. By the time the XK 150 hit showroom floors, it was clear that Jaguar had a fantastic automobile on their hands, one that was full of British charm and sophistication.

Built 10 June 1958, the example offered here left the factory wearing highly attractive Cream paintwork over a Red Leather interior with a Fawn top. Comprehensively restored to this very color scheme in recent years by Jeff's Resurrections in Taylor, Texas, the paintwork, brightwork, and luxurious red leather interior with matching carpet appears to be nearly new. The engine bay also shows beautifully, with clean surfaces, shiny paint, and brightly polished chrome surfaces throughout. At the time of restoration, the car received a unique and highly attractive burled-wood dash in place of the usual leather panels, a classic and highly attractive touch. Included with the car is a Jaguar factory service manual, wheel hammer, and a selection of documents.

As the last of the fabled series of sporting Jaguars that started with the XK 120, the XK 150 represents the end of an era. XK 150s are noticeably more refined and sophisticated than their older siblings, and they are excellent automobiles for touring. Driven only sparingly since restoration, the car offered here will provide the new owner with an incredible driving experience even today, some 61 years after it was first introduced.

1936 Delahaye USA Duesenberg 'Maharaja' Speedster Replica

**3101****\$200,000 - \$225,000**

502 cu. in. 'Big Block' Chevrolet V-8; automatic transmission

Well-executed replica of 'Maharaja' Duesenberg

Majority of project assembled by Bad Donkey Hot Rods of Hanover, PA

Custom steel chassis built by Fat Man Fabrications of Mint Hill, NC

Equipped with air conditioning; power windows, steering, and disc brakes

1957 Chevrolet Bel Air Convertible

**3103****\$60,000 - \$65,000**

V-8 engine with four-barrel carburetor

Automatic transmission

Features white convertible top

Utilizes modern-style retro radio

1951 Crosley Hot Shot

\$10,000 - \$14,000
OFFERED WITHOUT RESERVE

26.5 hp, 44 cu. in. CIBA
four-cylinder engine

Warner three-speed
manual transmission

Benefits from twin carburetors
and finned valve cover

Equipped with aftermarket
exhaust system

One of just 2,498 built during
four-year production

3104



1973 Chevrolet Corvette Convertible

\$30,000 - \$40,000
OFFERED WITHOUT RESERVE

350 cu. in. V-8 engine; four-
speed manual transmission

Nicely restored example finished in
Blue-Green with removable hardtop

Equipped with optional
rear luggage rack

Interior is completed in Dark
Saddle with AM/FM radio

Equipped with air conditioning;
power windows and steering

Rides on Firestone thin whitewall bias
ply tires mounted on Rally wheels
with factory trim rings and hub caps

3105





1968 Chevrolet Corvette Stingray L88 Convertible

3106

\$475,000 - \$575,000

CHASSIS NO. 194678S411010

One of just 80 L88 Corvettes produced for 1968

Classic combination of British Green over saddle

Well-documented example

Restored by marque expert David Walters

The third-generation Chevrolet Corvette carried the seafaring theme of its predecessor into a new muscle-car era. Based on the Mako Shark II that General Motors paraded around in 1965, the new Corvette had far more pronounced wheel arches and a lower-slung shape than its predecessor. Coupes lost the sloping rear glass seen in the second-generation Corvette in favor of a smaller vertical pane ensconced by buttresses that sloped toward the Kamm-style tail. An optional hardtop for convertibles echoed the look.

Power underhood came from a host of small-block and big-block V-8s that started from a healthy 300 horsepower and rocketed skyward from there. After making a brief appearance as a competition engine in the last year of the outgoing body, Zora Arkus-Duntov ushered into production the L88 427-cubic-inch V-8. Officially Chevy denied that the engine could be ordered for street use and said it was intended for racing. That was the company line, at least. In reality 80 Corvettes fitted with the high-compression engine—far more powerful than its 430-horsepower



factory rating suggested—snuck out, only a pair of which were campaigned. The race-derived engine was the brainchild of Zora Arkus-Duntov and had earned its stripes in endurance challenges at Sebring and Daytona.

The new Corvette was slippery, fast, and was even praised by contemporary media for its handling prowess. With the L88 V-8 underhood, the Corvette could vault to 60 mph in an astounding 4.2 seconds and needed just four more seconds to reach triple digits. Just eighty 1968 Corvette L88s were built.

Finished in its classic factory-specified British Green Poly over a saddle vinyl interior, this 1968 Corvette convertible's visual elegance almost masks its underhood punch. Swing open its hood with its functional scoop, and the 427-cubic-inch L88 V-8—assembled in Tonawanda, New York, and fed by a Holley four-barrel carburetor—comes into view.

This well-documented example was delivered new to Harte Chevrolet in Meridian, Connecticut, optioned with hard and soft tops, rally wheels, and a mandatory radio and heater delete. It has remained under the careful watch of Corvette enthusiasts for five decades. The car was restored by David Walters and remains one of the finest extant.



2018 Ferrari California T 70th Anniversary

\$275,000 - \$325,000

CHASSIS NO. ZFF77XJA0J0229582



3109

70th Anniversary livery no. 42: the Daytona

Inspired by the 365 GTB/4 Cannonball winning car (chassis no. 1427)

Presented with less than 850 miles; single-owner example

Equipped with desirable handling package

Rare opportunity to acquire bespoke Tailor Made Ferrari

Accompanied with copy of window sticker

Eager to showcase the capabilities of its Tailor Made department, rather than produce a special, limited-edition model for its 70th anniversary, Ferrari instead decided to highlight some of its most interesting vehicles on the canvas of its current production models. Utilizing the F12, GTC/4 Lusso, California T, 488 GTB and 488 Spider as a basis, Ferrari designed 70 different and unique liveries, each to represent a model or individual car central to its history, from the earliest 125 to the 458 Speciale Aperta. Allowing the Tailor Made department to flex its muscles, Ferrari showed its clients that while the

next 70 years will certainly have lots to look forward to, it is not forgetting its past.

Of the 70 different liveries, the one worn by this California T is one of the later liveries, specifically 'the Daytona,' which celebrated the 1970 Ferrari 365 GTB/4. Externally, the car is painted in Blu NART with a matching hardtop. Its wing mirrors and front and rear skirting are finished in *Argento Nurburgring*. Inside, the dashboard and steering wheel are covered in black leather, while the seats and lower dashboard wear a high-quality Connolly *Rosso* leather with black Daytona inserts to mimic that





of the original. The carpets are also in Connolly *Rosso* and made of a material called mycroprestige, which was developed specifically for Ferrari and is soft to the touch. *Argento Nurburgring* aluminum trim can also be found on the shift paddles, upper dashboard, center console, and footrests, tying the exterior and interior together beautifully.

Further options on this car include painted "Alluminio" calipers, yellow Scuderia shields, and 20-inch forged, painted wheels. The car is also fitted with the extremely desirable handling package. With regards

to the interior, options such as the Cavalino stitched headrests, a yellow tachometer, full electric seats, and leather headline finished in Nero black make the car absolutely spectacular in its appearance. When delivered new, it featured an MSRP valued at just over \$364,000, a deserving price for such a bespoke car with over \$161,000 in options.

Delivered new to its first and only owner through Classic Car Imports LLC of Palm Harbor, FL, this particular car has only traveled less than 850 miles and remains in virtually as-new condition throughout. The California

Ts boasting 70th Anniversary liveries remain the most desirable examples of their breed, celebrating the race-bred nature of the brand while remaining comfortable and practical enough to be used on a daily basis. This one-off California celebrating the Cannonball-winning 365 GTB/4 would be an exciting addition to any collection.



1962 Triumph TR3B



3110

\$20,000 - \$30,000
OFFERED WITHOUT RESERVE

Inline four-cylinder engine
with dual SU carburetors

Manual transmission

Originally sold through Standard
Triumph Motor Company
Inc. of Houston, Texas

Sharp color combination,
finished in white over black

Rides on Michelin tires mounted
on knock-off wire wheels

Accompanied by BMIHT certificate

1972 Chevrolet Corvette Convertible



3112

\$36,000 - \$42,000

L82 382 cu. in. V-8; automatic
transmission

Finished in attractive sea mist
green over black with a black top

Power windows, steering, brakes

Fitted with air conditioning

1968 Chevrolet Camaro SS 396 Convertible



3113

\$42,000 - \$48,000

396 cu. in. V-8 engine; four-speed manual transmission

Finished in attractive Matador Red with front black accent band

Equipped with power steering and brakes

Interior features bucket seats, radio, and console with accessory gauges

Other options include dual sideview mirrors, wood-grain dash, and desirable teak steering wheel

Rides on Rally Wheels with BFGoodrich Radial T/A tires

Wonderful example of the highly desirable SS 396 Convertible



1969 Chevrolet Corvette Stingray L88 Convertible

**3116****\$475,000 - \$575,000**

CHASSIS NO. 194679S704899

Offered from the Jim Mangione Collection
L88 430 hp, 427 cu. in. V-8; one of only 116
M22 four-speed manual transmission
Tuxedo Black over saddle leather
upholstery with tan soft top
Highly desirable last year of the L88

All it took was ticking the right option boxes to transform a 1969 Corvette Stingray from a boulevardier into a ferocious performer. It would be a disservice to say that the handful of 1969 Chevrolet Corvettes ordered from the factory with the race-derived L88 427-cubic-inch V-8 were accidental, of course. Those future Corvette owners who specified the ultra-high compression big-block engine with its aluminum heads, high-capacity four-barrel carburetor, bespoke induction, and domed hood knew exactly what they were getting into.





What they may not have known was that 1969 would be the final year for the engine that had proven itself on the track. Officially, the engineers, lawyers, and product planners at General Motors specified that the L88 engine was for track use, but it was street legal and ran on standard pump fuel. Chevy rated the engine at 430 horsepower, a very conservative figure for an engine that really put out closer to 600 horsepower, and didn't bother to advertise its existence in its contemporary marketing material. The L88 debuted for the 1967 model year and required those dealers willing



to order one to jump through a few hoops. Dealers first had to select the performance suspension, positraction rear differential, and the biggest brakes available to handle an engine capable of vaulting the Corvette from a standstill to a quarter of a mile in less than 12 seconds. A radio and an air conditioner were not available. The engine was meant for track use, after all.

At \$1,032.15 on top of the convertible's base price, the option was neither for the faint of heart nor the light of wallet. Of course, few L88 Corvettes found their way to racetracks. Most instead were relatively loaded up as coupes or convertibles, and they terrorized late-1960s pavement.

This 1969 Corvette L88 Convertible, with its color combination of Tuxedo Black over saddle leather upholstery, is well-known in the Corvette community and is an eminently drivable example. The car presents well, and it retains special-order charms such as a radio-delete blank plate, a chrome knob for its M22 four-speed manual gearbox, and the L88-specific hood. Only 116 examples of the L88 were built for the final year of one of the most legendary motors ever put in a Corvette. This fine example represents a unique opportunity to enter into ownership of one of the rarest and most desirable Corvettes, the L88.



1937 Cord 812 Phaeton



3118

\$130,000 - \$160,000

CHASSIS NO. 32010A

Timeless Gordon Buehrig design

Legendary performance

Fully restored in the late 1990s

CCCA Full Classic

Sometimes known as the “Baby Duesenberg” and produced only for 1936 and 1937 before the ultimate demise of E.L. Cord’s massive automotive and industrial empire, the innovative Cord 812 Phaeton offered here remains an undisputed collector favorite today. Conceived as the eventual successor to the groundbreaking and handsome but short-lived front-drive Cord L-29 of 1929, the later 810/812 series continued to exemplify company president E.L. Cord’s proven formula for sales success: a combination of cutting-edge styling and high performance, all at a surprisingly reasonable price point.

Again fitted with an advanced front-wheel drivetrain, the new 812 offered a 288-cubic-inch V-8 engine from Lycoming, one of Cord’s many companies, mated to an innovative four-speed, electrically shifted pre-selector transmission. The smooth Gordon Buehrig-designed body was an equally major step forward in automotive design, featuring a blunt louvered “coffin” hood, retractable headlights, and the absence of running boards. Its reception at the November 1935 New York Auto Show was enthusiastic, and orders poured in. Alas, production startup was slow, and by the time supply finally caught up with demand, some customers had changed their minds.



All in all, some 2,900 examples were built, 612 of those being phaetons.

The car being offered here is said to have been restored some years ago by noted restoration experts Al Prueitt and Sons of Glen Rock, Pennsylvania. It is painted correct Cigarette Cream with dark burgundy upholstery, a superb and truly classic color combination. It is fitted with a newer convertible top. This Cord is equipped with engine number FB 2003 and affixed with body number tag C 91 417; it appears to be original and is believed to have been born with the current engine and as a phaeton. However, the serial number tag has been replaced at some point and may have been erroneously stamped with the number of a supercharged Westchester Sedan. Furthermore, Cord historian Josh Malks's books on the subject indicate that engine FB 2003 is fitted to an unspecified, un-supercharged phaeton, as this car is.

Of the 612 convertible phaetons, this car is certainly among the most attractive, and as a CCCA Full Classic, it's the perfect candidate for CARavans and judged shows. With just 1,524 miles showing on the odometer, it is sure to offer many more miles of enjoyment to its fortunate new owner.



1947 Ford Super Deluxe Convertible

**3119**

\$30,000 - \$35,000
OFFERED WITHOUT RESERVE

21-stud flathead V-8 engine

Three-speed column-shift
manual transmission

Beautifully restored example

Finished in maroon with a
tan convertible top

Interior features wood grain
dash, clock, and heater

Aftermarket turn signal switch installed

Rides on whitewall bias ply tires;
stainless trim rings and hub caps

1963 Chevrolet Corvette Sting Ray 'Split-Window' Coupe

**3120**

\$85,000 - \$100,000

327 cu. in. V-8 engine; four-
speed manual transmission

Iconic one-year-only design

Finished in Sebring Silver

Power windows, steering, and brakes

Interior features clock and radio

2017 Ford Shelby GT350 R

\$70,000 - \$80,000
OFFERED WITHOUT RESERVE



3121

526 hp, 5.2-liter V-8 engine; six-speed manual transmission

Finished in Lightning Blue with White stripes with Red accent

One of only 43 GT350Rs delivered in this color combination for 2017

Equipped with Track Package and Electronics Package

Features Recaro bucket seats and navigation system with SYNC 3

Accompanied by owner's manuals and wheel lock tool

Less than 300 miles from new



1967 Chevrolet Corvette Sting Ray COPO Convertible

3122
\$650,000 - \$850,000

CHASSIS NO. 194677S117714

Custom-ordered by Bill Mitchell for his wife

400 hp, 427-cubic-inch V-8

Bespoke white-and-red accents

Exceptionally well documented

The first Bloomington Gold Historic Award recipient

Long gone are the days of à la carte options for most new cars. Back in Detroit's heyday, however, General Motors allowed its dealers to pick and choose how they wanted to build the cars headed to their showrooms. Certainly there were some limitations and probably a few phone calls from Detroit to little dealers scattered across the country questioning their intentions, but ultimately there was only modest oversight.

GM cars tagged with four innocuous letters—COPD, for Central Order Production Office—were intended to be custom orders for budget-conscious municipal fleets eager to delete as many options as possible. Even legendary GM designer Bill Mitchell made use of the COPD program to pick and choose features for a special Ermine White 1967 Chevrolet Corvette Sting Ray Convertible he presented as a gift to his wife, Marian. Working with instructions handwritten by Zora Duntov himself, Mitchell set to work on custom-ordering his latest company car, only this one would not merely end up in the company car park wedged next to Impalas and Novas.





After selecting the Big Block Tri-Power 427-cubic-inch, 400-horsepower V-8 paired to a heavy-duty version of the PowerGlide automatic transmission and a 3.08 Positraction rear differential, Mitchell loaded on the luxuries, including power windows, telescoping steering column, air-conditioning, and AM/FM radio. Power steering and brakes helped tame the beast underhood. More than nearly anyone else, Mitchell knew that 1967 would be the last year for the third-generation Corvette, and so he planned a proper going-away gift for the design he had first sketched out as the Sting Ray Racer concept car more than a decade before.

After being inspired by an encounter with a shark in the Bahamas, Mitchell created a car that was predatory in every way. That showpiece had been designed as a tribute to the division's racing efforts, as the Automobile Manufacturers Association pulled the curtain on factory-backed competition. The production Corvette bowed for 1963 and advanced the roadster's design considerably with bold lines, pop-up headlights, and even a coupe configuration.



For Mitchell, however, it would be the classic roadster design that drew his attention on the eve of third-generation Corvette production. After placing the order that had been blessed by Duntov himself, Mitchell reportedly walked along the St. Louis, Missouri, manufacturing line where Marian's 1967 Sting Ray was assembled to ensure that it would be without flaw. From there the car was shipped not to a Chevrolet dealer but to the General Motors Technical Center in Warren, Michigan, where Mitchell put his characteristic touch into it to make it stand out from the crowd. He applied red accents to the car, most notably extending the "stinger" graphic past the passenger compartment and over the trunk lid and into the rear valance. The "stinger" stripe frames the license plate perfectly, a reminder of the design's remarkable continuity.

Marian is said to have enjoyed the car for two years. It drew looks even after the fourth-generation Corvette became a common sight on American roads, especially around Detroit. Instead of merely trading it in for another company car, the Mitchells eventually sold it to neighbor Harry Byrd, who passed it farther down their suburban Detroit block to Richard Brown. It was Brown who would move it out of Michigan when he retired to sunny Florida and eventually sold it to Don Newton in Kentucky.

While undertaking a restoration, Newton discovered a build sticker with relevant option codes, including one that undoubtedly caused some anxiety in the line worker who applied it: "W Mitchell" was a special typed addition to the option list.

This exceptionally well-documented example counts among its numerous accolades the first Bloomington Gold Historic Award, which was bestowed upon the white-and-red roadster in 2001.





1960 Chrysler 300F Coupe

**3123****\$60,000 - \$75,000**

365 hp, 413 cu. in. V-8 engine

Push-button automatic transmission

One of only 964 300F Coupes produced for 1960

Fitted with factory bucket seats with
full-length center console

Equipped power windows, steering and brakes

Rides on whitewall tires with factory wheel covers



1969 Jaguar E-Type Series 2 4.2-Litre Roadster

\$70,000 - \$80,000



3124

Showing less than 24,000 miles; believed to be original
 Older excellent restoration by RM Auto Restorations
 Scored 991.7/1000 in 2017, JCNA judging sheet included
 Upgraded with triple Weber carburetor and intake
 Recent tune-up and restored braking system and suspension
 Includes Jaguar Heritage certificate

Jaguar debuted the second series E-Type in 1968. Federal regulations in the United States, Jaguar's most lucrative market, drove some of the changes, including revised lighting and the shift to a pair of Stromberg carburetors in place of the three SU units of earlier E-Types. Externally, the air intake was substantially increased in size, a change masked by larger, full-width bumpers that were matched at the rear to meet the U.S. low-speed impact requirements.

The well-proven 4.2-liter inline six-cylinder XK engine was little changed, although a higher-capacity water pump was fitted, taking advantage of the enlarged radiator air intake and better adapting the E-Type to warmer climates. The car was equipped with bigger Girling brakes with three-piston calipers at the front and two-piston calipers at the rear, while the interior

now featured reclining seats as standard equipment. In short, the evolution of the E-Type meant that buyers of the Series 2 got a much better, more comfortable, and more reliable Jaguar—attributes that complemented its already well-established reputation for superior performance, handling, and looks.

This beautiful 1969 4.2-Litre roadster was restored some years ago by RM Auto Restorations. It has been meticulously maintained since and driven roughly 1,000 miles, used exclusively for shows. In 2017, the car was judged at a Jaguar Club North America event where it scored an impressive 991.7 out of 1,000 possible points.

A six-point deduction for not having horns has since been alleviated, with fully functional horns installed. Given the improvement, the car would presumably score closer to that perfect 1,000-point mark. The car was recently mechanically sorted, which included a tune up; as well as a restoration of the braking and suspension systems.

The E-Type is arguably the most iconic road-going car Jaguar ever produced. This example, having been judged to a very high standard by marque experts and more recently benefitted from a mechanical sorting, is sure to impress future owners for years to come.



1971 Ferrari 365 GTB/4 Daytona Berlinetta BY SCAGLIETTI



3125

\$525,000 - \$625,000

CHASSIS NO. 14769

Sold new through Harrah's Modern
Classic Motors in Reno, Nevada

Documented by marque historian Marcel Massini

Accompanied by tool roll and
owner's manuals in pouch

One of 1,284 Berlinettas built from 1968-1973

The 365 GTB/4 that debuted at the Paris Motor Show in the fall of 1968 marked a great departure from the 275 GTB that preceded it. With its long hood and hidden headlights covered initially by Perspex and later reworked as retractable units to satisfy U.S. federal requirements, the GTB/4 became the quintessential Italian long-distance grand-touring car design. Underneath, it utilized a welded tubular steel frame, an independent suspension, and a new version of the V-12 complete with four chain-driven camshafts and six downdraft Weber carburetors. At 352 hp, the 365 GTB/4 boasted two more horses than the Miura, a point hardly lost on engineers in Sant'Agata.

The motoring press dubbed the supercar Daytona, a nickname that stuck with engineers and designers but not marketers in Maranello; Ferrari rarely refers to the car as anything other than the 365 GTB/4. The Scaglietti-bodied 365 GTB/4 Daytona went into





production in 1969 and spawned a convertible spider the next year at the Frankfurt salon.

This 1971 Ferrari 365 GTB/4 Daytona Berlinetta was completed by Ferrari on 2 December 1971, and according to marque historian Marcel Massini, it was finished in *Bianco Polo* (20-W-152) over a *Nero* (VM 8500) leather interior to U.S. specifications, with left-hand drive and fitted with air-conditioning. Later that month it was shipped to the United States and delivered to Bill Harrah's Ferrari distributorship, Modern Classic Motors, in Reno, Nevada.

On 19 April 1972, the car was sold new to its first private owner, Gary MacLeod of Medina, Washington. Following its departure from MacLeod's ownership, it resided with a noted Ferrari collector who was based in North Carolina. During this time the car was repainted from white to silver metallic gray. By 1996 the car was owned by William S. Ferguson of Albuquerque, New Mexico, who had the car painted its current shade of red. The car



passed from Ferguson to Earl Whittemore of Los Lunas, New Mexico, in November 1999, subsequently becoming a part of two prominent collections, first in Texas, then in Ohio. The current ownership purchased the car in 2016, over which time the car has covered roughly 2,000 miles.

The mid-'90s repaint has held up very nicely. The interior is completed in a rich black leather; it features power windows, air-conditioning, Veglia Borletti instrumentation, and a Becker Mexico AM/FM radio with cassette. The Daytona's black leather interior remains in beautiful condition. The car currently rides on Borrani knockoff wire wheels fitted with Michelin XWX radial tires. Additional exterior features include a driver side-view mirror, power antenna, and ANSA exhaust tips. Under current ownership the car has received a full A/C service. The Ferrari is accompanied by its tool roll, as well as a set of owner's manuals in their leather pouch and select service records going back to the mid-1970s.

Arguably one of the most iconic road-going Ferraris, the Daytona remains a staple that should be a part of any prominent collection.







3126

1984 Mercedes-Benz 300 D Turbo Diesel

\$25,000 - \$30,000 OFFERED WITHOUT RESERVE

3.0-liter inline five-cylinder turbo-diesel engine; automatic transmission

Finished in Silver Blue Metallic with Blue MB Tex interior

Sold through Autohaus Brugger in Redwood City, CA

Power windows, mirrors, antenna, sunroof, steering, and brakes

Interior features Becker Grand Prix radio with cassette

Rides on Dunlop tires; factory wheels

Accompanied by window sticker, manuals, first aid kit, and tool roll



3127

1968 Chevrolet Corvette Stingray 427 Nickey Coupe

\$80,000 - \$100,000

Modified and sold new through the famous Nickey Chevrolet of Chicago

435 hp, 427 cu. in. V-8 engine; Muncie M21 close ratio four-speed manual transmission

Owner states car retains original numbers matching drivetrain

Nickey installed Hooker Headers side exhaust system

4.11 Positraction rear end gears

New Al Knoch Blue interior with AM/FM radio

Original vintage T-70 Torque Thrust wheels; Firestone redline tires

NCRS certificate, MCAACN Concours Gold winner, registered and certified by The Nickey Registry, Inc.



3128

1931 Ford Model A Coupe

\$20,000 - \$25,000 OFFERED WITHOUT RESERVE

40 hp, 201 cu. in. inline four-cylinder engine

Three-speed manual transmission

Finished in Chicle Drab and Copra Drab with Straw pin striping

Attractive Rumble Seat Coupe

Well-presented older restoration



3129

1987 Mercedes-Benz 560 SL

\$20,000 - \$25,000 OFFERED WITHOUT RESERVE

5.6-liter V-8 engine; automatic transmission

Odometer displays less than 2,600 miles; believed to be original

Equipped with air conditioning, power windows, and an AM/FM radio with cassette

Rides on Michelin radial tires

Accompanied by manuals and tool roll

An excellent example of the 560 SL

1936 Cord 810 Phaeton

\$140,000 - \$170,000

SERIAL NO. 810 2361 H

ENGINE NO. FB 1632

BODY NO. C 91680



3130

ACD Certified Category 1 (C-009)

Originally delivered in Pennsylvania; equipped with its original engine

Long-term ownership by noted enthusiasts and collectors

A superb Classic Car Club of America (CCCA) CARavan and Auburn Cord Duesenberg (ACD Club) tour car



When the “new Cord” made its debut at the New York Auto Show in November 1935, it turned the automotive world on its ear. Onlookers reportedly stood on the roofs of other cars just to catch a glimpse of Gordon Buehrig’s stunningly advanced “new, original, and ornamental design for an automobile,” with its aerodynamic “coffin-nose” louvered hood lacking a traditional radiator shell; its “step-down” floor; its unitary body construction; its hidden door hinges; its pop-up headlamps; and its total lack of running boards. Underneath was no less innovative, with a Lycoming V-8 running the front wheels through a four-speed, electrically shifted pre-selector transmission, which was operated by a “key” off the steering column; essentially, it was an H-pattern gearshift in miniature.

Orders for the new Cord flooded the manufacturer’s headquarters in Auburn, Indiana, but the car was not quite ready for production. By the time cars finally began to be delivered, many impatient customers had canceled their orders, and the car that could have saved the Auburn Automobile Company became its death knell. The new Cord was only built for two years, and it has since gone down in history as one of the most beautiful automobiles of its time, being regularly displayed in art museums as what Buehrig referred to as “rolling sculpture.”

The 810 Phaeton offered here was originally delivered in Pennsylvania, where it was first registered on 11 June 1936. An interesting notation in its Auburn Cord Duesenberg Club paperwork is that it was once owned by Richard Nicholas, whose home was the famous Stonebridge estate

in Chadd’s Ford. The car remained in the Quaker State for its first 35 years, including ownership by the well-known enthusiast and CCCA member Calvin High. Mr. High sold the car in 1971 to Frank Martucci, the mayor of Roslyn Heights, New York, a skilled acrobatic pilot and Cord collector who retained it until the early 2000s.

In Mr. Martucci’s long-term ownership, the already freshly restored car was again restored to meet his standards, in the present Cigarette Cream with dark red interior, an original available factory color combination, while adding 1937-style side exhausts. He submitted it to the Auburn Cord Duesenberg Club, where it was fully certified as a Category 1 Original Car—only the ninth Cord to be so recognized. Among its honors in his ownership was an AACA Senior First Prize, reportedly with 397 out of a possible 400 points, and Senior awards in ACD Club national judging.

The current ownership purchased the car in 2016. Since then it has been shown at numerous events and has been mechanically maintained, most recently receiving a new convertible top. It is still a beautiful machine, ideal for both CCCA CARavans and ACD Club tours, as well as regional concours d’elegance—allowing its new owner to experience one of the most striking and well-engineered automobiles of its time.

1977 Aston Martin V8 Vantage 'Bolt-On Fliptail'

3131
\$175,000 - \$250,000

 CHASSIS NO. V8/11704/RCAV
 ENGINE NO. V/540/1704V

One of just 16 'Bolt-On Fliptail' V8 Vantages built

 Matching-numbers Vantage-spec V-8
 engine and five-speed gearbox

 Professionally converted to LHD
 during full mechanical rebuild

To Aston Martin enthusiasts, the name "Vantage" refers to models that have been ordered with an uprated engine—an option that began with the DB2. However, when the V8 Vantage was unveiled in 1977, the Vantage was offered as a distinct model from the V8 Saloon that had come before it, with unique styling in addition to its high-performance upgrades. Rightly dubbed Britain's first supercar, it was powered by an incredible 390-horsepower V-8 engine, capable of pushing the car from zero to 60 mph in just 5.2 seconds on its way to a top speed of 170 mph. These are solid numbers, even today, and were truly groundbreaking for the late 1970s. It was the fastest production road car of its day, faster even than the vaunted Countach, 512 BB, and 911 Turbo.





No mere performance machine, the Vantage was equally valued for its tough good looks. The Vantage retained much of the same look as the Saloon, with the addition of some aerodynamic elements, including a molded front air dam, modified hood, and a “fliptail” rear end that was added to reduce lift and drag. After the first 16 V8 Vantages were produced, Aston Martin made a subtle change—instead of bolting on these spoilers post-production, the remaining 23 cars were made with an integrated or ‘Molded Fliptail,’ making the original ‘Bolt-On Fliptail’ cars the rarest version of the V8 Vantage.

The car offered here is one of those first 16 ‘Bolt-On Fliptail’ Vantages. It is particularly desirable, as it is a matching-numbers example with factory five-speed

manual gearbox. Originally an RHD car from the UK, this example was professionally converted to LHD during a three-and-a-half-year restoration by RSP Motorsports of Komoka, Ontario, Canada, during which time a new interior was installed and the car was repainted from Red to the classic Aston Martin shade of Silver.

This stunning Vantage is an ideal example for spirited driving. With its powerful acceleration, exceptional top speed, and stunning good looks to match, this rare Aston Martin is sure to turn heads wherever it goes, especially among those who recognize the car’s significance. This is an extraordinary opportunity to acquire one of the rarest examples of Aston Martin’s first supercar.

1966 Land Rover Series IIA 88

\$100,000 - \$150,000

CHASSIS NO. 31600162C



3133

Formerly owned by His Holiness, the 14th Dalai Lama
 Maintained in the Dalai Lama's family until 2005
 Fully restored in 2006, documentation included
 British Motor Industry Heritage Trust Certificate
 Extensive original documentation

When the Land Rover debuted at the 1948 Amsterdam Auto Show, it set the mold for commercial off-road vehicles for decades to come. Then powered by the 1,595 cc inline-four from the Rover 60 automobile, the Land Rover initially had a boxy alloy body with its narrow-set headlights and wire mesh grille and was only available as a compact pickup. By 1949 it was joined by a wagon,

which eventually saw the brunt of production. Extended wheelbase and four-door models were introduced in 1955 and 1956, respectively. With the introduction of the new Series II in 1958, the Land Rover became even more capable and would soon make its mark in tough terrain all across the world.

The 1966 Land Rover Series IIA offered here was once owned by His Holiness, the 14th Dalai Lama. Built on the 88-inch-wheelbase chassis, it was completed on 10 February 1966 and was delivered new to Nepal on 17 February 1966. It was then driven by His Holiness's brother, Tenzin Cheogyal, into India, where it entered service as His Holiness's official vehicle. Mostly driven by Tenzin Cheogyal to ferry his brother along the mountainous roads of the Dharamsala region of India, the Land Rover saw hard use for many years as His Holiness continued his work while in exile from Tibet. Today, the Land Rover is accompanied by original parts, including original seats, interior parts, and the original tires, all saved during the restoration.

After some 10 years in official service in Dharamsala, the truck was maintained by Tenzin Cheogyal until June of 2005. It was then donated to the Dalai Lama Foundation in Palo Alto, California, with the goal of raising funds for Tibetan refugees, arriving in the United States in



December of 2005. It was then fully restored by Land Rover experts in Livermore, California, with work concluding in December of 2006. Invoices totaling more than \$49,000 are included in the sale. It is presented today in beautiful condition and wears the classic Bronze Green paint scheme with which it left the factory back in 1966.

The Land Rover is accompanied by extensive documentation, including the British Motor Industry Heritage Trust Certificate, Haynes Land Rover Series II Owner's Workshop Manual with Tenzin Cheogyal's signature inside the first page, original license plate still on the vehicle, Indian titles and insurance policies listing His Holiness as the owner, paperwork surrounding its donation to the Dalai Lama Foundation in 2005, and copies of assorted photographs and articles.

In December of 2007, it was featured as the cover car for "Land Rover Lifestyle" magazine, in which they named it one of the six best Land Rovers in the United States with an extensive cover story. A copy of this magazine accompanies the vehicle. For Land Rover aficionados, the combination of a late Series IIA along with incomparable historical significance makes this a very unique opportunity to own a truly special car.

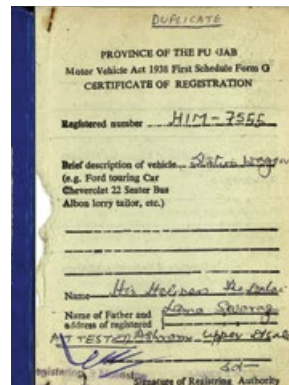
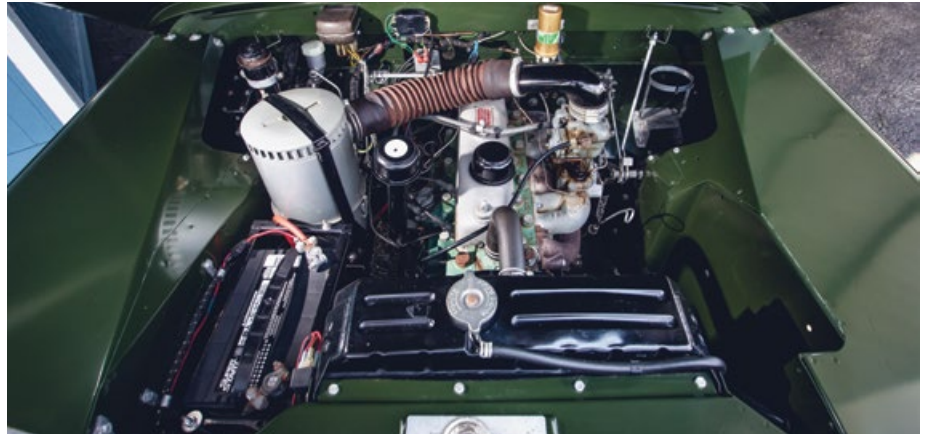



1953 Chevrolet Corvette

3136

\$180,000 - \$220,000

OFFERED WITHOUT RESERVE

CHASSIS NO. E53F001214

The 214th of only 300 built
Recently completed service
Desirable first year of America's sports car

In the early 1950s, a team of GM engineers headed up by Harley Earl went to work on creating a fiberglass-bodied car that had the power and appeal to compete with European sports cars. Harley Earl had excelled at swooping designs since the 1920s and incorporated aircraft-looking features into the car, including round dials blended into a curved dash, all of which were sheltered under a roofline that stood just under 47 inches tall. The six-cylinder engine was positioned farther toward the rear, which gave the flat hood a long, sleek appearance.

This sports car, dubbed the Corvette "Dream Car," debuted at the GM Motorama show, which was held at the stylish Waldorf-Astoria Hotel in New York City, and it achieved astounding results. Following the first weekend of the Motorama event in New York, over 300,000 people had seen the car and spent \$800,000 on GM products. At the conclusion of Motorama's U.S. tour, GM claimed that over four million people had seen the car.

Production of the two-seat roadster started in June 1953, and by year's end a total of 300 Corvettes rolled off the assembly line. This first year of Corvette production



signified an important technical milestone: GM was the first major American car manufacturer to successfully mass-produce a vehicle whose underpan and body shell were made entirely of fiberglass.

The Corvette featured GM's 235-cubic-inch "Blue Flame" inline-six engine breathing through triple Carter carburetors and a dual exhaust. The engine's respectable 150 horsepower was transmitted to the road via a two-speed Powerglide automatic transmission. All 300 were visually identical—finished in Polo White with a Sportsman Red interior.

The Corvette offered here is the 214th example, produced in 1953. The previous caretaker owned the Corvette since 1980, and under his tenure it was restored in the early 1990s. Acquired by the current owner in 2016, the Corvette has seen little use and has subsequently

been stored in a climate-controlled garage. The car was serviced recently, including extensive work to the fuel system as well as rebuilding the fuel pump. A correct 1953 distributor was sourced and a new tachometer cable installed. The front end was loose and repaired accordingly, while both rear wheel bearings were replaced. Furthermore, the carburetors were cleaned and rebuilt as needed, the intake and exhaust valves were properly adjusted, and the exhaust system was also adjusted for correct fitment. Finally, several minor electrical issues were sorted and repaired.

This first-year Corvette is nicely presented and recently serviced. As no Corvette collection is complete without an original '53 model, the enthusiast seeking such a car need look no further than this fine example of America's sports car.

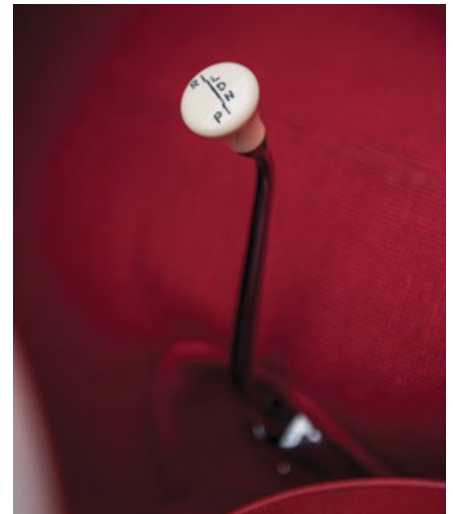

1972 Jaguar E-Type Series 3 V-12 Roadster



3137

\$80,000 - \$100,000

5.3-liter V-12; four-speed manual transmission

Finished in Light Blue with a black top and Dark Blue interior

Matching hardtop included

Fitted with chrome wire wheels and thin white-wall tires

Factory air conditioning; power brakes and steering

Accompanied JDHT certificate and Jaguar Owner's Club award

1954 MG TF Roadster



3138

\$25,000 - \$30,000

OFFERED WITHOUT RESERVE

Inline four-cylinder engine featuring twin SU carburetors

Four-speed manual transmission

Fully restored in 2000; invoices and restoration notes included

Finished in the correct Black over Red

Retains matching numbers engine

Equipped with Lucas fog lights

Rides radial tires mounted on painted knock-off wire wheels

Accompanied by BMIHT certificate

1969 Shelby GT350 Fastback

\$70,000 - \$90,000

CHASSIS NO. 9F02M480702



3139

351 cu. in. V-8; automatic transmission

Finished in the beautiful shade of Gulfstream Aqua

One of only 74 Shelby Fastbacks with these paint/trim codes for 1969

Originally sold through Horn and Williams MTR Co of Dallas, Texas

Fitted with air conditioning; power steering and front disc brakes

Retains original upholstery; Sport Deck rear seat

Elite Marti Report included



2017 Ford GT



3140

\$1,200,000 - \$1,500,000

CHASSIS NO. 2FAGP9CW8HH200040

SERIAL NO. H040

647-horsepower, 3.5-liter twin-turbocharged V-6

Seven-speed dual-clutch transmission

Believed to be the only 2017 example finished in Riviera Blue

Desirable serial number H040 in homage to its GT40 heritage

Believed to be the only road model released by the factory without rear NVH panel, exposing carbon-fiber tub

With Ferrari in its sights after a failed takeover bid, the Ford Motor Company, under Henry Ford II, assembled the world's best drive's and car builders in an effort to dominate global long-distance sports-car racing in the mid-1960s. The GT40 that bowed in May 1964 at the Nürburgring 1000 KM was the culmination of Ford's project. Based on the mid-engined Lola Mk 6, the GT40 had a thumping American Ford V-8 heart and would go on to win the 24 Hours of Le Mans an incredible four consecutive years between 1966 and 1969.

Over 30 years later, Ford found itself gearing up to celebrate its 100th anniversary, and it turned to designer Camilo Pardo to recreate the magic of the GT40. The concept car that debuted at the 2002 North American International Auto Show in Detroit whet the consumer appetite for a full road-going revival developed with Carroll Shelby's insight. Just over 4,000 examples of the supercharged V-8-powered car that largely kept to the original 1960s concept were built during a





two-year production run. After the last reborn Ford GT rolled out of the Wixom, Michigan, assembly plant, it seemed as if Ford was done with mid-engined supercars.

At the 2015 Detroit show, however, Ford stunned gathered media and enthusiasts across the world with the new Ford GT. This rakish sports car stuck to the mid-engined formula but now featured a 647-horsepower version of the automaker's twin-turbocharged 3.5-liter EcoBoost V-6 engine, which came paired this time with a seven-speed dual-clutch transmission supplied by Getrag.

The powertrain is capable of catapulting the car to 60 mph in less than three seconds and a top speed of 216 mph. Not just anyone could saunter into a Ford dealer and place an order, however. The automaker required those interested to apply for ownership and mandated that they keep their cars for an extended period. Ford plans to produce roughly 1,350 of these supercars through 2022.



This 2017 Ford GT was special-ordered through Pat Milliken Ford of Redwood Township, Michigan. The GT offers the uniquely desirable serial number H040 in homage to its GT40 heritage. In its short life, the car has covered less than 2,900 miles. This example is finished in Ford's Extended Color Palette 2, a \$30,000 option. Painted Riviera Blue, it is believed to be the only 2017 GT finished as such and is accented beautifully by the exterior gloss carbon-fiber package, a \$15,000 option. The GT rides on 20-inch gloss exposed carbon-fiber wheels wrapped with Michelin Pilot Sport Cup 2 tires. They are held on by titanium lug nuts and brought to a stop by Silver brake calipers, all optional equipment which added another \$15,000, \$1,000, and \$1,000, respectively, to the car's price tag. This Ford GT is believed to be the only road car released from the factory without the NVH panel affixed to the rear bulkhead, exposing the carbon-fiber finish. This was a competition-grade tweak to which Ford's subsequent revised manufacturing processes spelled an end.

The GT's interior is completed in Dark Energy and features an F1-inspired steering wheel, fixed carbon-fiber Sparco seats, and a 6.5-inch infotainment system powered by Sync 3. Factory-installed six-point harness anchors are the sole interior option, a \$500 add-on. The car is accompanied by two keys, owner's manuals, GT battery tender, air compressor, front license plate bracket, and optional serialized Ford GT black fitted indoor car cover.

Included with the car is the Ford GT ordering kit and paint color samples of Riviera Blue, Mexico Blue, and Stealth Grey. Documentation includes the car's purchase information from Pat Milliken Ford, the car's window sticker, production photos from Multimatic Niche Vehicles (MNV), and shipment documentation proving it was delivered as a single unit direct from MNV.

With its breathtaking performance, stunning good looks, and racing pedigree, the new Ford GT is a must-have for any Blue Oval collector or supercar enthusiast.







3141

1958 Jaguar XK 150 Fixed Head Coupe

\$60,000 - \$70,000 OFFERED WITHOUT RESERVE

Powered by a DOHC inline six-cylinder engine with dual SU carburetors

Equipped with fog lights and fender mounted sideview mirrors

Interior features Smiths instrumentation and sun visors

Rides on Dunlop tires mounted on knock-off wire wheels



3142

1987 Mercedes-Benz Autosalon 2000 Super Sport

\$60,000 - \$70,000

5.6-liter V-8 engine; automatic transmission

Less than 17,000 original miles

Period upgraded 560 SEC by Autosalon 2000 of Miami, Florida

Stunning custom conversion offered in very limited numbers

Interior completed by renowned Carat by Duchatelet

Features metal widebody kit, including bumpers

Attractively finished in white over white with matching Ronal wheels

Ideal Cars and Coffee or Radwood entrant

The ultimate in '80s opulence



3143

1929 Packard Eight Roadster

\$80,000 - \$100,000

Inline eight-cylinder engine; three-speed manual transmission with overdrive

AACA National First Prize Award Winner in 2013

Recent mechanical overhaul by Dave Pruitt

Equipped with dual cowl lights, wind wings, dual side-mounted spares, rumble seat, and golf club door

Interior features a Jaeger clock and Trico driver's side wiper



3145

1962 Volvo PV544

\$12,000 - \$18,000 OFFERED WITHOUT RESERVE

60 hp, 1,583-cc inline four-cylinder engine

Three-speed manual transmission

Beautifully restored example

Wonderful two-tone interior



3146

1957 Dodge Royal Lancer Super D-500 Coupe

\$45,000 - \$55,000

- 310 hp, 325 cu. in. Hemi V-8 engine
- Powerflite push-button automatic transmission
- Equipped with power windows, steering, and brakes
- Attractive two-tone color combination



3147

1916 Ford Model T Touring

\$10,000 - \$15,000 OFFERED WITHOUT RESERVE

- 20 bhp, 176 cu. in. L-head inline four-cylinder engine
- Two-speed planetary transmission
- Nicely restored example finished in black with red pin striping
- Wonderful brass finishes
- Rides on whitewall tires mounted on wood spoke wheels



3148

1960 Ford Thunderbird Coupe

\$25,000 - \$30,000

- 300 hp, 352 cu. in. V-8; automatic transmission
- Factory example with sunroof; one of just 2,536
- Power steering, windows, and seats
- Features air conditioning, leather bucket seats, dual side view mirrors, continental kit, and center tank mounted antenna
- Fitted with Kelsey-Hayes chrome wire wheels with wide whitewall tires



3149

1958 Austin-Healey 100-6 BN4

\$35,000 - \$45,000 OFFERED WITHOUT RESERVE

- Inline six-cylinder engine with twin SU carburetors
- Manual transmission with overdrive
- Beautifully restored example
- Interior features black leather seats with red piping
- Woodgrain dashboard and steering wheel
- Accompanied by a black top, side curtains, and black tonneau cover
- Rides on Cooper tires mounted on painted knock-off wire wheels
- Spare and jack included



3150

1957 Cadillac Series 62 Hardtop Sedan

\$25,000 - \$30,000



3151

1934 Chevrolet Master Six Coupe

\$35,000 - \$40,000



3152

1957 MG MGA 1500 Roadster

\$25,000 - \$35,000 OFFERED WITHOUT RESERVE



3153

1972 Chevrolet Camaro SS Restomod

\$30,000 - \$35,000



3154

1957 Jaguar Mark I

\$35,000 - \$40,000 OFFERED WITHOUT RESERVE



3155

1949 Chrysler Town and Country Convertible

\$30,000 - \$35,000

1967 Chevrolet Corvette Sting Ray 427/435 Coupe

\$100,000 - \$130,000



3156

435 hp, 427 cu. in. V-8 engine with L88 coded aluminum heads

Four-speed manual transmission

Originally sold through John Deihl Chevrolet of Jacksonville, FL

Body-off restoration completed in 1992; prior to that in storage since 1971

Equipped with power windows and brakes

Interior features clock and AM/FM radio

Fitted with aftermarket air conditioning

Accompanied by tank sticker and restoration photos





3158

1937 Ford Pickup

\$35,000 - \$40,000 OFFERED WITHOUT RESERVE

21-stud flathead V-8 with Stromberg 97 carburetor

Three-speed manual transmission

Restored example in attractive red and black

Equipped with dual tail lights and side-mounted spare

Rides on Firestone whitewall bias ply tires



3159

1955 Chevrolet Bel Air Convertible

\$65,000 - \$75,000

265 cu. in. V-8 engine

Three-speed column-shift manual transmission

Wonderful restored example

Finished in striking Onyx Black over red

Interior features clock and radio

Coming out of twenty-five year ownership

Rides on wide whitewall tires; factory wheel covers



3160

1963 Studebaker Lark R2

\$50,000 - \$60,000

289 cu. in. V-8 engine with Paxton supercharger

Four-speed manual transmission

Fully restored example in great colors

Equipped with power steering and brakes

Interior features a radio

Believed to be one of 327 R2 Larks produced for 1963



3161

1965 Pontiac Tempest LeMans GTO Hardtop

\$55,000 - \$65,000

389 cu. in. Tri-Power V-8 engine; Hurst four-speed manual transmission

Specially built example for ad campaign to promote 1965 GTO

Frame-off restored to original specifications

Finished in special factory color Tiger Gold with black vinyl top

Equipped with Safe T-Track rear axle and Ride Handling package

Rides on Hurst wheels with bullet caps

Documented with PHS docs and window sticker

Formerly owned by Reggie Jackson



3162

1958 Buick Century Convertible

\$50,000 - \$60,000

364 cu. in. V-8 engine; automatic transmission

Purchased new for Alicia Cárdenas; daughter of the 44th President of Mexico Lázaro Cárdenas

Originally sold through a Buick dealership in Comanche, Texas and shipped to Mexico City

Consignors purchased the car in 2003 from a collector in Mexico

Restored example, excellent presentation throughout

Retains Mexican registration plate

One of 2,588 Buick Century Convertibles produced for 1958



3163

1960 Ford F-100 Pickup

\$35,000 - \$40,000 OFFERED WITHOUT RESERVE

292 cu. in. V-8 engine

Three-speed manual transmission

Features a painted wood bed and side-mounted spare

Rides on whitewall tires; factory wheel covers



3165

1980 Chevrolet Camaro Z/28

\$20,000 - \$25,000 OFFERED WITHOUT RESERVE

350 cu. in. V-8 engine featuring 10.25:1 forged pistons, small chamber heads, Lunati cam, Headman headers, and 2 1/2 inch exhaust

T-10 four-speed manual transmission

Factory T-Tops (glass); front and rear spoilers

Lowered suspension; Eibach front springs

New ball joints and tie rod ends; Urethane bushings



3166

2012 Ford Mustang Boss 302 Laguna Seca

\$35,000 - \$45,000 OFFERED WITHOUT RESERVE

444 hp, 5.0-liter V-8 engine; six-speed manual transmission

Odometer displays less than 600 miles from new

One of 767 Boss 302 Laguna Seca examples produced in 2012

Interior features Recaro seats and an alcantara-suede steering wheel

Dash-mounted Boss instrument cluster

Rear seat delete - replaced with X-brace

Includes new front splitter and hardware unopened in box



3167

1956 Chevrolet Bel Air

\$24,000 - \$28,000

V-8 engine; Powerglide automatic transmission

Described by owner as a survivor example

Equipped with power windows and brakes



3168

1949 Chrysler Town and Country Convertible

\$35,000 - \$40,000

323.5 cu. in. straight eight-cylinder engine

Three-speed manual transmission

Equipped with fog lights and dual sideview mirrors

Leather interior features clock and pushbutton radio

Wide whitewall tires with factory wheel covers

Owner believes it to be a survivor example

One of 993 Town and Country Convertibles produced for 1949



3169

1953 Chevrolet 3100 Pickup

\$30,000 - \$38,000 OFFERED WITHOUT RESERVE

'Thrift Master' straight six-cylinder engine

Manual transmission

Fully restored example; presents beautifully

Equipped with fog lights, sun visor, and dual sideview mirrors



3171

1966 Triumph TR4A

\$30,000 - \$40,000 OFFERED WITHOUT RESERVE

Inline four-cylinder engine with twin SU carburetors

Four-speed manual transmission

Stunning styling by Michelotti with a versatile hardtop

Photo-documented restoration with receipts

Shown at the 2013 Palos Verdes Concours d'Elegance

Accompanied by its British Motor Industry Heritage Trust (BMIT) Certificate

1988 Porsche 911 Turbo Cabriolet

\$90,000 - \$120,000



3173

3.3-liter turbocharged flat-six; four-speed manual transmission

Finished in attractive Venetian Blue over white leather

Equipped with air conditioning and Blaupunkt AM/FM cassette player

Fitted with matching blue soft top

Sits on polished Fuchs-style wheels

Power door locks and windows





3175

1999 Rolls-Royce Silver Seraph

\$30,000 - \$35,000 OFFERED WITHOUT RESERVE

5.4-liter V-12 engine; automatic transmission

Odometer displays less than 31,500 miles

Finished in Black with Costwold Hide with Black piping interior with Wilton carpets and lambswool rugs

Equipped with adaptive suspension, automatic ride and headlamp leveling, multi-zone climate control, electric front seats with memory, and electrically adjustable steering column

Retains factory Motorola car phone and four Rolls-Royce umbrellas

Accompanied by window sticker, manuals, tools and roadside kit

Original MSRP of \$220,365



3176

1999 Mercedes-Benz SL500

\$10,000 - \$15,000 OFFERED WITHOUT RESERVE

5.0-liter V-8 engine; automatic transmission

New black convertible top

Features AM/FM radio with CD and cassette

Numerous power amenities

Equipped with air conditioning and heated seats

Rides on 17-inch aluminum wheels

Accompanied by manuals



3178

1970 Oldsmobile 442

\$35,000 - \$45,000

V-8 engine; four-speed manual transmission with Hurst shifter

Nicely restored example; great color combination

Factory air conditioning; power steering and brakes

Interior features bucket seats, console, and AM/FM radio

Rides on Goodyear Eagle ST tires; factory wheels



3179

1957 Buick Caballero Estate Wagon with Vespa Scooter

\$70,000 - \$80,000

Rebuilt 364 cu. in. V-8 engine

Dynaflow automatic transmission

West coast car, reported to be a three-owner example from new

New two-tone exterior paint; matching interior

Interior features seatbelts, radio, clock, and split rear seat,

Aftermarket Air conditioning; power steering and brakes

Dual spotlight sideview mirrors

Accompanied by 1970 Vespa scooter with transport rack

1970 Ford Mustang Boss 302

\$65,000 - \$70,000



3180

302 cu. in. V-8 engine

Four-speed manual transmission with Hurst shifter

Traction-Lok 3.91 rear differential

Finished in attractive Grabber Blue

Features white vinyl bucket seats

Power steering and brakes

Accompanied by Marti Report



2002 Porsche 911 Turbo Coupe

\$60,000 - \$80,000



3181

415 hp twin-turbocharged flat six-cylinder engine

Desirable six-speed manual transmission

Less than 9,300 original miles; two-owner example

Finished in Arctic Silver Metallic over Black leather

Equipped with Turbo Aerokit,
sunroof, and painted calipers

Hood has been repainted

Accompanied by owner's manuals





3182

1955 Ford Fairlane Crown Victoria

\$45,000 - \$55,000

292 cu. in. V-8 engine; Ford-O-Matic transmission

Finished in Torch Red and Snowshoe White

Equipped with power steering and brakes

Exceptionally well optioned

Antique Automobile Club of America (AAACA) Senior Grand National Award winner, 2018

Wonderful example of Ford's top-of-the-line Crown Victoria



3183

1928 Ford Model A Roadster Pickup

\$20,000 - \$25,000 OFFERED WITHOUT RESERVE

40 bhp, 200 cu. in. inline four-cylinder engine

Three-speed manual transmission

Body-off restored to original specifications years ago

Finished in black with straw-colored pinstripe and painted wire wheels

Accessories include wood bed rails, single side-mounted spare, dual side mirrors, radiator stone guard, and cowlights



3184

1955 Willys 4-Wheel-Drive Station Wagon

\$18,000 - \$25,000 OFFERED WITHOUT RESERVE

Inline six-cylinder engine

Four-speed manual transmission

Four-wheel-drive transfer case

Stunning frame-off restoration, including drivetrain rebuild

Beautiful new leather interior

New wiring harness and tires



3194

1952 MG TD

\$12,000 - \$18,000 OFFERED WITHOUT RESERVE

1,250-cc four-cylinder engine

Utilizes four-speed manual transmission

Features rear luggage rack

Includes rear-mounted spare

1966 Chevrolet Chevy II Nova SS L79

\$80,000 - \$100,000

CHASSIS NO. 118376W150156



3195

Retains original L79 350 hp, 327 cu. in. V-8
Muncie four-speed transmission with Hurst shifter
Jerry MacNeish-certified original L79 car
Just 18,587 documented original miles
Original Protect-O-Plate and copy of window sticker

In 1966 the all-new Chevy IIs delivered a razor-sharp restyle based on the earlier Super Nova concept car. The proportions flowed much better than the earlier cars, while the overall dimensions were largely unchanged. The styling proved popular, and interest in the top-tier Nova Super Sport spiked. Super Sports received all-vinyl interior trim with optional bucket seats, electric clock, and SS trim.

Ultimately 20,986 Nova Super Sport two-door hardtop coupes passed through showrooms and onto American roads. Of those premium Nova SS, only 5,481 lucky owners

could lay claim to the legendary 350 hp L79 model. The secret of the L79 Nova SS was a high power-to-weight ratio. The sublime detailing of the Super Sport didn't overtly advertise its 10 pounds per horsepower potency. With all that power and the ability to quickly push near 6,000 rpm, the little Nova SS surprised owners of larger-engined competitors.

This beautiful 1966 Chevrolet Chevy II Nova SS L79 was assembled at GM's Ypsilanti, Michigan, plant and delivered to Atwood Chevrolet in Bristol, Connecticut, having been purchased new by Joseph R.C. Michaud. Finished in Marina

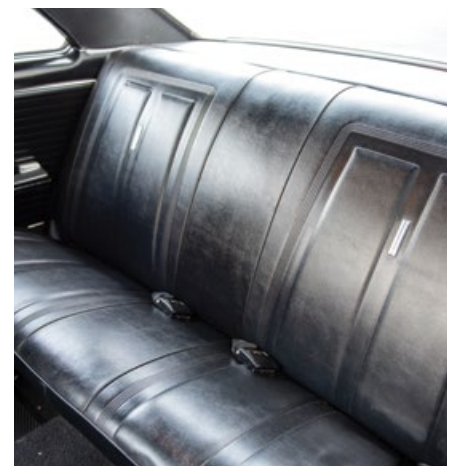

Blue over black vinyl trim, this stunning example has covered only 18,587 documented, original miles over very limited ownership. A stunning time capsule, it boasts not only its original Protect-O-Plate and copy of its window sticker, it retains its original chrome and impeccable original black interior with flawless dash, bucket seats, and Delco AM radio. It is fitted with BFGoodrich Silvertown thin whitewall tires and SS wheel covers. At one time the car resided on the West Coast, which is where it acquired its California black plate. Most significantly, this beautifully presented L79 Nova SS includes respected Chevrolet historian Jerry MacNeish's certification as an original L79 car still retaining its factory engine.



29 AUGUST-1 SEPTEMBER 2019
AUBURN AUCTION PARK

FALL

AUBURN

AUCTION • CAR CORRAL • SWAP MEET

Sunday

| 1 September 2019

| Cars 11:00 a.m.

STILL ACCEPTING CONSIGNMENTS

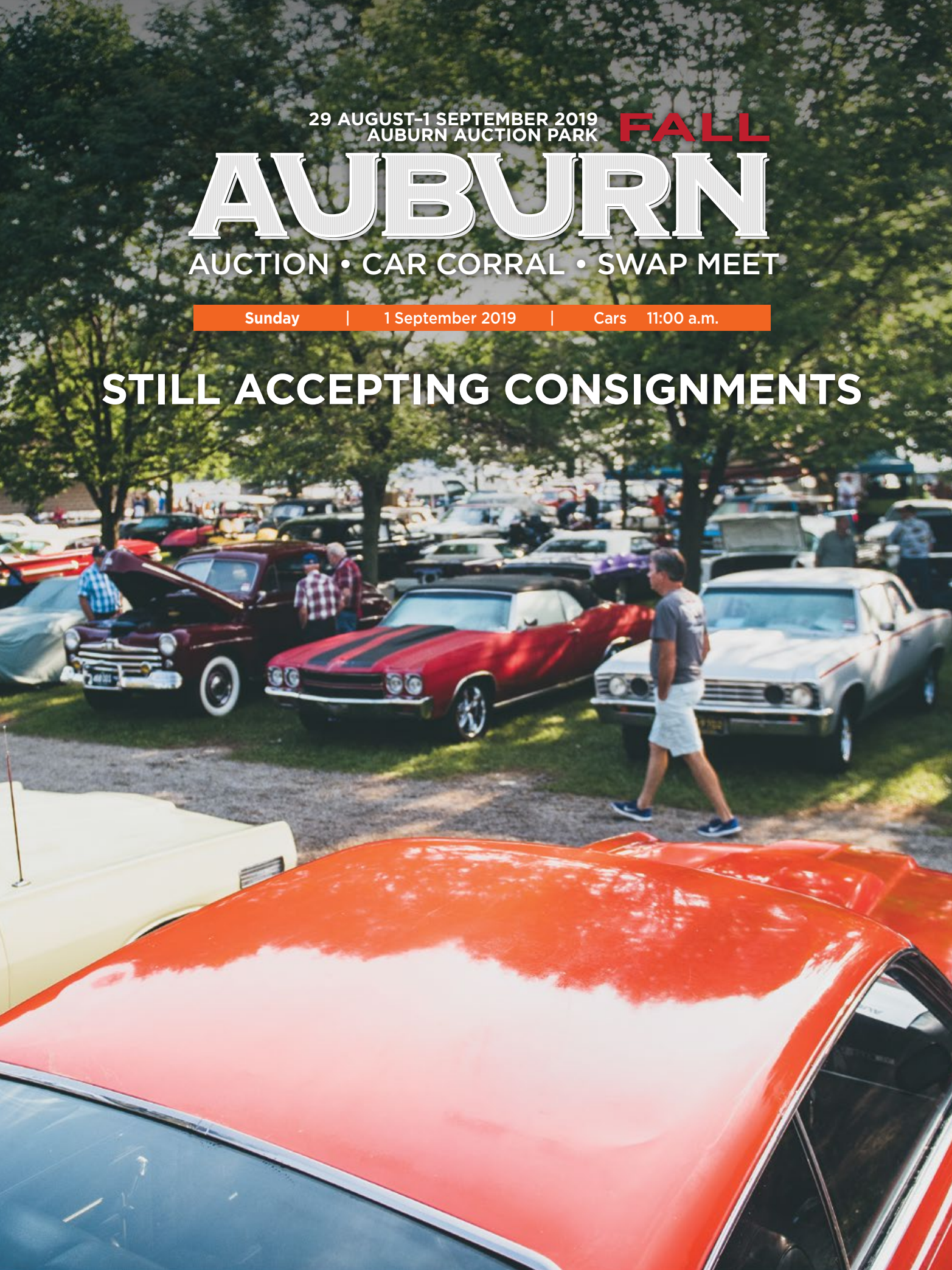



4055

1935 Chrysler C6 Four-Door Sedan

\$8,000 - \$12,000 OFFERED WITHOUT RESERVE

241 cu. in. inline six-cylinder engine; three-speed manual transmission

Believed to be a most original example

Rides on wide whitewall tires mounted on artillery-style wheels with factory hub caps

Equipped with hydraulic brakes and dual-windscreen wipers

Believed to be one of 6,055 produced

Driven and maintained by current owner



4057

1953 Chevrolet 3100 Five-Window Pickup

\$25,000 - \$30,000 OFFERED WITHOUT RESERVE

Inline-six cylinder engine featuring dual carburetors

Column-shift three-speed manual transmission

Wonderful older restoration

Features wood bed with chrome slats

Interior is completed in brown vinyl; features radio and heater

Aftermarket accessories include turn signals and gauges



4060

1973 Chevrolet Corvette Stingray Coupe

\$10,000 - \$15,000 OFFERED WITHOUT RESERVE

350 cu. in. V-8 engine; console-shift automatic transmission

Equipped with factory air conditioning; power steering and brakes

T-Tops and telescoping steering wheel

Features independent front and rear suspension; four-wheel disc brakes

Wonderful two-owner example



4065

1960 Chevrolet El Camino

\$28,000 - \$32,000

350 cu. in. V-8 engine with performance upgrades

Turbo 350 automatic transmission

Equipped with power steering and brakes (front disc)

Fitted with aftermarket air conditioning

Rides on radial tires mounted on American Racing wheels

ACKNOWLEDGMENTS

SPECIAL THANK-YOU

British Motor Industry Heritage Trust	Kevin Marti
Cadillac Historical Services	Mercedes-Benz Classic Center
Ford Show Parts	Porsche Cars North America
GM Heritage Center	SAAC Shelby Registry
Jeremy Harris	Shelby American
The Henry Ford	Jonathan Sierakowski
Jaguar Clubs of North America	Chris Summers
Jaguar Heritage Trust	

PHOTOGRAPHY

Justin Casterline	Nate Lane
Nathan Deremer	Teddy Pieper
Corey Escobar	Darin Schnabel
Karissa Hosek	Keith Tredler
Greg Keysar	Ian Wood

RESEARCH & EDITORIAL

Cary Ahl	Meagan Lobzun
Alexandra Antonel	Matt Lynch
Zach Dillinger	Eugene Robertson
Greg Duckloe	Lauren Warchol
Andrew Ganz	

CREATIVE DEPARTMENT MANAGER

Craig Plowman

CREATIVE DEPARTMENT

Adriaan Geluk
Jordan Kwasnycia
MacKenzie McEwen
Chris Montpetit
Patrick Olds
Anthony Poupard
Martin Steele
Bartlomiej Wnęk

GUIDE TO BUYING AT AUCTION

CONTRACTUAL OBLIGATIONS

Please consult the Bidders' Conditions of Business for details on your contractual obligations of bidding at this or any other RM Auctions, Inc. ("RM") auction.

POST-SALE SETTLEMENT

In the event of a successful bid, our Administration department will e-mail you a copy of your Bill of Sale and wire transfer instructions following the sale. Payment is due in full on or before 5:00 p.m. of the next business day following the auction, and payment is to be made to RM. All payments must be in the form of cash or certified funds unless other arrangements have been approved in advance. Cash payments will be reported according to U.S. federal government requirements.

ADDITIONAL FEES AND TAXES

The final bid price does not include the Buyers' Premium or applicable taxes on each lot purchased. The Buyer is responsible to pay all city, state, federal, provincial, territorial, and any and all other taxes due for which the Buyer does not qualify as exempt, subject to RMS certification; proof of exemption is the Buyer's responsibility. The Buyer is responsible for any applicable duty, import tariffs, charges, or any and all other required payments that are due upon the import of the lot to its final destination.

BUYERS' PREMIUM

In addition to the Hammer Price, the winning Bidder is required to pay RM a percentage of the Hammer Price, which RM retains as the Buyers' Premium for their purchase of each motor car or any other lot ("Buyers' Premium") in accordance with the following clauses:

- RM will receive a Buyers' Premium of ten percent (10%) on all motor car lots.
- Buyers of all non-motor-car lots, including but not limited to memorabilia, motorcycles, boats, trailers, jewelry, and clothing, are required to pay RM a Buyers' Premium of fifteen percent (15%) on the Hammer Price of that particular lot.

TITLE TRANSFER

In an effort to ensure all titles are free and clear of liens or encumbrances, RM manages the process of title reassignment on your behalf. Buyers will receive titles via UPS up to twenty (20) business days following the auction.

ADMINISTRATION CONTACT INFORMATION

TANYA PAWLAK

t: +1 519 352 4575
m: +1 519 365 7011
tpawlak@rmsothebys.com

OLIVIA WALKER

t: +1 519 352 4575
m: +1 519 359 8513
owalker@rmsothebys.com

KATE CLENNING

t: +1 519 437 3064
m: +1 260 226 9497
kclenning@rmsothebys.com

BIDDING INCREMENTS

Under normal circumstances, the auction estimate of the lots being auctioned off will determine the minimum increment the auctioneer will accept. Please note that due to the nature of a live auction, it is at the auctioneer's sole discretion to accept bids outside of what is being asked for during the live auction.

REMOVAL OF PURCHASED LOTS

All purchased lots must be removed from the auction site by the next business day by 3:00 p.m. EST ("Removal Deadline"). If the lot is not removed by the Removal Deadline, the Buyer will be charged a daily storage fee of up to \$30.00 (US) until the lot is removed. Please note that the Buyer is required to insure their lot while it is being stored on their behalf.

DOMESTIC SHIPPING

Representatives from Reliable Carriers, RM's official carrier sponsor, will be on-site to assist clients wishing to transport any motor cars purchased at auction. For further information on transporting your purchased lots, please contact:



Reliable Carriers, Inc.
800 521 6393
www.reliablecarriers.com

INTERNATIONAL SHIPPING

Please contact Mike Brablec at the number provided below for recommendations and assistance.

TRANSPORTATION CONTACT INFORMATION

MIKE BRABLEC

+1 519 436 8765
mbrablec@rmsothebys.com

DONNA TOMLINSON

+1 519 352 4575
dtomlinson@rmsothebys.com

INSURANCE

RM's official insurance partner is Hagerty, the global leader in classic car insurance. Hagerty representatives will be available on-site for assistance. For more information, please contact:



Hagerty
+1 800 922 4050
www.hagerty.com



THERE'S NOT AN APP FOR THIS



HAGERTY
FOR PEOPLE WHO LOVE CARS

INSURANCE. DRIVERS CLUB. CAR VALUES. ENTERTAINMENT. THE SHOP. DRIVESHARE.

Drive with us. Exclusive collector vehicle insurance sponsor for RM Sotheby's.



800.922.4050 | HAGERTY.COM



877.922.9701 | HAGERTY.CA



0333 323 0989 | HAGERTYINSURANCE.CO.UK

Vehicle make and model names and logos are property of their respective owners and their inclusion does not imply sponsorship of or affiliation with Hagerty or any of its products or services. Hagerty Insurance Agency, LLC, (HIA) determines final risk acceptance. Purchase of insurance through HIA is not required to receive optional products or services through Hagerty Drivers Club, The Shop, or DriveShare. Hagerty, the Steering Wheel logo, HAGERTY FOR PEOPLE WHO LOVE CARS, THE SHOP ASSEMBLED BY HAGERTY, and DRIVESHARE BY HAGERTY are registered or common law trademarks of The Hagerty Group, LLC. ©2019

CONSIGNORS' CONDITIONS OF BUSINESS

1. Introduction:

- 1.1 Please ensure that you read and understand these Conditions of Business ("Conditions") prior to consigning a Motor Car or Any Other Lot at this or any other RM Auctions, Inc. ("RM") sale.
- 1.2 RM's contractual relationship with the Consignors is governed by:
 - 1.2.1 These Consignors' Conditions of Business;
 - 1.2.2 The Consignment Agreement package; for the avoidance of doubt, this is the fillable package containing the Consignor's personal information and information regarding the Motor Car or Any Other Lot;
 - 1.2.3 The Conditions of Business displayed in the auction salesroom;
 - 1.2.4 The Conditions of Business displayed on RM's website; and
 - 1.2.5 In each case as amended by any salesroom notice or auctioneer's announcement at the auction.

(clauses 1.2 to 1.2.5 together "Contractual Obligations".)

- 1.3 As auctioneer, RM acts as agent for the Consignor, and a sales contract is made directly between the Consignor and the Buyer.

- 1.3.1 Occasionally, RM may own a Motor Car or Any Other Lot (and in such circumstances, acts in a principal capacity as the Seller) and/or may have a legal, beneficial, or financial interest in a Motor Car or Any Other Lot as a secured creditor or otherwise.

2. **RM Receiving Motor Car or Any Other Lot in Trust:** Any consigned Motor Car or Any Other Lot is delivered to RM in trust under the exact terms set forth in these Conditions. RM agrees to receive the Motor Car or Any Other Lot in trust and not to permit its use for any other purposes, other than those contained in these Conditions, without the express written consent of the Consignor.

3. **Services:** RM agrees to act as an agent for the Consignor and provide auction services, including, but not limited to, a sales facility, clerks, support staff, event advertising, and promotion. In connection with the auction, RM will have absolute discretion with regard to the Motor Car or Any Other Lot or any RM auction as to (a) consulting any expert either before or after the sale, (b) researching the provenance, (c) grouping and providing catalogue and other descriptions as may be appropriate, (d) marketing and promotion of the sale, and (e) any other services required to conduct the sale.

4. **Commissions.** If the Motor Car or Any Other Lot is sold, the Consignor agrees to pay the Sellers' Commission on the Hammer Price (the last accepted bid is the Hammer Price ("Hammer Price")) of the Motor Car or Any Other Lot to RM, as indicated in the Commissions section of the consignment package. Further, the Consignor acknowledges that RM will collect a Buyers' Premium from the Buyer of the Motor Car or Any Other Lot in question, based on the Hammer Price on the Motor Car or Any Other Lot. Please note that the Buyers' Premium may be subject to change at the discretion of RM if the standard Buyers' Premium for the auction changes. To be clear, the Buyers' Premium on the Motor Car or Any Other Lot

will not be different from the Buyers' Premium for other motor car lots or any other lots in the auction.

5. Proceeds to Consignor:

- 5.1 As an accommodation to the Consignor, RM agrees to act as an intermediary between the Consignor and the Buyer by accepting the purchase price from the Buyer, transferring the Motor Car or Any Other Lot to the Buyer, and delivering the amounts due to the Consignor under these Conditions. If the Motor Car or Any Other Lot is sold by RM during the term of these Conditions, the money due to the Consignor shall be disbursed within 20 business days after the sale, provided that the purchase price, applicable commissions, and fees have been received by RM, in accordance with the terms of these Conditions.

- 5.2 As used in these Conditions, a "sale" occurs between the Consignor and the Buyer when the hammer or equivalent device or mechanism drops on the Hammer Price or when the auctioneer awards the Motor Car or Any Other Lot to the highest Bidder.

- 5.3 The Consignor authorizes RM to release the Motor Car or Any Other Lot to the successful Buyer upon RM receiving full payment from the Buyer or financing terms as agreed to with RM.

- 5.4 The Consignor agrees to rely solely upon the Buyer for payment.

- 5.5 Before payment of any money due to the Consignor is to be made, the Consignor agrees to provide RM with the documents necessary to transfer the ownership of the Motor Car or Any Other Lot to the Buyer.

- 5.6 If RM has reason to believe or is notified that the (i) Consignor's breach of the Contractual Obligations, (ii) alleged breach of the Contractual Obligations, (iii) Consignor's actions could potentially cause RM liability, and/or (iv) Buyer claims material misrepresentation within the Twenty Day Window (defined below) as outlined in clause 10 ("dispute"), RM, at its sole discretion, may withhold payment to the Consignor until the dispute has been resolved; further, RM may deduct any sums that are due to it from the sum held.

6. **Exclusivity:** The Consignor grants to RM the exclusive right and authority to advertise and sell the Motor Car or Any Other Lot for a period beginning with the date of these Conditions and ending 60 business days following the auction.

- 6.1 If the Motor Car or Any Other Lot is sold prior to the auction and RM has not agreed in writing to this sale, the Motor Car or Any Other Lot will then be considered "withdrawn" from the auction by the Consignor, and the Consignor agrees to abide by clause 20, Withdrawn Motor Car or Any Other Lot, of these Conditions.

- 6.2 If the Motor Car or Any Other Lot does not sell at auction, the Consignor grants RM the authority to list the Motor Car or Any Other Lot for sale on RM's Private Sales website and advertise, in other media at RM's discretion, the Motor Car or Any Other Lot for sale up to 60 days after the auction.

- 6.2.1 RM does not have the authority to unilaterally sell the Consignor's Motor Car or Any Other Lot after the auction and must submit what RM believes to be commercially reasonable offers for sale to the Consignor.

- 6.2.2 If the Consignor agrees to the sale of the Motor Car or Any Other Lot, the Consignor will be required to pay RM a percentage of the sale price as an administrative fee, based on RM's standard payment grid.

7. Title, Registration Documents, and/or Appropriate Documents Evidencing Chain of Ownership to the Motor Car or Any Other Lot:

- 7.1 It is the absolute requirement of the Consignor that they provide any and all titles, registration documents, or appropriate documents evidencing ownership and/or government registrations (such as Purchase Agreements and Bills of Sale) ("Titles") to the Motor Car or Any Other Lot to RM prior to the auction of the Motor Car or Any Other Lot.

- 7.2 The Consignor warrants that the Consignor is the sole owner of the Motor Car or Any Other Lot, and that the Consignor has full right and authority to sell the Motor Car or Any Other Lot.

- 7.3 The Consignor agrees to provide RM with a good, clear, and transferable Title to the Motor Car or Any Other Lot in advance of the auction.

- 7.3.1 If for whatever reason RM is forced to correct any Title defect, the Consignor agrees to first pay RM a minimum fee of US\$500 and, if the Title defect costs more than US\$500 to correct, the Consignor agrees to pay for any and all additional reasonable expenses related to correcting such defect ("Title Fees"). The Title Fees will be deducted from the Consignor's proceeds of sale.

- 7.3.1.1 In cases where pre-existing Titles do not exist and insurance bonds are necessary, the Consignor will be charged Title Fees on a case-by-case basis.

- 7.4 In order to facilitate and transfer the Title for the Motor Car or Any Other Lot, the Consignor agrees to sign a Power of Attorney attached in the Consignment Agreement package.

8. **Non-Payment by Buyer:** In the event of non-payment by the Buyer, RM will endeavor to use reasonable efforts to enforce payment from the Buyer; however, RM shall not be liable to the Consignor for payment. If the Buyer does not pay RM, then at RM's sole discretion, RM may cancel the sale and return the Motor Car or Any Other Lot to the Consignor, enforce payment by the Buyer, or take other actions permitted by law. Notwithstanding the preceding sentences, if RM has paid any portion of the purchase price to the Consignor, but the purchase price has not been collected from the Buyer of the Motor Car or Any Other Lot, the Consignor hereby agrees, simultaneously with such payment, to assign to RM any and all rights that the Consignor may have against such Buyers to the extent of such payment, whether at law, in equity, or under the Contractual Obligations. The Consignor agrees to execute any documents reasonably necessary to evidence this assignment, including with respect to the Consignor's representations, warranties, and indemnities set forth in these Conditions. The Consignor authorizes RM, at RM's sole discretion, to impose on any Buyer, and retain for RM's account, a late charge if payment is not made in accordance with the Contractual Obligations.



WHEREVER YOU ARE, **THERE WE GO**

When it comes to your collector vehicle, you want a company who can securely transport your ride. As North America's largest specialized automotive transporter, you can count on Reliable to move your classic car in climate-controlled conditions or deliver your newest auction purchase right to your front door. Plus, \$5 million worth of insurance is standard on every load. **That's capability. That's flexibility. That's Reliability.**



800.521.6393

reliablecarriers.com

EXCLUSIVE CARRIER OF



Sotheby's

CONSIGNORS' CONDITIONS OF BUSINESS

9. Motor Car or Any Other Lot Description:

- 9.1 The Consignor agrees to accept sole responsibility and liability for any representations made by RM that accurately repeat the information supplied by the Consignor as to the character, features, condition, correctness, authenticity, or history of the Motor Car or Any Other Lot and to indemnify, defend, and hold RM harmless from any claims that may be made with respect to any such representations.
- 9.2 The Consignor is required to review and approve any and all catalogue descriptions within 2 business days of receiving the catalogue descriptions from RM's Research department; if RM does not receive a response to its request to review within 2 business days, RM will consider this an approval of the catalogue description and a representation that RM can rely upon.

10. Twenty Day Window for Rescission of Sale due to Material Misrepresentation Claims:

- 10.1. RM will review concerns regarding material misrepresentations raised by the Buyer for 20 business days from the date of the auction.
- 10.2. If it is found that the alleged material misrepresentation (that would not have been reasonably found through the Bidder's due diligence) materially decreases the value or functionality of the Motor Car or Any Other Lot, RM will work with the Buyer to reach a solution.
- 10.2.1. The Consignor agrees to indemnify, defend, and hold RM harmless from any claims that may be made with respect to any Buyer alleged damages or liability, including but not limited to, travel expenses, repair expenses, and inspection expenses in any way related to actions taken in accordance with clause 10.

(clause 10 to 10.2.1 together "Twenty Day Window")

11. Motor Car or Any Other Lot Operation:

- 11.1 The Consignor warrants that the Motor Car or Any Other Lot is in a safe, operable condition to be driven or moved by RM's employees or representatives. The Consignor acknowledges that, should RM, at RM's sole discretion, determine that the Motor Car or Any Other Lot is not safe to operate or move, the Motor Car or Any Other Lot will not be allowed across the block.
- 11.2 The Consignor authorizes RM to perform minor work on the Motor Car or Any Other Lot to facilitate the Motor Car or Any Other Lot starting and driving across the auction block or being presentable for sale. The Consignor will hold RM harmless and indemnify RM from any damage or liability caused by the minor work performed by RM's staff on the Motor Car or Any Other Lot.
12. **Drivers:** The Consignor acknowledges and grants permission for RM and its employees and agents to drive or move the Motor Car or Any Other Lot from time to time before, during, or after the sale. The Consignor acknowledges that it is the Consignor's responsibility to maintain sufficient insurance coverage to permit such driving or moving, and the Consignor specifically agrees to indemnify, defend, and hold RM harmless, as provided in these Conditions, from any liability that may result from such driving or movement of the Motor Car or Any Other Lot.

13. No-Sale of Motor Car or Any Other Lot:

- 13.1 If there is a no-sale, any and all fees owing, including but not limited to Title Fees, must be paid to RM before the Motor Car or Any Other Lot is released to the Consignor.
- 13.2 At the termination of these Conditions due to a no-sale, the Consignor is required to remove their non-sold motor cars, including motorcycles, boats, and trailers, from the auction site by 3:00 p.m. of the next business day in the jurisdiction where the auction was held ("**Removal Deadline**").
- 13.3 Contingent upon clause 13.2 being satisfied, the Motor Car's Title (as long as the Consignor does not owe RM any money) will be returned to the Consignor within sixty (60) business days.
- 13.4 If any Motor Car, including motorcycles, boats, and trailers, are not removed by the Removal Deadline (or are not granted authority to be removed due to clause 13.1), RM will remove the Motor Car, including motorcycles, boats, and trailers, and the Consignor is required to pay RM a daily storage fee of US\$30.
- 13.5 For the removal of a non-motor car lot, including but not limited to memorabilia, jewelry, and clothing, from the auction site, a direct shipping company will contact the Consignor after the sale; please note that a reasonable memorabilia removal and storage fee will apply.
- 13.6 If the Consignor has not removed their Motor Car or Any Other Lot from the storage facility within 6 months of the sale date, RM has the right to enter the Motor Car or Any Other Lot into an auction at no reserve or to sell it via private treaty for fair market value.
- 13.6.1 Once sold, RM will retain all reasonable expenses, auction fees if sold via auction, and if sold via private treaty, a 20% commission; if there are any remaining funds, these will be returned to the Consignor within 30 business days of the sale.

- 13.7 RM shall have the right to exercise a charge or lien on the non-sold Motor Car or Any Other Lot, or any other property belonging to the Consignor in the possession of RM if the Consignor owes RM money, and to apply any money due or to become due to the Consignor to the outstanding money the Consignor owes to RM.

14. **Cancellation/Rescission of Auction:** RM will use reasonable efforts to avoid cancellation/rescission; however, RM has the sole discretion to cancel/rescind the auction and will not be liable to the Consignor for any losses or damages resulting from the cancellation/rescission if RM believes the following events have occurred or have a reasonable probability of occurring:

- 14.1 Force majeure events, including but not limited to:
- 14.1.1 Any natural disaster that, despite reasonable efforts, restricts RM from holding the auction;
- 14.1.2 Structural damage to the auction venue prior to the auction that, despite reasonable efforts, restricts RM from holding the auction; and
- 14.1.3 A terrorist event that, despite reasonable efforts, restricts RM from holding the auction.
- 14.2 Government/court actions, orders, injunctions, regulations, laws, or non-compliance with applicable rules, regulations, or laws to hold an auction that necessitate a cancellation.

15. Cancellation/Rescission of Motor Car or Any Other Lot:

- RM will use reasonable efforts to avoid cancellation/rescission; however, RM has the sole discretion to cancel/rescind the sale of a Motor Car or Any Other Lot and will not be liable to the Consignor for any losses or damages resulting from the cancellation/rescission if RM believes the following events have occurred or have a reasonable probability of occurring:
- 15.1 RM opines that the Motor Car or Any Other Lot has been intentionally and materially misrepresented by the Consignor;
- 15.2 RM opines that physical damage to the Motor Car or Any Other Lot, which cannot be sufficiently repaired prior to the auction, occurred after these Conditions were signed;
- 15.3 RM is served with a lawsuit from a third party in relation to the Motor Car or Any Other Lot;
- 15.4 RM faces significant reputational damages that would cause monetary damages for selling the Motor Car or Any Other Lot;
- 15.5 Material issues regarding the Title, registration, or transfer of ownership that cannot be reasonably cured;
- 15.6 Material issues regarding the provenance, merchantability, or authenticity of the Motor Car or Any Other Lot that cannot be reasonably cured;
- 15.7 Government/court actions, orders, injunctions, regulations, laws, or non-compliance with applicable rules, regulations, or laws to sell the Motor Car or Any Other Lot at auction that necessitate a cancellation; or
- 15.8 If there are legitimate claims, accusations, notices, or similar communications made by the Buyer in regard to their purchase of a Motor Car or Any Other Lot not being authentic, being misrepresented, having an encumbered title or registration, having undisclosed material issues, or having a similar claim, RM has the right to retain the Buyer's funds on account and be the arbitrator as to the merit of the Buyer's claims and to cancel the sale of the Motor Car or Any Other Lot and reimburse the payment to the Buyer if RM deems the Buyer's claims to be valid.

16. **Estimates and Catalogue Descriptions:** Any pre-sale estimates are intended as guides for prospective Bidders. RM makes no representation or warranty of the anticipated selling price of a Motor Car or Any Other Lot, and no estimate anywhere by RM of the selling price of a Motor Car or Any Other Lot may be relied upon as a prediction of the actual selling price. Estimates included in catalogues, online, in pre-mailers, in any advertisements, or elsewhere are preliminary only, and they are subject to revision by RM from time to time at its sole discretion. The Consignor acknowledges that RM will not be liable for any errors or omissions in the catalogue or other descriptions of a Motor Car or Any Other Lot, and these descriptions make no guarantees, representations, or warranties whatsoever to the Consignor with respect to a Motor Car or Any Other Lot, its attribution, legal title, condition, value, or other characteristics.

17. **Odometer Statement:** The Consignor will provide a duly executed odometer statement on or before the first day of the auction, and further accepts sole responsibility for the accuracy or inaccuracy of such statement.

A REPUTATION FOR PERFECTION

Over the past 30 years, RM Auto Restoration has steadily grown and evolved into a widely recognized world-class restoration facility that has achieved unprecedented honors in the automotive restoration industry.

Whether it's a complete body-off restoration, a partial restoration, or a cosmetic upgrade, our dedicated team of restoration perfectionists provides an unwavering commitment to delivering flawless work no matter the project.



1927 Isotta Fraschini Tipo 8A S Roadster
Coachwork by Fleetwood
Chassis no. 1175

In 2000, RM Auto Restoration took to restoring every nut and bolt to authentic and original condition, finally completing the project in 2003, with multiple national awards to follow.



Restoration

RMAUTORESTORATION.COM

Ernie Morreau

t: +1 519 352 4575
m: +1 519 350 0280

emorreau@rmautorestation.com

Don McLellan

t: +1 519 352 4575
m: +1 519 350 0888

dmclellan@rmautorestation.com

UPHOLSTERY
MECHANICS
PARTS
PAINT
DETAILING

FABRICATION
TESTING
WOODWORKING
TRIM
TRANSPORT

CONSIGNORS' CONDITIONS OF BUSINESS**18. Reserve:**

18.1 A reserve price noted in the fillable section of the Auction Consignment Agreement is the lowest bid acceptable to the Consignor. Reserve prices may be lowered at any time by the Consignor, either verbally or in writing, but they may not be raised. The reserve does not include commissions to RM. RM has the right to sell the Motor Car or Any Other Lot at a price below the agreed verbal or written reserve, provided that the Consignor receives the same net proceeds as the Consignor would have received had the Reserve been met. If no reserve, indicate clearly by writing "NONE" in the space provided in the fillable section of the Auction Consignment Agreement.

18.2 If RM contributes to the Hammer Price to meet a reserve, the reserve for the respective Motor Car or Any Other Lot becomes the Hammer Price plus RM's contribution for purposes of commissions.

19. Insurance: The Consignor will be responsible for maintaining adequate property insurance on the Motor Car or Any Other Lot at all times, and this insurance must be at least equal to the aggregate low pre-sale auction estimate for the Motor Car or Any Other Lot, which in each case shall include insurance for damages to the Motor Car or Any Other Lot and shall not be cancellable by the insurance company until after ownership and Title have passed to the Buyer and the Buyer has taken possession of the Motor Car or Any Other Lot from RM. The Consignor agrees that RM and its respective affiliates and agents will not be responsible for, and the Consignor releases RM and its respective affiliates, agents, and warehouses from, any and all liability for loss of, theft of, or damage to the Motor Car or Any Other Lot.

20. Withdrawn Motor Car or Any Other Lot:

20.1 The Consignor acknowledges that RM has incurred and will incur significant costs preparing, advertising, marketing, and promoting the Motor Car or Any Other Lot for the auction.

20.2 If the Consignor withdraws one or more of the motor cars or any other lot from the auction after the signing of these Conditions, the Consignor will pay RM the Buyers' Premium and Sellers' Commission that would have been due under these Conditions, had the Motor Car or Any Other Lot (a) met their reserve; (b) if offered without reserve, then the Motor Car or Any Other Lot's published low estimate; or (c) if no published low estimate, then the Motor Car or Any Other Lot's fair market value as determined by RM, by 5:00 p.m. of the next business day following the auction.

21. Legal Action: If either party brings action against the other arising from or relating to the provisions of these Conditions, the prevailing party, as determined by the court, shall be entitled to recover its reasonable attorney fees and costs. The law of the jurisdiction in which the auction is held shall govern the provisions of these Conditions.

22. Marketing Fee: The marketing fee is non-refundable and is not credited toward the sales commission.

23. Bidding Restrictions: The Consignor hereby agrees not to bid on his/her/their Motor Car or Any Other Lot. Although the auctioneer shall be entitled to bid on the Consignor's behalf up to the amount of the reserve (if applicable), the Consignor shall neither instruct nor permit any other person to bid on behalf of the Consignor for his/her/their Motor Car or Any Other Lot. If, however, in violation of the foregoing, the Consignor (or his or her agent) bids on his/her/their Motor Car or Any Other Lot and becomes the successful Bidder, the expenses, marketing fee, repair expenses, Buyers' Premium, and Sellers' Commission on the Hammer Price shall be payable by the Consignor. If the Consignor does not pay in accordance with this clause, his/her/their Motor Car or Any Other Lot may be sold without reserve.

24. Motor Car or Any Other Lot's Batteries: If a Motor Car or Any Other Lot arrives at the auction with a dead battery, or shows signs of a draining battery, an automatic US\$200 (or the local currency equivalent) replacement fee will be charged to the Consignor.

25. Antifreeze Is the Responsibility of the Consignor:

25.1 As the Consignor's Motor Car or Any Other Lot could be shipped to a location where below-freezing temperatures are a possibility, it is the Consignor's responsibility to ensure that, within the last 6 months, they have winterized their Motor Car or Any Other Lot for shipping in freezing temperatures. Winterizing one or more of the Motor Cars or Any Other Lots means that the Consignor has completely filled and properly mixed, at a minimum, -20°F-rated antifreeze into their Motor Car or Any Other Lot's radiator.

25.2 If any damage occurs because the Consignor did not properly winterize their Motor Car or Any Other Lot, it will be the Consignor's responsibility to cover the damages, and RM may recoup these damages from the Consignor's settlement. If it is found that the Consignor did not properly winterize their Motor Car or Any Other Lot, the associated costs with checking, filling, and disposing of the antifreeze will be recapped from the Consignor's settlement; if the Motor Car or Any Other Lot is not sold, the Consignor must pay RM before the Consignor can retake possession of their Motor Car or Any Other Lot. If already settled, the Consignor must pay RM directly.

26. Entire Agreement: This document shall be binding upon the parties and their respective heirs, personal representatives, and assigns. Except as otherwise expressly provided herein, these Conditions shall not be modified, except in writing. Whenever used in these Conditions, as the contract requires, the singular number shall include the plural, the plural number shall include the singular, the masculine gender shall include the feminine and neuter, the

feminine gender shall include the masculine and neuter, and the neuter gender shall include the masculine and feminine.

27. No Legal or Tax Advice: These Conditions are an important legal document. The Consignor acknowledges that the Consignor has had the opportunity to consult an attorney before signing these Conditions and has signed these Conditions after having the opportunity to consult with an attorney of their own choosing. Notwithstanding any references to any transactions or arrangements in these Conditions, or any contemporaneous written, oral, or implied understandings of the Parties relating to the subject matter of these Conditions, RM has not provided legal or tax advice or tax planning services to the Consignor or for the Consignor's benefit in connection with the transactions contemplated by these Conditions, and no one at RM has acted as the Consignor's attorney or tax advisor.

28. Data Use: The Consignor agrees to allow RM to use their personal information in accordance with RM's privacy policy. RM uses your personal information to provide services specifically tailored toward your requirements and to treat you in a personal way; to fulfill your agreements regarding the consignment and purchases of items at RM auctions and private sales; to provide you with information on upcoming sales; to carry out analysis and market research; to undertake targeted online advertising; to send status updates and service communications; to improve our websites, products, and services; to provide payment services; and for management and administrative purposes. The full Privacy Policy can be found at the bottom of RM's website homepage under the Privacy and Terms tab. If you wish to ask any questions regarding the use of your personal information, request a full accounting of what personal information is on file with RM, unsubscribe to any services, or purge your personal information from RM's systems, please email privacy@rmsothebys.com.

29. Anti-Money Laundering: The Consignor agrees to provide all information and assistance reasonably requested by RM to comply with RM's internal anti-money laundering process and to comply with any and all anti-money laundering laws and regulations in force in the jurisdiction in which the auction is held.

30. Photography, Videography, and Illustrations: All photographs, videography, and illustrations commissioned by RM for the Motor Car or Any Other Lot are the absolute property of RM, and RM shall have the absolute right to use the photographs, videography, and illustrations as RM deems fit.



Sotheby's

REGISTER TO BID



2010 Porsche 911 GT3 RS
Chassis no. WPOZZ99ZBS780073

1992 Porsche 911 Carrera RS
Chassis no. WPOZZ96ZNS490994

1973 Porsche 911 Carrera RS 2.7 Touring
Chassis no. 9113601463

21 SEPTEMBER

THE SÁRAGGA COLLECTION

OFFERED ENTIRELY WITHOUT RESERVE

COMPORTA, PORTUGAL

HEADQUARTERS +1 519 352 4575

UK +44 (0) 20 7851 7070

NEW YORK +1 212 894 1562

CALIFORNIA +1 310 559 4575

rmsothebys.com
Collectors gather here.

BIDDERS' CONDITIONS OF BUSINESS

1. Introduction.

1.1. Please ensure that you read and understand these Conditions of Business prior to bidding on a motor car or any other lot at this or any other RM Auctions, Inc. ("RMA") or RM Sotheby's ("RMS") auction (RMA and RMS together "RM"). Even though the RM Bidders' Conditions of Business are standardized, there are unique jurisdictional requirements and terms that may not apply to every auction, and it is each Bidder's responsibility to understand and review these Conditions of Business as they apply. By agreeing to these Conditions of Business, you are agreeing to be bound by these Conditions of Business for both RMS and RMA auctions. Please note that the Bidders' Conditions of Business are subject to change, and it is each Bidder's responsibility to apprise themselves of any changes to the Bidders' Conditions of Business. Bidders are encouraged to contact RM's Client Service department at clientservices@rmsothebys.com with any questions or concerns regarding these Bidders' Conditions of Business.

1.2. RM's contractual relationship with the Bidders is governed by:

1.2.1. These Bidders' Conditions of Business;

1.2.2. The Bidders' Conditions of Business displayed in the auction salesroom;

1.2.3. The Bidders' Conditions of Business displayed on RM's website; and

1.2.4. In each case as amended by any salesroom notice, auctioneer's announcement at the auction, or website update.

(Clauses 1.2 to 1.2.4 together "Contractual Obligations".)

1.3. As auctioneer, RM acts as the agent for the Consignor, and a sale contract is made directly between the Consignor and the Buyer.

1.3.1. Occasionally, RM may own a motor car or any other lot (and, in such circumstances, acts in a principal capacity as the Seller) and/or may have a legal, beneficial, or financial interest in a motor car or any other lot as a secured creditor or otherwise.

2. Bidder Due Diligence Responsibilities. The Bidder is responsible for any and all due diligence including but not limited to inspections and verification of the (i) condition, (ii) authenticity, (iii) completeness, (iv) statements made in reference to, and (v) any and all other matters regarding any motor car or any other lot offered in an RM sale ("Bidder Due Diligence").

3. Twenty Day Window for Rescission of Sale due to Material Misrepresentation.

3.1. RM will review concerns regarding material misrepresentations raised by the Buyer for 20 business days from the date of the auction; after which time, all sales are considered "As Is" and "Where Is" as outlined in clause 4 below. Please send all concerns to legal@rmsothebys.com.

3.2. If it is found that the alleged material misrepresentation (that would not have been reasonably found through the Bidder Due Diligence) materially decreases the value or functionality of the motor car or any other lot, RM will work with the Buyer to reach a solution.

3.2.1. The Buyer agrees to indemnify, defend, and hold RM harmless from any claims that may be made with respect to any Buyer alleged damages or liability, including but not limited to, travel expenses, repair expenses, and inspection expenses in any way related to actions taken in accordance with clause 3.

(clause 3 to 3.2.1 together "Twenty Day Window")

4. With the Exception of the Twenty Day Window, All Sales Are "As Is" and "Where Is." No warranties or representations of any type whatsoever are made by RM regarding any motor car or any other lot offered in an RM sale. Statements printed in catalogues, online content, pre-mailers, advertisements, brochures, signs, and window cards, as well as verbal statements made by auctioneers or auction staff, are based on statements and historical files, if any, collected from the Consignor and other third party sources, and RM has no obligation to verify or authenticate any such statements. All motor cars or any other lots are sold as is, where is, with no representations or warranties, expressed or implied. THE CONSIGNORS AND RM DISCLAIM ALL WARRANTIES, EXPRESSED OR IMPLIED, AS TO CONDITION, ORIGINALITY, OR AUTHENTICITY; ORIGIN OR PROVENANCE; PREVIOUS USE OR OWNERSHIP; MANUFACTURING OR RESTORATION PROCESSES; YEAR OR AGE; SERIAL NUMBER, MAKE, OR MODEL; OPTIONS AND TOOLS; ENGINE HOURS; AND MILEAGE OF ANY MOTOR CAR OR ANY OTHER LOT OR COMPONENT OF ANY MOTOR CAR OR ANY OTHER LOT, AND THEY SPECIFICALLY DISCLAIM ANY WARRANTIES OF MERCHANTABILITY OR FITNESS FOR ANY PARTICULAR PURPOSE.

5. Services. RM agrees to act as an agent for the Bidders and provide auction services including, but not limited to, a sale facility, clerks, support staff, event advertising, and promotion. In connection with the auction, RM will have absolute discretion with regard to the motor car and any other lot or any RM auction as to (a) consulting any expert either before or after the sale, (b) researching provenance, (c) grouping and providing catalogue and other descriptions as may be appropriate, (d) marketing and promotion of the sale, and (e) any other services required to conduct the sale.

6. Registration Fee.

6.1. In order to register to bid onsite at auction, Bidders must pay a bidder registration fee as outlined below:

6.1.1. Up to a US\$300 bidder registration fee for RMS North American auctions;

6.1.2. Up to a US\$400 bidder registration fee for RMA North American auctions;

6.1.3. A €200 bidder registration fee for RMS Paris auctions;

6.1.4. A €200 bidder registration fee for RMS Monaco and Villa Erba auctions; and

6.1.5. A £150 bidder registration fee for RMS London, United Kingdom, auctions.

6.2. Please note that the registration fees outlined in the clauses above are subject to change by any salesroom notice, auctioneer's announcement at the auction, catalogue update, or website update, and it is each Bidder's responsibility to apprise themselves of any changes to the registration fees.

7. Bidding.

7.1. To bid at an RM auction, a Bidder must be at least 21 years of age.

7.2. At auction, there is no "cooling-off period." If you are awarded the final bid, ownership changes hands at the drop of the gavel. You own the motor car or any other lot and are responsible for payment in full. No Bidder may retract a bid made during the sale for any reason.

7.3. The Bidder is responsible for all risk of loss or damage and insurance immediately upon purchase of the motor car or any other lot.

7.4. RM reserves the right to reject any bid. The highest Bidder acknowledged by the auctioneer will be the Buyer. The auctioneer has absolute and sole discretion in the case of error or dispute with respect to bidding and, whether during or after the sale, to determine the successful Bidder, to re-open the bidding, to cancel the sale, or to re-offer and re-sell the motor car or any other lot in dispute. If any dispute arises after the sale, RM's sale record is conclusive. At RM's discretion, RM will execute order or absentee bids and accept telephone bids and online bids via rmsothebys.com as a convenience to clients who are not present at auctions; RM is not responsible for any errors or omissions in connection therewith. Prospective Bidders should also consult rmsothebys.com for the most up-to-date cataloguing of the motor cars or any other lots.

7.5. By participating in the sale, the Bidder represents and warrants that any bid placed by them, or on their behalf, is not the product of any collusive or other anti-competitive agreement and is otherwise consistent with federal and state antitrust law. RM may require such necessary financial references, guarantees, deposits, and/or such other security, at their absolute discretion, as security for any bid. Please bear in mind that RM is unable to obtain financial references over weekends or public holidays.

8. Purchase Price. The purchase price shall consist of the following:

8.1. the Hammer Price (defined below) of the motor car or any other lot, and

8.2. the applicable Buyers' Premium (defined below).

(Clauses 8 to 8.2 together "Purchase Price".)

9. Buyers' Premium.

9.1. In addition to the Hammer Price, the winning Bidder is required to pay RM a percentage of the Hammer Price, which RM retains as the Buyers' Premium for the purchase of each motor car or any other lot ("Buyers' Premium").

9.2. RMS North American auctions will have the following Buyers' Premiums:

9.2.1. In the event of a final Hammer Price of US\$250,000 and below on all motor car lots, RMS will receive a Buyers' Premium of 12%.

9.2.2. In the event of a final Hammer Price above US\$250,000 on all motor car lots, RMS will receive a Buyers' Premium of 12% on the first US\$250,000 and will receive a Buyers' Premium of 10% on the Hammer Price above US\$250,000.



Sotheby's

REGISTER TO BID



1981 924 Carrera GTS Clubsport
Chassis no. WPOZZZ93ZBS710038

1953 Porsche 356 Limousine Custom
Chassis no. 50146

1967 Porsche 911 S Coupe
Chassis no. 305860 S

1957 Porsche 356 A Carrera GT Speedster
Coachwork by Reutter
Chassis no. 83622

28 SEPTEMBER

THE TAJ MA GARAJ COLLECTION

OFFERED ENTIRELY WITHOUT RESERVE

DAYTON, OHIO

HEADQUARTERS +1 519 352 4575

FLORIDA +1 954 566 2209

NEW YORK +1 212 894 1562

CALIFORNIA +1 310 559 4575

rmsothebys.com
Collectors gather here.

BIDDERS' CONDITIONS OF BUSINESS

- 9.2.3. Buyers of all non-motor car lots, including but not limited to memorabilia, motorcycles, boats, trailers, jewelry, and clothing, are required to pay RMS a Buyers' Premium of 20% on the Hammer Price of those particular lots.
- 9.3. RMA North American auctions will have the following Buyers' Premiums:
- 9.3.1. RMA will receive a Buyers' Premium of 10% on all motor car lots.
- 9.3.2. Buyers of all non-motor car lots, including but not limited to memorabilia, motorcycles, boats, trailers, jewelry, and clothing, are required to pay RMA a Buyers' Premium of 15% on the Hammer Price of those particular lots.
- 9.4. RM European auctions will have the following Buyers' Premiums:
- 9.4.1. In the event of a final Hammer Price of €200,000 and below on all motor car lots, RM will receive a Buyers' Premium of 15% (plus VAT on the Buyers' Premium).
- 9.4.2. In the event of a final Hammer Price above €200,000 on all motor car lots, RM will receive a Buyers' Premium of 15% (plus VAT on the Buyers' Premium) on the first €200,000 and will receive a Buyers' Premium of 12.5% (plus VAT on the Buyers' Premium) on the Hammer Price above €200,000.
- 9.4.3. Buyers of all non-motor car lots, including but not limited to memorabilia, motorcycles, boats, trailers, jewelry, and clothing, are required to pay RM a Buyers' Premium of 20% (plus VAT on the Buyers' Premium) on the Hammer Price of those particular lots.
- 9.5. RMS London, United Kingdom, auctions will have the following Buyers' Premiums:
- 9.5.1. In the event of a final Hammer Price of £200,000 and below on all motor car lots, RMS will receive a Buyers' Premium of 15% (plus VAT on the Buyers' Premium).
- 9.5.2. In the event of a final Hammer Price above £200,000 on all motor car lots, RMS will receive a Buyers' Premium of 15% (plus VAT on the Buyers' Premium) on the first £200,000 and will receive a Buyers' Premium of 12.5% (plus VAT on the Buyers' Premium) on the Hammer Price above £200,000.
- 9.5.3. Buyers of all non-motor car lots, including but not limited to memorabilia, motorcycles, boats, trailers, jewelry, and clothing, are required to pay RMS a Buyers' Premium of 20% (plus VAT on the Buyers' Premium) on the Hammer Price of those particular lots.
- 9.6. For those Bidders utilizing the online service Live Auctioneers for any RM auction, in addition to the applicable Buyers' Premium, an additional 2% of the Hammer Price will be charged to the Buyer of a motor car lot, and an additional 3% of the Hammer Price will be charged to the Buyer of a non-motor car lot, including but not limited to memorabilia, motorcycles, boats, trailers, jewelry, and clothing.
- 10. Taxes.**
- 10.1. The Buyer is responsible to pay all city, state, federal, provincial, territorial, and any and all other taxes due for which the Buyer does not qualify as exempt, subject to RM verification; proof of exemption is the Buyer's responsibility. The Buyer is responsible for any applicable duty, import tariffs, charges, or any and all other required payments that are due upon the import of the motor car or any other lot to its final destination.
- 10.2. Although by no means an exhaustive list, please be aware of the tax scenarios below.
- 10.2.1. For auctions held in the United States, if the Buyer of a motor car or any other lot resides in an American state in which RM is registered to collect/remit sales tax, RM is required to collect/remit sales tax on the purchase of that motor car or any other lot. RM is registered to collect/remit sales tax in the following states: California, Florida, Indiana, Pennsylvania, Arizona, New York, and Michigan. RM reserves the right to collect/remit sales tax from residents from other jurisdictions if RM deems the collection/remittance of tax necessary.
- 10.2.2. For auctions in the EU, according to the EU VAT Directive, motor cars that have been in use for no more than 6 months or that have been driven for no more than 6,000 kilometers are considered new means of transport and will be subject to VAT. Payment of VAT is the responsibility of the Buyer. Where applicable, RM may take a deposit from the Buyer equal to the amount of VAT due, which will be refunded upon receiving satisfactory evidence that the motor car has been transported to and registered in another EU country.
11. No Legal or Tax Advice. This agreement is an important legal document. The Bidder acknowledges that the Bidder has had the opportunity to consult an attorney before signing this agreement and has signed this agreement after having the opportunity to consult with an attorney of their own choosing. Notwithstanding any references to any transactions or arrangements in this agreement, or any contemporaneous written, oral, or implied understandings of the Parties relating to the subject matter of this agreement, RM has not provided legal or tax advice or tax planning services to the Bidder or for the Bidder's benefit in connection with the transactions contemplated by this agreement, and no one at RM has acted as the Bidder's attorney or tax advisor. It is the Bidder's responsibility to satisfy themselves and comply with all applicable tax, duty, or any and all other payments associated with the purchase of a motor car or any other lot at an RM auction.
- 12. Payment.**
- 12.1. Subject to fulfillment of the Contractual Obligations, on the fall of the auctioneer's hammer (or equivalent device or mechanism), the contract between the Consignor and the Bidder is concluded.
- 12.2. The value of the last accepted bid upon the fall of the auctioneer's hammer (or equivalent device or mechanism) is the Hammer Price ("**Hammer Price**").
- 12.3. Payment is due in full on or before 5:00 p.m. of the next business day ("Payment Deadline"), and payment is to be made to RM.
- 12.4. For RM North American auctions, all payments must be in the form of cash or certified funds unless other arrangements have been approved in advance. Cash payments will be reported according to U.S. federal government requirements.
- 12.5. For RM United Kingdom and European auctions, all payments must be in the form of wire transfer unless other arrangements have been approved in advance.
- 12.6. RM is not obligated to release the motor car or any other lot to the winning Bidder until the winning Bidder has met all of the Contractual Obligations and paid the Purchase Price plus applicable taxes.
- 12.7. In the event that the winning Bidder does not pay any portion of the Purchase Price plus applicable taxes by the Payment Deadline, the Bidder agrees to and acknowledges the following: If RM elects to pay the Consignor any portion of the Purchase Price plus applicable taxes, RM shall have all of the rights of the Consignor to pursue the Buyer for any amounts paid to the Consignor, whether at law, in equity, or under these Conditions of Business. The Bidder hereby authorizes RM to deduct the Purchase Price plus applicable taxes from the Bidder's cash deposit or to charge this amount to the credit card that the Bidder has provided. If the Bidder's cash deposit and/or credit card payment does not cover the Purchase Price plus applicable taxes, in addition to other remedies available by law, RM reserves the right to impose, from the Payment Deadline until the full Purchase Price plus applicable taxes has been made by the Buyer, a late charge of 10% interest per annum on the (1) Purchase Price plus applicable taxes, (2) maximum published Sellers' Commission, (3) Buyers' Premium, (4) applicable expenses, (5) any collection costs, attorneys' fees, and court costs incurred to enforce payment, and (6) other damages.
- 13. Reserves.** Motor cars or any other lots not marked as "no reserve" (or similar) are subject to a reserve bid set by the Consignor. When a motor car or any other lot is sold subject to such a reserve bid, the auctioneer may bid on the Consignor's behalf in an amount not to exceed the amount of the reserve bid.
- 14. Absentee and Telephone Bidding.** Absentee and telephone bidding are services provided by RM for the Bidder's benefit, and RM cannot be held responsible for errors or omissions with respect to the bidding process, including failure to execute any bid. By submitting one or more bids, the Bidder has entered into a binding contract to purchase each motor car or any other lot if the Bidder's bid is successful. If the Bidder's bid is successful, the Bidder is to pay the Purchase Price plus applicable taxes, including the Buyers' Premium and sales tax, if not otherwise exempt. It is the Bidder's responsibility to provide proof of exemption from sales tax. By participating in telephone bidding, the Bidder acknowledges that RM has the right to record all telephone calls.
- 15. Cancellation/Rescission of Auction.** RM will use reasonable efforts to avoid cancellation/rescission; however, RM has the sole discretion to cancel/rescind the auction and will not be liable to the Bidder for any losses or damages resulting from the cancellation/rescission if RM believes the following events have occurred or have a reasonable probability of occurring:



Auctions

NOW INVITING
CONSIGNMENTS



THE MUCKEL COLLECTION

A PRIVATE COLLECTION OF OUTSTANDING BRASS ERA MOTOR CARS

10-11 OCTOBER

HERSHEY

VIEW ADDITIONAL LOTS ONLINE

HEADQUARTERS +1 519 352 4575

FLORIDA +1 954 566 2209

NEW YORK +1 212 894 1562

INDIANA +1 260 927 9797

CALIFORNIA +1 310 559 4575

RM Auctions, Inc. Lic. No. AY002018/Licensed Auctioneer Brent Earlywine #AU005096

rmsothebys.com
Collectors gather here.

BIDDERS' CONDITIONS OF BUSINESS

- 15.1. Force Majeure events including but not limited to:
- 15.1.1. Any natural disaster, which despite reasonable efforts, restricts RM from holding the auction;
 - 15.1.2. Structural damage to the auction venue prior to the auction, which despite reasonable efforts, restricts RM from holding the auction; and
 - 15.1.3. Any terrorist event, which despite reasonable efforts, restricts RM from holding the auction.
- 15.2. Government/court actions, orders, injunctions, regulations, laws, or non-compliance with applicable rules, regulations, or laws to hold an auction that necessitate a cancellation.
- 16. Cancellation/Rescission of Motor Car or Any Other Lot.** RM will use reasonable efforts to avoid cancellation/rescission; however, RM has the sole discretion to cancel/rescind the sale of a motor car or any other lot and will not be liable to the Bidder for any losses or damages resulting from the cancellation/rescission if RM believes the following events have occurred or have a reasonable probability of occurring:
- 16.1. RM opines that the motor car or any other lot has been intentionally and materially misrepresented by the Consignor;
 - 16.2. RM opines that physical damage to the motor car or any other lot, which cannot be sufficiently repaired prior to the auction, occurred after this agreement was signed;
 - 16.3. RM is served with a lawsuit from a third party in relation to the motor car or any other lot;
 - 16.4. RM faces significant reputational damages that would cause monetary damages for selling the motor car or any other lot;
 - 16.5. Material issues regarding title, registration, or transfer of ownership that cannot be reasonably cured;
 - 16.6. Material issues regarding the provenance, merchantability, or authenticity of the motor car or any other lot that cannot be reasonably cured;
 - 16.7. Government/court actions, orders, injunctions, regulations, laws, or non-compliance with applicable rules, regulations, or laws to sell the motor car or any other lot at auction that necessitate a cancellation; or
 - 16.8. If there are legitimate claims, accusations, notices, or similar communications made by the Buyer in regard to their purchase of a motor car or any other lot not being authentic, being misrepresented, having an encumbered title or registration, having undisclosed material issue, or having a similar claim, RM has the right to retain the Buyer's funds on account and be the arbitrator as to the merit of the Buyer's claims and to cancel the sale of the motor car or any other lot and reimburse the payment to the Buyer if RM deems the Buyer's claims to be valid.
- 17. Online Services Are "As Is" and "As Available."**
- 17.1. Bidders may be able to bid via websites, telephone services, applications, and tools (collectively "Services").
 - 17.2. RM tries to keep the Services safe, secure, and functioning properly, but RM cannot guarantee the continuous operation of or access to the Services. Bid update and other notification functionality may not occur in real time. Such functionality is subject to delays beyond RM's control.
- 17.3. Bidders agree that they are making use of the Services at their own risk and that they are being provided to Bidders on an "AS IS" and "AS AVAILABLE" basis. Accordingly, to the extent permitted by applicable law, RM excludes all expressed or implied warranties, terms, and conditions, including but not limited to implied warranties of merchantability, fitness for a particular purpose, and non-infringement.
- 18. Currency Display.** RM may use a currency display in the salesroom for informational purposes only. The currencies listed on the currency converter are not real-time conversions pegged to market rates and are not to be relied on by anyone. Errors and inaccuracies may occur in the operation of the currency converter. To be clear, the bid price stated by the auctioneer is the prevailing and binding bid price.
- 19. Bank Letter.** Please note that in order to register to bid at an RM sale, RM requires that all Bidders provide a Bank Letter. All Bank Letters must be written on bank letterhead. Please note that RM may waive this requirement at its sole discretion.
- 20. Credit Card Hold and Pre-authorization.**
- 20.1. Please note that in order to register to bid at an RM sale, RM requires a hold and pre-authorization to be placed on the Bidder's credit card, which is dependent on the particular auction as listed in clause 20.2 ("CC Hold"). If the Bidder fails to pay for a motor car or any other lot purchased on or before 5:00 p.m. of the next business day following the auction, the Bidder acknowledges that their credit card will be charged the applicable CC Hold for the missed payment; please note that the Bidder is still bound to pay their remaining balance. The CC Hold will not be charged to their credit card if the Bidder makes full payment on or before 5:00 p.m. of the next business day following the auction. If the Bidder does not purchase a motor car or any other lot, their credit card will not be charged. If their credit card is not to be charged, the CC Hold should fall off their credit card within 10 business days, depending on their credit card company. Please note that RM may waive this requirement at its sole discretion.
 - 20.2. A CC Hold as outlined below will be placed on the Bidder's credit card:
 - 20.2.1. A US\$5,000 CC Hold for RMS North American auctions;
 - 20.2.2. A US\$2,000 CC Hold for RMA North American auctions;
 - 20.2.3. A €5,000 CC Hold for RM European auctions; and
 - 20.2.4. A £5,000 CC Hold for RMS London, United Kingdom, auctions.
- 21. Title Transfer.**
- 21.1. For RM's North American auctions, in an effort to ensure all titles are free and clear of liens or encumbrances, RM manages the process of title reassignment on behalf of the Buyer. Buyers will receive titles in the mail as soon as possible following the auction with a target of a maximum of 20 business days following the auction; however, please note that for reasons beyond RM's control, including any delays in lien releases by lien holder(s) and/or delays by Department of Motor Vehicles (or equivalent) in certain states, there are instances where the Buyer may not receive the title within 20 business days and, in those circumstances, RM will work to provide the titles to the Buyer as soon as possible. A US\$75 administration fee or its equivalent in local currency of the auction location (US\$85 in the State of California) will be assessed per motor car purchased, but this fee will not apply to nostalgia lots.
 - 21.1.1. If a motor car or any other lot is rendered "Title in Transit", it is unlikely that the Buyers will receive the title in the mail within 20 business days following the auction; however, RM will work to provide the titles to the Buyer as soon as possible.
 - 21.1.2. The Buyer acknowledges that delays in transferring titles due to delays at government Motor Vehicle departments happen from time-to-time and, the Buyer will hold RM harmless from any allegations of damages arising out of government delays.
 - 21.2. For RM European and London, United Kingdom auctions, RMS will use its best efforts to ensure that all titles are free and clear of liens and encumbrances. Where possible, RMS will also assist with the process of title reassignment on behalf of the Buyer. RMS cannot however be held responsible for the successful completion of this procedure due to the various regional rules and guidelines.
- 22. Removal of Purchased Motor Car or Any Other Lot.**
- 22.1. For RM North American and European auctions, all purchased motor cars, including motorcycles, boats, and trailers, must be removed from the auction site by the next business day by 5:00 p.m. in the applicable time zone where the auction is held ("RM Removal Deadline").
 - 22.1.1. Specifically, for RM North American auctions:
 - 22.1.1.1. If a motor car (including motorcycles, boats, and trailers) is not removed by the RM Removal Deadline, the Buyer will be charged a removal fee of up to US\$600 and a daily storage fee of up to US\$30 until the motor car (including motorcycles, boats, and trailers) is removed.
 - 22.1.1.1.1. Please note that for RM auctions in Auburn, Indiana, no removal fee will apply.
 - 22.1.2. Specifically, for RM European auctions:
 - 22.1.2.1. The Buyer will be charged a removal fee of up to €600 plus VAT per motor car, and a daily storage fee of up to €40 plus VAT per motor car until the motor car (including motorcycles, boats, and trailers) is removed.
 - 22.1.2.2. Specifically, if a boat lot is not removed by the RM Removal Deadline, RM will remove the boat lot, and the Consignor is required to pay RM a removal fee plus VAT per boat lot and a daily storage fee plus VAT per boat lot. The removal fee and daily storage fee for a boat lot will be determined based on the size of the boat lot and therefore cannot be confirmed until the boat lot is consigned.



Sotheby's

NOW INVITING
CONSIGNMENTS



EARLY HIGHLIGHT
1969 Lamborghini Miura P400 S
Coachwork by Bertone
Chassis no. 4245

Delivered new to Germany, this Miura P400 S was purchased by its second owner in 1974 and has remained with him ever since. Presented in unrestored and highly original condition, this is undoubtedly one of the most exciting Miuras offered in recent memory.

24 OCTOBER - **NEW DATE & VENUE**

LONDON

CONSIGNMENTS INVITED THROUGH 6 SEPTEMBER
OLYMPIA LONDON, KENSINGTON, LONDON

HEADQUARTERS +1 519 352 4575
UK +44 (0) 20 7851 7070
NEW YORK +1 212 894 1562
CALIFORNIA +1 310 559 4575

rmsothebys.com
Collectors gather here.

BIDDERS' CONDITIONS OF BUSINESS**22.2. For RMS London, United Kingdom, auctions:**

22.2.1. All purchased motor cars, including motorcycles, boats, and trailers, will be removed and taken to the CARS Europe storage facility located in either Chedburgh, Suffolk, United Kingdom, or Fair Oaks Chobham, United Kingdom, by the next business day by 12:00 p.m. in the applicable time zone where the auction is held.

22.2.2. The Buyer will be charged a removal fee of up to £600 plus VAT per motor car and a daily storage fee of up to £40 plus VAT per motor car until the motor car (including motorcycles, boats, and trailers) is removed.

22.3. Regarding the collection of any non-motor car lots, including but not limited to memorabilia, jewelry, and clothing, from the auction site: Once the Buyer has made payment by the Payment Deadline, a direct shipping company will contact the Buyer. Please note that a reasonable memorabilia removal and storage fee will apply.

22.4. Please note that the Buyer is required to insure their motor car or any other lot while the motor car or any other lot is being stored on their behalf.

23. Legal Action.

23.1. For RM North American auctions, in the event that either party brings action against the other, arising from or relating to this auction, the prevailing party, as determined by the court, shall be entitled to recover its reasonable attorneys' fees and costs. Jurisdiction for any action brought shall lie exclusively in a court of competent jurisdiction in the judicial district in which the auction is located.

23.2. For RM European auctions:

23.2.1. These Bidders' Conditions of Business (and any dispute or claim relating to them, their subject matter, their enforceability, or their termination [including non-contractual claims]) are to be governed by and construed in accordance with English law.

23.2.2. The courts of England and Wales shall have jurisdiction to settle any claim, dispute, or issue, whether arising out of or in connection with these Bidders' Conditions of Business or otherwise (including non-contractual claims). In the case of a dispute that is the subject of a claim by RM, such jurisdiction shall be non-exclusive. In any other case, such jurisdiction shall be exclusive, and the Buyer and Consignor agree that it will not institute proceedings in the courts of any country other than England and Wales.

23.3. For RMS' Paris auctions:

23.3.1. These Bidders' Conditions of Business (and any dispute or claim relating to them, their subject matter, their enforceability, or their termination including non-contractual claims) are to be governed by and construed in accordance with French law.

23.3.2. The courts of France shall have jurisdiction to settle any claim, dispute, or issue, whether arising out of or in connection with these Bidders' Conditions of Business or otherwise (including non-contractual claims). In the case

of a dispute that is the subject of a claim by RM, such jurisdiction shall be non-exclusive. In any other case, such jurisdiction shall be exclusive, and the Buyer and Consignor agree that they will not institute proceedings in the courts of any country other than France.

24. Packing and Shipping. RM is not responsible for the acts or omissions in our packing or shipping of purchased motor cars or any other lots or of other carriers or packers of purchased motor cars or any other lots, whether or not recommended by RM. Packing and handling of purchased motor cars or any other lots are at the entire risk of the Buyer.

25. Data Use. The Bidders agree to allow RM to use their personal information in accordance with RM's Privacy Policy. RM uses your personal information to provide services specifically tailored toward your requirements and to treat you in a personal way; to fulfill your agreements regarding the consignment and purchase of items at RM auctions and private sales; to provide you with information on upcoming sales; to carry out analysis and market research; to undertake targeted online advertising; to send status updates and service communications; to improve our websites, products, and services; to provide payment services; and for management and administrative purposes. The full Privacy Policy can be found at the bottom of the RM website homepage under the Privacy & Terms tab. If you wish to ask any questions regarding the use of your personal information, to request a full accounting of what personal information is on file with RM, or to unsubscribe to any services or purge your personal information from RM's systems, please email privacy@rmsothebys.com.

26. Anti-Money Laundering. The Bidder agrees to provide all information and assistance reasonably requested by RM to comply with RM's internal Anti-Money Laundering process and to comply with any and all Anti-Money Laundering Laws and Regulations in force in the jurisdiction in which the auction is held.

27. Entire Agreement: This document shall be binding upon the parties and their respective heirs, personal representatives, and assigns. Except as otherwise expressly provided herein, these Conditions of Business shall not be modified, except in writing. Whenever used in these Conditions of Business, as the contract requires, the singular number shall include the plural, the plural number shall include the singular, the masculine gender shall include the feminine and neuter, the feminine gender shall include the masculine and neuter, and the neuter gender shall include the masculine and feminine.

28. Motor Car or Any Other Lot Exhaust Warning. Operating, servicing and maintaining a passenger vehicle or off-road vehicle can expose you to chemicals including engine exhaust, carbon monoxide, phthalates, and lead, which are known to the State of California to cause cancer and birth defects or other reproductive harm. To minimize exposure, avoid breathing exhaust, do not idle the engine except as necessary, service your vehicle in a well-ventilated area and wear gloves or wash your hands frequently when servicing your vehicle. For more information go to www.P65Warnings.ca.gov/passenger-vehicle.

FOR RM CALIFORNIA AUCTIONS SPECIFICALLY:

29. Notice to Buyers as Required by the California Department of Motor Vehicles Code Section 11729. Failure of RM to comply with the terms of this agreement may be in violation of statute, which could result in criminal or administrative sanctions, or both. If you feel RM has not complied with the terms of this agreement, please contact an investigator of the Department of Motor Vehicles.

30. Contract Cancellation Agreement. In the event of a successful bid, if a motor car or any other lot has a combined hammer price and Buyers' Premium equaling less than US\$40,000, under the Car Buyer's Bill of Rights (FFVR 35), RM is required to offer a 2-day contract cancellation option agreement to the successful Buyer. If the Buyer exercises this contract cancellation option, RM is obligated to return any funds paid by the Buyer and cancel the sale. If the sale is canceled, RM is under no obligation to pay the Consignor for the motor car or any other lot, and the motor car or any other lot will be deemed to have not sold.

FOR RM EUROPEAN AUCTIONS SPECIFICALLY:**31. Motor Car or Any Other Lot Under Temporary Import.**

31.1. A temporary import bond is used in all EU sales. If a motor car or any other lot is brought into the EU from a country outside of the EU, the motor car or any other lot must be placed on either RM's bond in the United Kingdom or one of RM's nominated customs agencies for Paris, Monaco, or Italy. Fees and charges vary from sale to sale, and for some countries, this is also determined by the value of the motor car or any other lot.

31.2. Motor cars or any other lots subject to temporary importation restrictions cannot be discharged from RM's custody without the completion of customs procedures and until full payment has been received. Customs charges will be levied appropriately depending on each individual scenario and will be payable directly to the relevant authorities, which RM will provide the details of as and when necessary.

31.3. Should the Buyer decide for the motor car or any other lots to remain in the EU when purchased, the Buyer is responsible to pay any and all import fees for the motor car or any other lots.

32. Translated Bidders' Conditions of Business. If there is a contradiction due to translation in our Bidders' Conditions of Business, please note that the English version of RM's Bidders' Conditions of Business will supersede.

FOR RMS' PARIS AUCTIONS SPECIFICALLY:

33. Guarantee. Please note that RMS has placed a guarantee with OBE Insurance (Europe) Limited, a company incorporated in England with registered number 1761561 ("OBE"), Plantation Place, 30 Fenchurch Street, London, EC3M 3BD, to secure availability of sale proceeds as required by law.



Sotheby's

NOW INVITING
CONSIGNMENTS

RM SOTHEBY'S IN PARTNERSHIP WITH FORMULA 1® PRESENTS
EARLY HIGHLIGHTS FOR THE FIRST COLLABORATIVE AUCTION OF ITS KIND



2002 Ferrari F2002
Chassis no. 219

Michael Schumacher raises his fist in victory at FORMULA 1 GRAN PREMIO DI SAN MARINO 2002
Photo courtesy of Motorsport Images



2017 Porsche 918 Spyder
Chassis no. WPOZZZ91ZFS800619



1990 Ferrari F40
Chassis no. ZFFGJ34B000084467



2001 Lamborghini Diablo GT
Chassis no. ZA9DE21A0YLA12555



30 NOVEMBER
ABU DHABI
CONSIGNMENTS INVITED THROUGH 23 OCTOBER

HEADQUARTERS +1 519 352 4575
UK +44 (0) 20 7851 7070
NEW YORK +1 212 894 1562
CALIFORNIA +1 310 559 4575

The F1 FORMULA 1 logo, F1 logo, FORMULA 1, FORMULA ONE, F1, FIA FORMULA ONE WORLD CHAMPIONSHIP, GRAND PRIX, PADDOCK CLUB and related marks are trademarks of Formula One Licensing BV, a Formula 1 company. Licensed by Formula One World Championship Limited, a Formula 1 company. All rights reserved.

rmsothebys.com
Collectors gather here.



WHERE THE WORLD'S FINEST CARS OF YESTERDAY LIVE TODAY!

The Museum is located in the original 1930s national headquarters of the legendary, world-renowned Auburn Automobile Company. Over 120 classic, antique, vintage, and special-interest cars are displayed with various other automotive-related exhibits on three floors.



WE ARE PROUD TO BE THE
OFFICIAL TITLE SPONSOR OF THE AUBURN
CORD DUESENBERG AUTOMOBILE MUSEUM

45TH ANNIVERSARY CELEBRATION

Visit our friends at the Auburn
Cord Duesenberg Automobile
Museum.

Show your Auburn Fall auction
admission pass from
29 August 2019 to 31 December
2019 to receive \$2.00 OFF your
admission and 10% OFF in the
museum store!

1600 SOUTH WAYNE STREET
AUBURN, IN • 46706

www.automobilemuseum.org

1600 South Wayne Street • Auburn, IN • 46706
+1 260 925 1444 • www.automobilemuseum.org
Open Daily (Eastern) 9:00 a.m. - 5:00 p.m.



DirtFish

RALLY SCHOOL.



**DIRTFISH
RALLY HOT LAPS
COMING TO
AUBURN AUCTION
PARK 8/29-9/1**

VISIT WWW.DIRTFISH.COM FOR DETAILS



**OPEN
7 DAYS
PER WEEK**



**EVERY
SKILL
LEVEL**



**TEAM
BUILDING
EVENTS**



**XBOX
SIMULATOR
LOUNGE**



VENDOR CATEGORY	COMPANY/ VENDOR NAME	BOOTH NUMBER
MAGAZINES	HEMMINGS MOTOR NEWS	A1000-1005
BOOKS	PJ'S AUTO LITERATURE	A1006-1012
GAS PUMPS	HIGH STREET PERFORMANCE	A1020-1022
MISC. AUTOMOTIVE	HIGH STREET PERFORMANCE	A1246
CHROME PLATING	ADVANCED PLATING INC	A1023-1025
ANTIQUES	STANLEY, TED	A1026-1029
INSURANCE	MOBILE INSURANCE AGENCY	A1030
MISC. NON-AUTOMOTIVE	LUDWIG, SAM	A1031
GAS STATION ITEM	HANISCH, SCOTT	1031-1033
TOOLS	CARPENTER, LARRY	A1037-1040
MISCELLANEOUS	HIXSON AUCTION SERVICE	A1041-1043
USED CAR PARTS	DECARE, ALGER & RHONDI	A1044-1045, 1067-1068
USED CAR PARTS	RICHARD, STEVE	A1046
ANTIQUES	TOM, THOMAS	A1047-1049
MISC. MEMORABILIA	ERICKSON, JERRY	1050-1052
MISC. AUTOMOBILIA	DOCKERY, JOHN	A1053-1055
USED CAR PARTS	ADAMS, JOE	A1056
SIGNS	CLASSIC STREET SIGNS	A1058-1061
ANTIQUE TOYS	WIARD, BOB	A1063-1065-1089
MISCELLANEOUS	RAPPUHN, WILLIAM	A1066
PORCELAIN NEON SIGNS	BOB SAIN	A1069-1074
MISCELLANEOUS	PALANCI, HENRY	A1076
FABRICATION	RECKON PLATING INC	A1077-1078
ANTIQUE TOYS	RANDY'S TOY SHOP	A1083-1086
FASTENERS	MILLER, LEO	A1091-1092, A1116
WAXES & CLEANER	CALIFORNIA CUSTOM PRODUCTS	A1093-1094
MISC. NON-AUTOMOTIVE	ZILIS BY BRANDY	A1095
METAL SIGNS	STREETLIGHT AUTO SALES	A1096-1097
MISCELLANEOUS	XUE QIN LI	A1101-1105
CLOTHING & HATS	LAID-BACK USA	A1107-1111
SIGNS	KERR, RYAN	A1112
MISC. MEMORABILIA	LAUGHLIN, DAVID (TONY)	A1117-1120
ANTIQUE TOYS	HATHAZY, TOM	1121-1122
GOLF CARTS	RIDGE MOTOR COMPANY, INC.	A1131-1137

VENDOR CATEGORY	COMPANY/ VENDOR NAME	BOOTH NUMBER
USED CAR PARTS	T.S. IMPORTED AUTOMOTIVE	A1140
METAL SIGNS	TRIO	A1141-1145
SIGNS	GROVES, CHRIS	A1147-1150
MISC. AUTOMOTIVE	EVERYTHINGS CUSTOM	A1151-1154
MISCELLANEOUS	BACKWOODS SPEED SHOP	A1155-1159
LICENSE PLATES/FRAMES	COLLINS, RICHARD	A1161
SIGNS	DIAMOND, KIM	A1162-1164
CAR MANUALS	ROTH AUTO BOOKS	A1165-1170
MISC. AUTOMOTIVE	SROKA, RICHARD & LINDA	A1173-1174
PONTIAC	CAPN JACK	B2398-2400, 2412-2414
HUBCAPS	HUBCAPS TO GO	A1180-1188, A1201-1212, 1227-1229
ANTIQUES	LOOKING BACK ANTIQUES	A1189-1190
GAS STATION ITEMS	TOM'S ANTIQUES & COLLECTABLES	A1191-1192
MISC. AUTOMOTIVE	NO MORE WALLS MINISTRY	A1193-1195
MISC. MEMORABILIA	CRAFT COINS	A1196
MISC. AUTOMOTIVE	MAY, EDDIE	A1213-1218
YARD ART	HETRICK, MARYANN	A1225
NOT-FOR-PROFIT	CENTER FOR NON-VIOLENCE	A1226
JEWELRY	LIDDY, KAT	A1230
MISCELLANEOUS	CLOUGH, ANGELL	A1231
USED CAR PARTS	BRADSHAW, LOUIS	A1232, 1255
NEON SIGNS	CHUCK'S ANTIQUES	A1234-1236
SIGNS	SIMS AUTO	A1237-1240
DIECAST CARS	SCHOONOVER, JOHN	A124-1242
USED CAR PARTS	OLD CARS & PARTS	A1243
AUTOMOTIVE BADGES	SKINNER, GARY	A1247
ANTIQUES	FRANK, JEFFREY	A1251-1254
ANTIQUES	CHUCK'S ANTIQUES	A1234-1236, 1256-1258
AUTOMOBILIA	HOYT, BOB	A1248
ANTIQUE TOYS	PATTEN, JACK	A1080
SIGNS	BANKS, NICK & KAREN	B2000-2001
MISC. AUTOMOTIVE	WISNIEWSKI, DAN	B2002-2006
BUMPERS	THE BUMPER BOYZ CO	B2007-2015
USED CAR PARTS	IMPULSE OF BEDFORD	B2016-2020



VENDOR CATEGORY	COMPANY/ VENDOR NAME	BOOTH NUMBER
USED CAR PARTS	RON DECKER & ROGER LEWIS	B2028-2030, 2047
MISCELLANEOUS	CUMMINGS, DAN	B2031
MISC. AUTOMOTIVE	FREEMAN'S MUSCLE MOTOR SPORTS	B2032-2035, 2051, CC109-112
MISC. MEMORABILIA	PEEL, BRETT	B2038-2041, 2054-2057
USED CAR PARTS	SMITH, ERIC	B2048-2050
USED CAR PARTS	CIBULA, MICHAEL	B2058
MISCELLANEOUS	SNOWDEN, ED	B2060-2063
USED CAR PARTS	HARRINGTON/DAUGHERTY, GUS/RICKIE	B2064-2065
MISCELLANEOUS	ALLEN, THOMAS	B2066-2069
ANITQUES	ESTES, JOE & MARGARET	2070-2071
USED CAR PARTS	DEPEW, RICK	B2075, 2091
HUBCAPS	BOB'S HUBCAPS	B2076-2079
MISCELLANEOUS	LANE AUTOMOTIVE	B2080-2083
MISCELLANEOUS	CROSS, JOHNNY	B2084-2088
MISCELLANEOUS	GIRTON, DON	B2093-2095
USED CAR PARTS	S & J ENTERPRIZES	B2096-2100
USED CAR PARTS	WELLS, BILL	B2101-2103
MISCELLANEOUS	GREENE, LARRY	B2104-2105
MISC. AUTOMOTIVE	KAISER, TIMOTHY	B2106
USED CAR PARTS	KAISER, JEREMY	B2107-2109
USED CAR PARTS	STONER, DAN	B2110-2111
GAS STATION ITEMS	TERRY, BILL	B2112-2116
PONTIAC	WILKINSON, GREGG	B2119
MISC. AUTOMOBILIA	HULL, JEFF	B2123-2125
MISCELLANEOUS	HULBERT, WARREN	B2127
MISCELLANEOUS	STAHL, RICK & MARGE	B2128-2129, 2144-2145
GAS STATION ITEMS	WALTER, KEVIN	B2132-2137
USED CAR PARTS	YODER, BUD	B2143, 2159
MISC. AUTOMOTIVE	GONSER, RICK	B2146-2147
MISCELLANEOUS	FUHRER, JASON	B2152-2154
USED CAR PARTS	RED BARN COLLECTOR CAR PARTS	B2160-2165, 2180
USED CAR PARTS	VARNEY, WILLIAM	B2170-2175, 2186-2191
ANTIQUA BOAT MOTORS	THE OUTBOARD GUY	B2176-2179
MISCELLANEOUS	HUFF, BOB	B2181

VENDOR CATEGORY	COMPANY/ VENDOR NAME	BOOTH NUMBER
MISCELLANEOUS	SHIFFLETT, JACK	B2192-2195
USED CAR PARTS	HARGRAVES, BOB	B2206-2207
MISCELLANEOUS	BOOKS, GARRY	B2208-2210
MISCELLANEOUS	MARKS, DAVID	B2220-2222
USED CAR PARTS	FEY, TIMOTHY	B2223
NEW OLD STOCK MODEL A	BATTLEFIELD MODEL A PARTS	B2224-2225, 2240-2241
MISCELLANEOUS	CARY, CAMERON	B2234-2235
PETROLIANA	KIMPEL, DAVE	B2238-2239, 2254-2255
USED CAR PARTS	STEVENS, PETE	B2242-2243
MISCELLANEOUS	BARNES, BILL	B2244-2245
ANTIQUES	HAY, MARK	B2256-2257, 2271
ANTIQUES	LANDERS, GEORGIA	B2259
MISC. NON-AUTOMOTIVE	RORICK, JOAN & JOHN	B2260
ANTIQUES	SWINCICKI, WILLIAM	B2268-2269
USED CAR PARTS	VANDERMEER, KEN	B2272-2275
USED CAR PARTS	MARVEL, TOM	B2276-2278
USED CAR PARTS	HESS, RUSS	B2279-2281
MISCELLANEOUS	HOSKINS, JOHNNIE	B2282-2283
USED CAR PARTS	LEMONS, BILL	B2284-2287, 2296-2299
LICENSE PLATES/FRAMES	RAGSDALE, JAMES (ED)	B2289-2290
MISCELLANEOUS	HIPP, BOB	B2291-2293
ANTIQUES	MILLER, BRAD	B2294
MUSCLE CAR PARTS	HERNDON, RODNEY	B2302-2303
USED CAR PARTS	STOPHER, BRUCE	B2305
TOOLS	MILLER, DOYT	B2306
ANTIQUES	JAMES, BILL	B2308-2312
LICENSE PLATES	ROGERS, KEVIN	B2314-2315
MISCELLANEOUS	GRECO, PAMELA	B2316-2317
MISCELLANEOUS	MARTIN, LACY	B2318
MISCELLANEOUS	BEST, TERRY	B2319-2320
MISCELLANEOUS	KIEL, BOB	B2322
MISC. AUTOMOTIVE	FEBER, DAVID	B2324-2326
LICENSE PLATES	ROGERS, KEVIN	B2329
SIGNS	WETZEL, DENNIS	B2332-2335
MISCELLANEOUS	TALLEY, RANDY	B2336-2337



VENDOR CATEGORY	COMPANY/ VENDOR NAME	BOOTH NUMBER
SIGNS	KEETCH, DAVID	B2344-2345
MISCELLANEOUS	BALLARD, MIKE	B2346-2349
MISCELLANEOUS	ALEXANDER, TIM	B2350-2363
MISCELLANEOUS	GREENBAUM, JASON	B2364
MISCELLANEOUS	FRASER, KRISTINA	B2368-2369
MISC. AUTOMOTIVE	MILES, RANDY	B2372, 2386
GM NEW OLD STOCK	GM RESTORATION PARTS SPECIALIST	B2376-2377, 2390-2391
DECALS & GRAPHICS	BLEIL'S NOSTALGIA DECALS	B2378-2380
MISCELLANEOUS	QUAL KROM-GREAT LAKES PLANT	B2381-2382
AUTOMOBILIA	PUMP BOYS & DINETTES	B2387-2389,2375
MISC. AUTOMOTIVE	WOLOSZYNEK, PAUL	B2392-2395
USED CAR PARTS	PAPER & PARTS	B2402-2405, 2416-2419
ANTIQUES	GOULDSBERRY, BETTE	B2406-2407
ANTIQUES	SECOND CHANCE ANTIQUES	B2408-2409
USED CAR PARTS	FELLER, SCOTT	B2425
MISCELLANEOUS	LASH, LARRY	B2426-2428, 2440-2442
PORCELAIN SIGNS	SIMON, ENOCH	B2431-2433, 2445-2447
USED CAR PARTS	VREELAND, PHIL	B2434-2436
USED CAR PARTS	MIDTGARD, BRENT	B2437-2439
MISC. MEMORABILIA	WEST POINT AUTOMOTIVE	B2448-2449
MISC. AUTOMOTIVE	WARNER, RICK	B2453-2454,2467-2469
MISCELLANEOUS	BRIDEGAN, ELVIN	B2460-2461
PETROLIANA	HITZEMAN'S RESTORATION	B2462-2463
MISC. AUTOMOTIVE	KINZER, KEN	B2464
MISCELLANEOUS	BAIRD IMPTON, DEE	B2472-2575
PETROLIANA	SNYDER, STEVE	B2476-2478, 2491-2492
MISC. AUTOMOBILIA	FRAIN, RANDY	B2480-2481, 2494-2497
PETROLIANA	STRYKER'S RESTORATION SERVICE	B2487-2489, 2501-2503
MISCELLANEOUS	HACK, JIM	B2504-2506, 2518-2520
CLOCKS	SUTTON, RON	B2507-2514
USED CAR PARTS	LEE, BOB	B2718-2719
USED CAR PARTS	FOOR, RICHARD	B2726-2727
MISCELLANEOUS	COCHRAN, CHUCK	B2729-2730
MISCELLANEOUS	AMERICAN KIT CAR	B2731-2735

VENDOR CATEGORY	COMPANY/ VENDOR NAME	BOOTH NUMBER
USED CAR PARTS	JONES, DIANNA	B2141-2142, 2157-2158
ANTIQUES	HAYS, EARL	CC085-086
MISCELLANEOUS	HOTRODDERS WISH LIST	CC133-159
PETROLIANA	BOEHMAN, JERRY	CC182-184
BEER ADVERTISING SIGNS	PARKER, GARY	CC205-208
MISCELLANEOUS	HAUCH, HARRY	CC229, 253
MISC. AUTOMOBILIA	HUBBARD, DALE	CC373, 397-398
MISC. AUTOMOTIVE	TURBEN, JERRY	CC374
MISCELLANEOUS	MONROE, JIM	CC421-446
MISC. AUTOMOTIVE	SPECIALTY TRUCK EQUIPMENT STRAPMAN	D7021-7023, 7045-70447
MISCELLANEOUS	VALLIE, JOHN	D7063-7064
MISCELLANEOUS	FEATHERSTONE, BARRY	D7066
MISCELLANEOUS	CHASSIS CONCEPTS	D7069-7071, 7093-7095
MISCELLANEOUS	THRAILKILL, DAVID	D7089
PETROLIANA	STAFFORD, STEVE	D7092
TOOLS	AVINA SPECIALTIES	D7116-7117, 7139
INSURANCE	HAGERTY INSURANCE	IA129, OD263
TRANSPORTERS/SHIPPERS	RELIABLE CARRIERS INC	IA130-131
MOTOR COACHES	HOLLAND MOTOR HOMES	OA151
TOOLS	MILLNER-HAUFEN TOOL CO.	OA156
BATTERIES/BOXES/CABLES	BATTERY SAVER MID-WEST	OA157
MISCELLANEOUS	CREATIVE CHARACTERS	OA158-159
TRAILERS	LOOK TRAILERS	OA160-162
TRAILERS	ED'S TRAILERS	OA163-164
NOT-FOR-PROFIT	TURNSTONE	OA193-194
FIRE EXTINGUISHER	VINTAGE FIRE EXTINGUISHERS	OA167
NOT-FOR-PROFIT	ACD MUSEUM	OA169-170
DISPLAYS & ADVERTISING	LEAF FILTER NORTH, LLC.	OA171
CAR COVERS	CONFEZIONI ANDREA NORTH AMERCIA LLC	OA180-182
MISCELLANEOUS	VINTAGE CHEVROLET CLUB OF AMERICA	OA183-184
MISCELLANEOUS	RUST AND DUST STUDIOS	OA185-186
SERVICE	FAYLOR CONSTRUCTION	OA187-188
MISCELLANEOUS	QUALITY COATINGS	OA190-192
PINSTRIPING & GRAPHICS	DECO ILLUSIONS LLC	OA200-203
JEWELRY	PERFECT 10 SALON SPA BOUTIQUE	OA204-206



VENDOR CATEGORY	COMPANY/ VENDOR NAME	BOOTH NUMBER
AUTOMOBILIA	TAC	0A211-212
REPLICA COBRA	MANSFIELD MOTOR GROUP	5011-5017
MISC. MEMORABILIA	SHIREEN	0A244
SCOOTERS RENTAL	AUToFarm MOBILITY	0A245-248
MOTOR COACHES	HOLLAND MOTOR HOMES	5001-5010
TIRES/TUBES	COKER TIRE	0D251-256
MISCELLANEOUS	OUT OF SIGHT AUDIO	0D257
MISCELLANEOUS	ROWE, JIM	0D258-259
GOLF CARTS	HOT ROD CARTS LLC	0D260-262
MISCELLANEOUS	CARCAPSULE USA INC	PA4002-4005
NEON SIGNS	VINTAGE TIN ADVERTISING	PA4006-4011
GAS STATION ITEMS	TIME PASSAGES LTD	PA4012-4015
BIKES	RECON POWER BIKES	PA4017-4019
EXHAUST	PYPES EXHAUST / COLD CASE RADIATORS	PA4020-4026
MOTORCYCLES	HARLEY DAVIDSON	0A162-163
JEWELRY	PACULA DESIGNS	0A155



CAR CORRAL

BOOK NOW
1.260.927.9797 | VENDORS@RMSOTHEBYS.COM



SWAP MEET

BOOK NOW
1.260.927.9797 | VENDORS@RMSOTHEBYS.COM



VENDORS

BOOK NOW
1.260.927.9797 | VENDORS@RMSOTHEBYS.COM



GOLF CART RENTALS

CALL TO RENT
1.859.455.9586 | DEVERINC.COM



*On Site at the Auburn Auction Park
Scooter Rentals & Sales*

Scooters can be used throughout the show, including inside tents & buildings

Reserve Your Scooter NOW!
765-354-2261

Scooter Rental Location:
West end of the Arena



Active | Comfortable | Independent!

- Mobility Vehicles
- Scooters
- Power Chairs
- Lift Chair Recliners
- Mobility Aids

AutoFarmMobility.com



PYPES

PERFORMANCE EXHAUST



SPACES
P4020-4026

- SYSTEMS
- COLLECTORS
- X-PIPES
- CUTOUTS
- TIPS
- ACCESSORIES

*Stay in touch with the best
antiques auctions.*

Call today to receive a
1-year subscription (51 issues)
of the nation's leading antiques,
auction and show newspaper!

Only \$24.95

(NEW SUBSCRIBERS ONLY)

AntiqueWeek

800.876.5133

www.antiqueweek.com



Premium Craftsmanship, Exceptional Style



Tailor-Made To Fit Every Vehicle

For over 45 years, Confezioni Andrea covers have been protecting high-end and classic vehicles throughout Europe, from Bugatti to Maserati. We now bring our legendary Class Indoor Covers and Future Outdoor Covers to the US. We hand measure all vehicle models so that each cover fits like a well-tailored Italian suit — light, structured and cut to follow the vehicle's exact contour. Why not enjoy the spoils and protect your car from the elements?



CONFEZIONI ANDREA NORTH AMERICA LLC
Precision Tailored Vehicle Protection

(888) 542-2051 | sales@confezioniandrea.us | confezioniandrea.us | 



Enjoy your Vintage car with us!

See the country and make new friends while you drive your historic vehicle

www.vmcca.org

(816) 298-6412



The Touring Club



Out of Sight Audio

4 Models Available

Dont Cut That Dash!

No radio? - Hide an Out Of Sight Audio device and run your audio system from your cell phone.

Working radio? - Integrate Bluetooth audio signal into almost any existing stereo system.

Nonworking radio? - Remote mount an Out Of Sight Audio device and enjoy Bluetooth music.



No radio required for operation

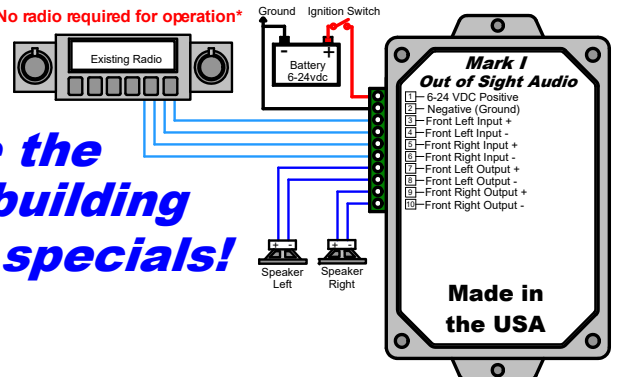

See us outside the Duesenberg building for auction specials!

- * 6 - 24 Vdc operation
- * No radio needed for operation
- * 75 Watt amplification included
- * Simple & nonintrusive installation
- * Can be used on positive earth systems
- * Compact design (5-5/8" x 3-7/8" x 1-1/4") 12 Oz
- * Control with any smartphone with bluetooth capabilities

Made in the USA

outofsightaudio.com

Hemmings Motor News

Brings you 3 great car publications to choose from



**The World's
Largest
Collector-Car
Marketplace!**

**12 ISSUES
ONLY \$31.95!**
(that's only \$2.66 an issue)



**The Definitive
All-American
Collector-Car
Magazine!**

**12 ISSUES
ONLY \$18.95!**
(that's only \$1.58 an issue)



**The Ultimate
All-American
Performance Car
Magazine!**

**12 ISSUES
ONLY \$18.95!**
(that's only \$1.58 an issue)



Get Your RISK-FREE Issue Today!

Call 800-227-4373, ext. 79550 now!

If I like it, I'll pay the invoice for the amount shown above for 11 more issues (12 issues in all).
If I decide the Hemmings magazine I've ordered is not for me, I'll write "cancel" on the invoice,
return it within 10 days and pay nothing at all. Either way, the first issue will be mine to keep!

You can find out more and order on our website: www.hemmings.com/subscribe

See us across from the food court at the auction entrance

ATTENTION CHEVROLET & GMC FANS!

Every collector car owner needs a club...we invite you to join ours.



- Membership as Low as \$25/yr
- Award-Winning Monthly Magazine
- Local Regions & Chapters
- Nationally Judged Meets
- Technical Advice
- Driving Tours

Vintage Chevrolet Club of America • vcca.org • 708.455.8222

WATCHES • ART • BADGES • BANNERS • AUTO BOOKS • CLOCKS • CLOTHING • COIN BANKS • DECALS • DECANTERS • DIECAST • FLAGS • GAS CANS • GAS NOZZLES • GAS GLOBES • GAS PUMPS • HOOD ORNAMENTS • JEWELRY • KEY

Great News for Automobilia Collectors & Enthusiasts!

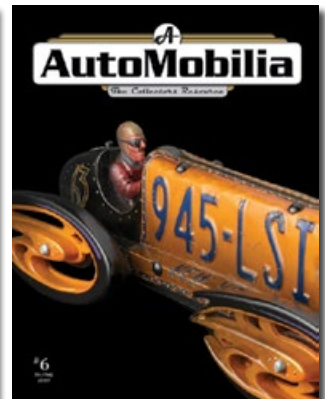
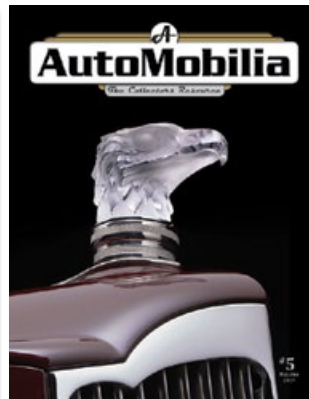

Automobilia enthusiasts, collectors, and industry professionals finally have their own magazine and website dedicated to automotive memorabilia!



Regular columns written by well-known industry professionals discuss trends, values, prices and the sheer joy of collecting.
6 issues \$36 • Subscribe at: AutoMobiliaResource.com • Subs@AutoMobiliaResource.com • 954-579-5280

OWNERS MANUALS • PAPER WEIGHTS • PATCHES • PEDAL CARS • PENS • PENNANTS • PIN-UPS • PETROLIANA • PHOTOGRAPHS • PORCELAIN SIGNS • POSTERS • RACING MEMORABILIA • RADIOS • SCULPTURE • SHIFTER KNOBS

SIGNS • SPARK PLUGS • SPECIALTY FURNITURE • STEERING WHEELS • STORE DISPLAYS • THERMOMETERS • TOOL KITS • TOYS • TROPHIES

KEY CHAINS • KIT MODELS • LICENSE PLATES • LIGHTS • LITERATURE • MAGAZINES • MARSCOTS • MODEL CARS • NEON SIGNS • OIL CANS



*In with the old.
Out with the new.*



OmniSource
The Best in Metals Recycling



Steel Dynamics, Inc.®



HARLEY-DAVIDSON OF FORT WAYNE
 6315 ILLINOIS ROAD | FORT WAYNE, IN 46804
 (260)489-2464 | HARLEYDAVIDSONFORTWAYNE.COM

Free Saddle Bag Essential
with \$35 Purchase



*Regular priced General Merchandise only.
Valid through 9/31/19

Free HDFW T-Shirt
with \$100 purchase



*Regular priced General Merchandise only.
Valid through 9/31/19





Lot 3125: 1971 Ferrari 365 GTB/4 Daytona



Featuring
The
Jim Mangione
Collection



Auctions

rmsothebys.com

Collectors gather here.